

## Research Article

**Cite this article:** Wendt EW, Malabarba LR, Braga MP, Boeger WA, Landis M, Carvalho TP (2022). Phylogeny, species delimitation and ecological and morphological diversity of *Characithecium* (Monogenoidea: Dactylogyridae). *Parasitology* **149**, 700–716. <https://doi.org/10.1017/S0031182022000221>

Received: 9 July 2021

Revised: 18 February 2022

Accepted: 23 February 2022

First published online: 3 March 2022

**Key words:**



Divergence time estimates; host–parasite associations; molecular phylogeny; morphological; taxonomy

**Author for correspondence:**

Emília W. Wendt,

E-mail: [wendtemi@gmail.com](mailto:wendtemi@gmail.com)

# Phylogeny, species delimitation and ecological and morphological diversity of *Characithecium* (Monogenoidea: Dactylogyridae)

Emília W. Wendt<sup>1</sup> , Luiz R. Malabarba<sup>1</sup>, Mariana P. Braga<sup>2</sup> , Walter A. Boeger<sup>3</sup>, Michael Landis<sup>2</sup> and Tiago P. Carvalho<sup>1,4</sup>

<sup>1</sup>Laboratório de Ictiologia, Departamento de Zoologia, Universidade Federal do Rio Grande do Sul – UFRGS, Av. Bento Gonçalves, 9500, Bloco 4, prédio 43435, 91501-970 Porto Alegre, RS, Brazil; <sup>2</sup>Department of Biology, Washington University in St. Louis, St. Louis, MO 63130, USA; <sup>3</sup>Biological Interactions and Departamento de Zoologia, Centro Politécnico, Setor de Ciências Biológicas, Universidade Federal do Paraná (UFPR), Caixa Postal 19073, CEP 81531-980, Curitiba, Paraná, Brazil and <sup>4</sup>Laboratorio de Ictiología, Unidad de Ecología y Sistemática (UNESIS), Departamento de Biología, Facultad de Ciencias, Pontificia Universidad Javeriana, Carrera 7 No. 43-82, Bogotá D.C., Colombia

**Abstract**

*Characithecium* (Monogenoidea, Dactylogyridae) is a genus containing nine species that live on the gills of a characid clade containing genera *Astyanax*, *Andromakhe*, *Psalidodon* and *Oligosarcus* (Characiformes, Characidae) in South and Central America. Earlier studies suggest a tight coevolutionary history between these parasites and their hosts mainly due to the phylogenetic proximity between these genera of fish. Hence, this study explores phylogenetic relationships, species limits and extrinsic factors (geography and ecology) explaining parasite prevalence. To understand the evolutionary history of the genus, we constructed a time-calibrated phylogenetic hypothesis, which includes eight of the nine known species of *Characithecium* sampled from a broad spectrum of host species. The phylogeny supports the monophyly of *Characithecium*, with its most recent common ancestor dating from the Miocene. Using generalized mixed-yule coalescent and Bayesian Poisson tree process methods, species delimitation analyses suggested fewer species than the proposed delimitation based on morphology alone, recovering four and six entities, respectively. The results indicate that species of *Characithecium* have wider geographical and host distribution and higher prevalence on *Oligosarcus* species compared to *Astyanax* and *Psalidodon*. Correlation between parasite prevalence and biotic and abiotic traits, based on generalized linear models, indicates that the frequency of occurrence of different species of *Characithecium* is associated with distinct factors, such as host genus, high altitudes, rivers and streams, and different ecoregions. Our results suggest that species of *Characithecium* are highly opportunistic, exploring resources in different manner as our data reveal the ability of these parasites to explore a diverse environment of variable biotic (e.g. hosts) and abiotic features.

**Introduction**

Monogenoidea Bychowsky, 1937 is a group of obligate parasites commonly found in freshwater and marine fishes (Boeger and Vianna, 2006; Cohen *et al.*, 2013). Species from this class of Platyhelminthes are often used as a model system in studies that investigate host–parasite coevolution (Domingues and Boeger, 2005; Mendlová and Šimková, 2014; Braga *et al.*, 2015; da Graça *et al.*, 2018). Historical host–parasite associations between Monogenoidea and freshwater Neotropical fishes are fascinating due to the host's geographic isolation in hydrographic basins, which have complex biogeographical histories (Albert *et al.*, 2020), and the phylogenetic conservatism of host repertoires among the parasites (Braga *et al.*, 2015).

*Characithecium* Mendoza-Franco, Reina & Torchin, 2009 (Dactylogyridae) is a genus of Monogenoidea with nine described species parasitizing the gills of freshwater fishes in Central (Mexico and Panama) and South America (Colombia, Brazil and Argentina). So far, species of *Characithecium* are known to occur on a few species of *Astyanax* [*Astyanax aeneus* (Günther, 1860), *Astyanax ruberrimus* Eigenmann, 1913 [synonym of *Astyanax panamensis* (Günther, 1864)], *Astyanax lacustris* (Lütken, 1875), *Astyanax scabripinnis* (Jenyns, 1842) and *Astyanax bimaculatus* (Linnaeus, 1758)], and on *Psalidodon fasciatus* (Cuvier, 1819) and *Oligosarcus jenynsii* (Günther, 1864) (Kritsky and Leiby, 1972; Gioia *et al.*, 1988; Boeger and Vianna, 2006; Rossin and Timi, 2015; Gallas *et al.*, 2016).

*Characithecium* remained monotypic until Rossin and Timi (2015) proposed a diagnostic amendment for the genus and a new species combination to accommodate *Palombitrema chascomusensis* Suriano, 1981 (= *Characithecium chascomusensis*). These authors also described four new species from the gills of *O. jenynsii* collected in the Chascomús lake and Nahuel Rucá lake, in the province of Buenos Aires (Argentina). Later, Gallas *et al.* (2016) described *Characithecium triprolatum* Gallas, Calegari-Marques & Amato, 2016, from the gills of *Psalidodon* aff. *fasciatus* and *Astyanax jacuhiensis* Cope, 1894 (=junior

synonym of *A. lacustris*) from the Guaíba lake, in Rio Grande do Sul State (Brazil). Recently, new studies have described two new species of *Characithecium* occurring on the gills of *Astyanax* and *Psalidodon* species in Brazil. Da Silva *et al.* (2021) described *Characithecium bifurcuprolatum* da Silva, da Silva & Yamada, 2021, and reported the occurrence of *Characithecium costaricensis*, both species found on the gills of *A. bimaculatus* in Northeast Brazil, and Zago *et al.* (2021) described *Characithecium paranapanemense* Zago, Franceschini, Abdallah, Müller & Azevedo, 2021 parasitizing the gills of *Psalidodon paranae* (Eigenmann, 1914) and *Psalidodon bockmanni* (Vari and Castro, 2007) collected in streams of the Middle Paranapanema river. This last article carried out morphological and molecular analyses to characterize the described species. In a molecular phylogeny using 28S rDNA, species of Dactylogyridae were included, as well as some samples of *C. paranapanemense* and *C. costaricensis*, where these two latter species were recovered as sister species in a clade closely related to species of *Urocleidoides*. However, a more comprehensive phylogeny for *Characithecium*, built to study the evolutionary history of the clade, is still needed.

The occurrence of *Characithecium* in phylogenetically close hosts led Rossin and Timi (2015) to highlight the possibility of coevolution between the species of parasites and their hosts. Recent studies recovered (*Astyanax* (*Andromakhe* (*Oligosarcus* + *Psalidodon*))) composing the Gymnocharacini tribe within Stethaproninae, a species-rich subfamily within Characidae (Mirande, 2020; Terán *et al.*, 2020). *Oligosarcus* is monophyletic, composed of 22 species, and distributed in river basins in southeastern South America (Ribeiro and Menezes, 2015; Wendt *et al.*, 2019). On the contrary, *Astyanax* has long been recognized as a polyphyletic genus in Characidae, with some of its species having been recently transferred to the genera *Psalidodon* and *Andromakhe* to represent monophyletic genera (see Mirande, 2020; Terán *et al.*, 2020). Wendt *et al.* (2019) recently studied the phylogenetic relationships, divergence times and biogeography of *Oligosarcus* species, including an extensive outgroup formed by several species currently referred to *Astyanax* and *Psalidodon*. According to this reconstruction, the most recent common ancestor of *Oligosarcus* inhabited drainages in the Brazilian crystalline shield (which included the Upper Paraná river basin and coastal region drainages of Brazil) in the Pliocene (~5 Ma), and the biogeographical history of this genus was influenced by sea-level changes during the Pleistocene and the formation of barriers (waterfalls) in the Paraná river basin (Wendt *et al.*, 2019).

The complex evolutionary history of *Oligosarcus* directly reflects the changes in drainage configurations that occurred in the southeastern region of South America (Ribeiro, 2006; Wendt *et al.*, 2019). Vicariant events were likely responsible for the current allopatric distribution of most lineages of *Oligosarcus*, and subsequent dispersion events resulted in secondary contact and sympatry in some groups of the genus (Wendt *et al.*, 2019). These events of separation and connection of lineages within *Oligosarcus* may have influenced the diversity and evolutionary history of the parasites occurring in these fishes. Furthermore, species of the clade containing *Oligosarcus*, *Astyanax*, *Andromakhe* and *Psalidodon* have relatively broad ecological requirements in freshwaters (Costa-Pereira *et al.*, 2016; Wendt *et al.*, 2019), with species variably occurring in distinct habitats (e.g. rivers, streams and lakes) and in distinct portions of drainages (e.g. headwaters and lowlands).

A wide range of evolutionary characteristics observed in these fishes and the complex host–parasite relationship make *Characithecium* and its host's excellent models for coevolutionary studies. Furthermore, a detailed study on the geographic distribution of *Characithecium* and the occurrence of these parasites in

different hosts can be analysed following the assumptions of the Stockholm paradigm (Hoberg and Brooks, 2015). The Stockholm paradigm is a theoretical concept that uses several ecological processes, such as ecological fitting, oscillation and taxon pulse, to explain how the host–parasite relationship evolves, where new hosts (=resources) can be added or lost over evolutionary time. Thus, this new concept resolved the parasite paradox (Agosta *et al.*, 2010) since specialist parasites are widely found in nature even so, several phylogenetic and coevolutionary studies demonstrate high levels of host switching. After the proposal of the Stockholm paradigm, it was possible to understand better that parasites can promptly colonize new hosts when given an opportunity. Therefore, the broad ecologies and geographic distributions of the species of *Oligosarcus*, *Astyanax*, *Andromakhe* and *Psalidodon* may provide opportunities for parasites, including *Characithecium*, to colonize new hosts (Araujo *et al.*, 2015; Hoberg and Brooks, 2015; Brooks *et al.*, 2019; Agosta and Brooks, 2020).

Hence, this study evaluates the evolutionary history and diversification of species of *Characithecium*. Phylogenetic relationships and species limits were evaluated based on molecular data, species distribution (both in geographical space and among hosts) and was tested if parasite prevalence could be predicted by ecological characteristics.

## Materials and methods

### Parasite sampling

The host sampling consisted mainly of numerous specimens from scientific collections which had already been collected previously. In addition, when necessary, new collections were carried out to cover sampling gaps. Therefore, the samples come from 2009 to 2019 and refer to different seasons of the year. Parasites collected from fish specimens were fixed and preserved in 96% alcohol for molecular analyses, and parasites found in specimens fixed in formalin 10% and preserved in 70% alcohol were used for morphological identification and to assemble permanent slides. Host specimens deposited in the following ichthyological collections were examined: Coleção de Peixes do Departamento de Zoologia e Botânica da Universidade Estadual Paulista, São José do Rio Preto (DZSJRP); Laboratório de Biologia e Genética de Peixes da Universidade Estadual Paulista, Botucatu (LBP); Museu de Ciências e Tecnologia da Pontifícia Universidade Católica do Rio Grande do Sul, Porto Alegre (MCP); Museu de Zoologia da Universidade Estadual de Londrina, Londrina (MZUEL); Coleção de Peixes do Departamento de Zoologia da Universidade Federal do Rio Grande do Sul, Porto Alegre (UFRGS) and Coleção Zoológica da Universidade Federal do Mato Grosso do Sul, Campo Grande (ZUFMS). Additional host specimens have recently been collected in field expeditions to fill gaps in host–species representation and their geographic distribution. These specimens were euthanized in a solution containing Eugenol (following Lucena *et al.*, 2013) and then fixed and preserved in 96% alcohol. Collection permits were given by Instituto Chico Mendes de Conservação da Biodiversidade (ICMBio) to LRM (SISBIO No. 12038-1). Applicable institutional guidelines for the care and use of animals were followed and approved by the Ethics Committee of the Universidade Federal do Rio Grande do Sul (Porto Alegre, Brazil; CEUA-32283).

For evaluation of host–parasite relationships, we examined 351 specimens of fishes representing 17 species of *Oligosarcus* and 124 specimens representing nine species of *Astyanax* and six of *Psalidodon* from different geographic regions. *Astyanax* and *Psalidodon* belong to clades that are closely related and often sympatric to *Oligosarcus* species (Wendt *et al.*, 2019). For parasite

removal, the gills were intensively washed with 96% alcohol bursts using a syringe, and whenever possible, gill arches were carefully dissected and analysed. Then, parasite specimens were stored in vials containing 96% alcohol and kept in a freezer at  $-4^{\circ}\text{C}$ . Part of these parasite specimens (fixed in formalin 10%) was mounted on permanent slides using Hoyer, and identified to the species level, using an Olympus BX51 microscope, following morphological characteristics given by Mendoza-Franco *et al.* (2009), Rossin and Timi (2015) and Gallas *et al.* (2016). In addition to using the original descriptions, all the material was carefully compared with the voucher specimens of *C. triprolatum* (deposited in the helminthological collection of UFRGS) and from photos of the holotypes of the species *C. chascomusensis*, *Characithecium chelatum*, *Characithecium longianchoratum*, *Characithecium robustum* and *Characithecium quadratum* provided by Dr Lia Lunaschi, curator of the helminthological collection at Colecc de Invertebrados del Museo de La Plata, FCNyM-UNLP. *Characithecium* species were determined based on diagnostic characters such as the size and shape of the sclerotized parts of the attachment organ (haptor) and the reproductive organs (male copulatory complex and vaginal opening). Other parasite specimens (fixed in 96% alcohol) were used in molecular analysis, so they were mounted on a temporary glass slide containing glycerin and identified to the species level. Then, a permanent slide was designated as a paragenophore, to represent the sample used in molecular analyses. The paragenophores were mounted in Hoyer mounting medium (Humason, 1979) and deposited in the helminthological collection of the Instituto Oswaldo Cruz, Rio de Janeiro, Brazil (CHIOC) and helminthological collection of the Instituto de Biociências da Universidade Federal do Rio Grande do Sul (UFRGS; Table S1).

#### DNA extraction, polymerase chain reaction (PCR) and sequencing

Most of the examined samples were from museum-preserved material, which allowed us to have extensive sampling, but required specific activities during molecular processing to avoid DNA loss. *Characithecium* specimens were removed and sequenced from *Oligosarcus* and *Astyanax* hosts given that the examined *Psalidodon* specimens were fixed only in formalin, making it difficult for DNA extraction. DNA was extracted from individual parasites ( $n=35$ ) according to the simplified method described by Tkach and Pawlowski (1999), which was designed to result in minimal DNA loss. The DNA of seven of the nine species described for *Characithecium* was extracted and amplified: *C. costaricensis*, *C. chascomusensis*, *C. chelatum*, *C. longianchoratum*, *C. quadratum*, *C. robustum* and *C. triprolatum*.

Furthermore, regarding the two species recently described for *Characithecium*, only *C. paranapanemense* has sequences of 28S rDNA deposited in GenBank and these sequences were properly included in the phylogenetic analysis (GenBank accession numbers: MZ408907, MZ408902 and MZ408908). Two ribosomal nuclear genes were amplified, 28S rDNA and 18S rDNA. The primers C1 (5' ACCCGCTGAATT TAAGCAT 3') and C3 (5' CTCTTCAGAGTACTTTTCAAC 3') were used to amplify a fragment of approximately 400 bp of 28S rDNA (Mollaret *et al.*, 2000). After several efforts to amplify the 18S rDNA using primers available in the literature (e.g. Littlewood and Olson, 2001), we were not successful. Therefore, a new primer was designed to amplify the 18S rDNA region. These new primers – 18S rDNA: 188F (5' TGACGTTGGATGTCAGACGG 3') and 18S rDNA: 486R (5' TAGTTTGTC TGGCGACGGTC 3') – were used to amplify a fragment of approximately 478 bp of 18S rDNA. These primers were developed based on a sequence of the Dactylogyridae *Diaphorocleidus armillatus* Jogunoori,

Kritsky, and Venkatanarasaiah, 2004 (GenBank accession number: KT597997.1). Primer3Plus software (Untergasser *et al.*, 2007) was used, and the quality of the primer was tested in software NetPrimer (<http://www.premierbiosoft.com/netprimer/netprlaunch/netprlaunch.html>).

The PCR programme for 28S rDNA was as follows: 5 min at  $95^{\circ}\text{C}$ , followed by 40 cycles of 1 min at  $94^{\circ}\text{C}$ , 1 min at  $45^{\circ}\text{C}$ , 2 min at  $72^{\circ}\text{C}$  and completed with 7 min at  $72^{\circ}\text{C}$ . The PCR programme for 18S rDNA was as follows: 5 min at  $95^{\circ}\text{C}$ , followed by 40 cycles of 1 min at  $95^{\circ}\text{C}$ , 45 s at  $50^{\circ}\text{C}$ , 1 min at  $72^{\circ}\text{C}$  and finally 5 min at  $72^{\circ}\text{C}$ . Each amplification reaction contained 3–5  $\mu\text{L}$  template DNA, 3 mM  $\text{MgCl}_2$ , 1 $\times$  PCR buffer (Invitrogen, Massachusetts, USA), 0.5 pmol each primer, 0.4 mM dNTP and 1 U platinum Taq polymerase (Invitrogen) in a total volume of 25  $\mu\text{L}$ . PCR products were checked by electrophoresis in agarose gel, purified using ExoSap (Exonuclease I and Shrimp Alkaline Phosphatase GE Healthcare<sup>®</sup>, Piscataway, NJ, USA) and sequenced in both directions by ACTGene (Porto Alegre, Brazil). Forward and reverse sequences were visually inspected, edited using software Geneious 8.0 (Kearse *et al.*, 2012) and aligned using default parameters of the algorithm MAFFT (Katoh *et al.*, 2002), available on the GUIDANCE server (<http://guidance.tau.ac.il/>; Penn *et al.*, 2010), that guides the removal of parts of the alignment that showed low reliability. The sequences of 28S rDNA and 18S rDNA of *Characithecium* species were deposited in GenBank (Table S1). The pairwise genetic distances were calculated in Geneious 8.0 (Kearse *et al.*, 2012) using the Tamura–Nei model (Tamura and Nei, 1993; Table S2).

#### Phylogenetic reconstruction and divergence time estimation

Bayesian inference was performed using BEAST2 v2.5.1 (Bouckaert *et al.*, 2014) to estimate phylogenetic relationships of the gene tree for 28S rDNA (the most densely sampled marker). Nucleotide substitution models for 28S rDNA and 18S rDNA genes were evaluated using PartitionFinder v1.1.1 (Lanfear *et al.*, 2012). For the gene tree analysis of the 28S rDNA, the birth–death model was set as a tree prior, and the relaxed log-normal clock was used as the clock model. The analysis ran for 10 000 000 generations, sampling every 1000 generations and species of Dactylogyridae selected from GenBank were used as outgroup (Table S1).

Using this single gene (28S rDNA) dataset, a molecular time divergence analysis was conducted in BEAST v2.5.1 (Bouckaert *et al.*, 2014). For that, we used the evolutionary rate of the 28S rDNA proposed to Proseriata (Platyhelminthes; Scarpa *et al.*, 2015). A relaxed lognormal clock model was set, with an evolutionary rate of 0.005 mutations per million years for the 28S rDNA. The birth–death model was used as a tree prior (Nee *et al.*, 1994).

Species Tree analysis using both markers (28S rDNA and 18S rDNA) was conducted. Specimens of *Jainus* and *Cacatuocotyle* were included as outgroups. The birth–death model was set as the tree prior, and the relaxed clock was configured as the clock model. The analysis was conducted with two runs of four chains conducted simultaneously for 5 000 000 generations with a sample frequency of 500 generations. The StarBEAST 2.5 template (Heled and Drummond, 2010) was used and the relaxed clock and birth–death tree models were linked to 28S rDNA and 18S rDNA datasets. The Species Tree analysis was conducted with two different approaches. First, an analysis without prior calibrations for date estimates on internal nodes. Then, an analysis using prior calibration dates on nodes based on divergence time estimations from the 28S rDNA dataset (see divergence time estimate analysis above). For that, three nodes that were congruent with the gene tree analysis (28S rDNA) were dated using minimum



age with standard deviation and using normal priors in order to calibrate the respective nodes as follows: (1) *Characithecium* node ( $12.20 \pm 2.6$  Ma of standard deviation), (2) the node formed by *C. triprolatum*, *C. quadratum* and *C. paranapanemense* ( $1.46 \pm 0.6$  Ma standard deviation) and (3) the node formed by *C. costaricensis* (*C. longianchoratum* (*C. chelatum* (*C. chascomusensis* + *C. robustum*))) ( $6.08 \pm 1.8$  Ma standard deviation). The minimum age and standard deviation were obtained from the 28S rDNA tree dated from the evolutionary rate of this marker.

Morphological diagnostic traits of each species (Mendoza-Franco *et al.*, 2009; Rossin and Timi, 2015; Gallas *et al.*, 2016) were the criteria for grouping specimens into putative species in the Species Tree analysis. The analysis ran for 15 000 000 generations with a sample frequency of 1500 generations. All these analyses were implemented with XSEDE (3.2.6) in the CIPRES portal (Miller *et al.*, 2010).

For all the Bayesian analyses mentioned above, we inspected stationary posterior probabilities using Tracer v1.6 (Rambaut *et al.*, 2014) and checked for effective sample size's above 200. The first 10% of the trees were discarded as burn-in, and the remaining trees were summarized using the maximum clade credibility tree function in TreeAnnotator 2.4.3 (Bouckaert *et al.*, 2014).

### Species delimitation

Species-delimitation analyses were carried out and contrasted with the current proposed morphological delimitations, using variable characteristics within *Characithecium*, which distinguish one species from another (summarized in Table S3). We observed the morphology (shape of the sclerotized pieces) from the collected specimens (our examined material) and compared them with the literature information (Mendoza-Franco *et al.*, 2009; Rossin and Timi, 2015; Gallas *et al.*, 2016). Species-delimitation analyses using a single locus were carried out with the generalized mixed-yule coalescent (GMYC) method (Pons *et al.*, 2006; Fujisawa and Barraclough, 2013) and the Bayesian implementation of the Poisson tree processes (bPTP) method (Zhang *et al.*, 2013). According to Zhang *et al.* (2013), these two methods of species delimitation differ in that GMYC uses branch lengths (timed divergences) to identify when divergence times more closely resemble coalescence events rather than speciation events, while bPTP uses the number of substitutions. As the input tree for the GMYC, we used the summarized ultrametric tree that was reconstructed using the 28S rDNA gene in BEAST2 v.2.5.1. The GMYC analysis was carried out in the R package 'Splits' (Ezard *et al.*, 2009) with a single threshold. The bPTP analysis was carried out on the online server (<https://species.h-its.org/>) using the unrooted tree, following the default parameters (with 100 000 generations), and using the summarized (not ultrametric) 28S rDNA tree reconstructed using MrBayes 3.2.2 (Ronquist *et al.*, 2012). For this tree, we set K80 + G as the nucleotide substitution model (as proposed by PartitionFinder) and conducted two simultaneous runs of four chains over 10 000 000 generations, sampling every 1000 generations.

### Occurrence and ecological traits of *Characithecium*

After the collection and subsequent species determination of parasites, we characterized each species of *Characithecium* based on: (1) host genus; (2) host species; (3) prevalence in each host species, i.e. the percentage of examined host specimens that contained the focal parasite species (Bush *et al.*, 1997); (4) parasite geographic distribution, which includes country, state, river basin, freshwater ecoregion and if it belongs to coastal and/or continental basins; (5) altitude of occurrence (in metres) and (6) categorical habitat type (river, stream, lake or a combination of those).

**Table 1.** Models created with ecological variables used to explain parasite prevalence from GLM analysis

| Model | Variables included                               | Number of variables |
|-------|--|---------------------|
| M0    | Null model                                       | –                   |
| M1    | Host + altitude class + habitat type + ecoregion | 4                   |
| M2    | Host + altitude class + habitat type             | 3                   |
| M3    | Host + altitude class                            | 2                   |
| M4    | Host   | 1                   |
| M5    | Host + habitat type                              | 2                   |
| M6    | Host + ecoregion                                 | 2                   |
| M7    | Altitude class + habitat type + ecoregion        | 3                   |
| M8    | Altitude class + habitat type                    | 2                   |
| M9    | Altitude class + ecoregion                       | 2                   |
| M10   | Habitat type + ecoregion                         | 2                   |
| M11   | Altitude class                                   | 1                   |
| M12   | Habitat type                                     | 1                   |
| M13   | Ecoregion  | 1                   |

It was tested whether some biotic and abiotic variables explain the prevalence of each species of *Characithecium*. Generalized linear models (GLMs) were used for this analysis, using the binomial distribution (recommended for data with proportions, such as prevalence). In total, 13 models were created (M1–M13) with interactions between one or more of the following four variables: (1) geographic distribution – ecoregion, (2) habitat type, (3) altitude class and (4) host genus – as a proxy for host phylogeny (Table 1; Fig. 1). For the GLM analysis, the altitude values were divided into four classes that were discretized based on gaps in the observed altitude values among hosts and parasites, generating the following altitude classes: class 1 = 0–100 m, class 2 = 101–400 m, class 3 = 401–800 m, class 4 = more than 801 m. We followed the Freshwater Ecoregions of the World (FEOW) proposed by Abell *et al.* (2008) for ecoregion delimitation. In addition, we tested the null model (M0), where the prevalence of the parasite species was not associated with any of the above variables. We used Akaike's information criterion (AICc) to select the model (s) that best explained the observed patterns, where models with  $\Delta AICc \leq 2$  were considered to perform equally well (Burnham and Anderson, 2002). Finally, we applied analysis of variance (ANOVA) with error type III (ideal for unbalanced data) to test the significance for each best model selected, using an  $\alpha$ -value of 0.05.

## Results

### Phylogenetic relationships, divergence time estimates and species delimitations

The fragment of the 28S rDNA (~400 bp) was composed of 38 individuals of *Characithecium*, while for 18S rDNA, which corresponded to the longest region (~478 bp), was successfully amplified for only nine individuals, representing four species of *Characithecium*. The K80 + G model was selected as the best substitution model for the 28S rDNA, while the TrNef model was selected for the 18S rDNA. The 28S rDNA fragment presented greater genetic variation compared to 18S rDNA, with 141 and 25 mutations and 92 parsimony informative sites contrasting

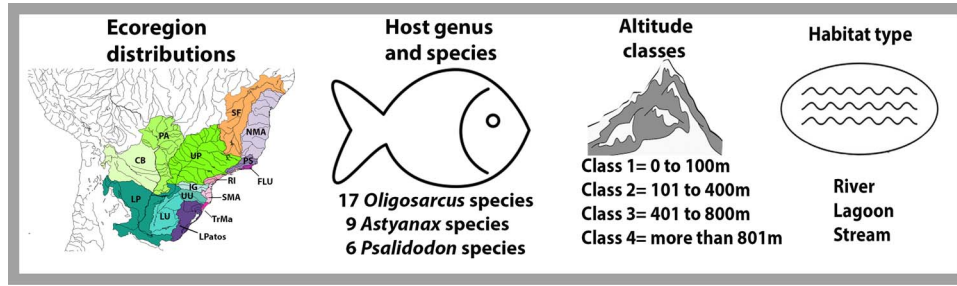

**Fig. 1.** Schematic representation of variables used to explain parasite prevalence from GLM analysis, with competing models explaining the parasite species prevalence. Map locating the ecoregions, which correspond to the study area in southeastern South America. Ecoregion abbreviations: LPatos, Laguna dos Patos; TrMa, Tramandaí-Mampituba; SMA, southeastern Mata Atlântica; RI, Ribeira de Iguape; FLU, Fluminense; PS, Paraíba do Sul; NMA, northeastern Mata Atlântica; SF, São Francisco; UP, Upper Paraná; LP, Lower Paraná; IG, Iguçu; PA, Paraguay; CB, Chaco; UU, Upper Uruguay; LU, Lower Uruguay.

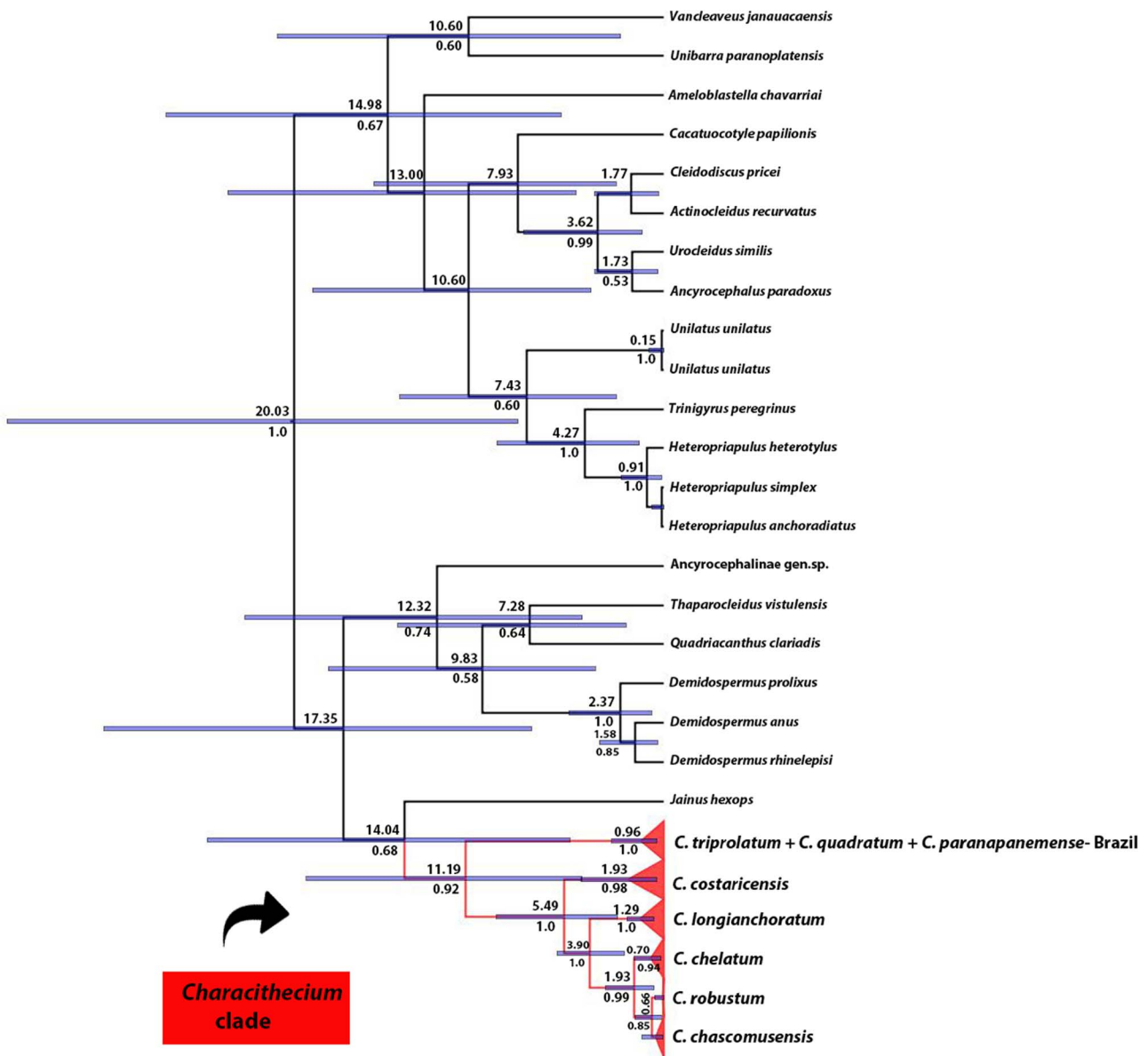
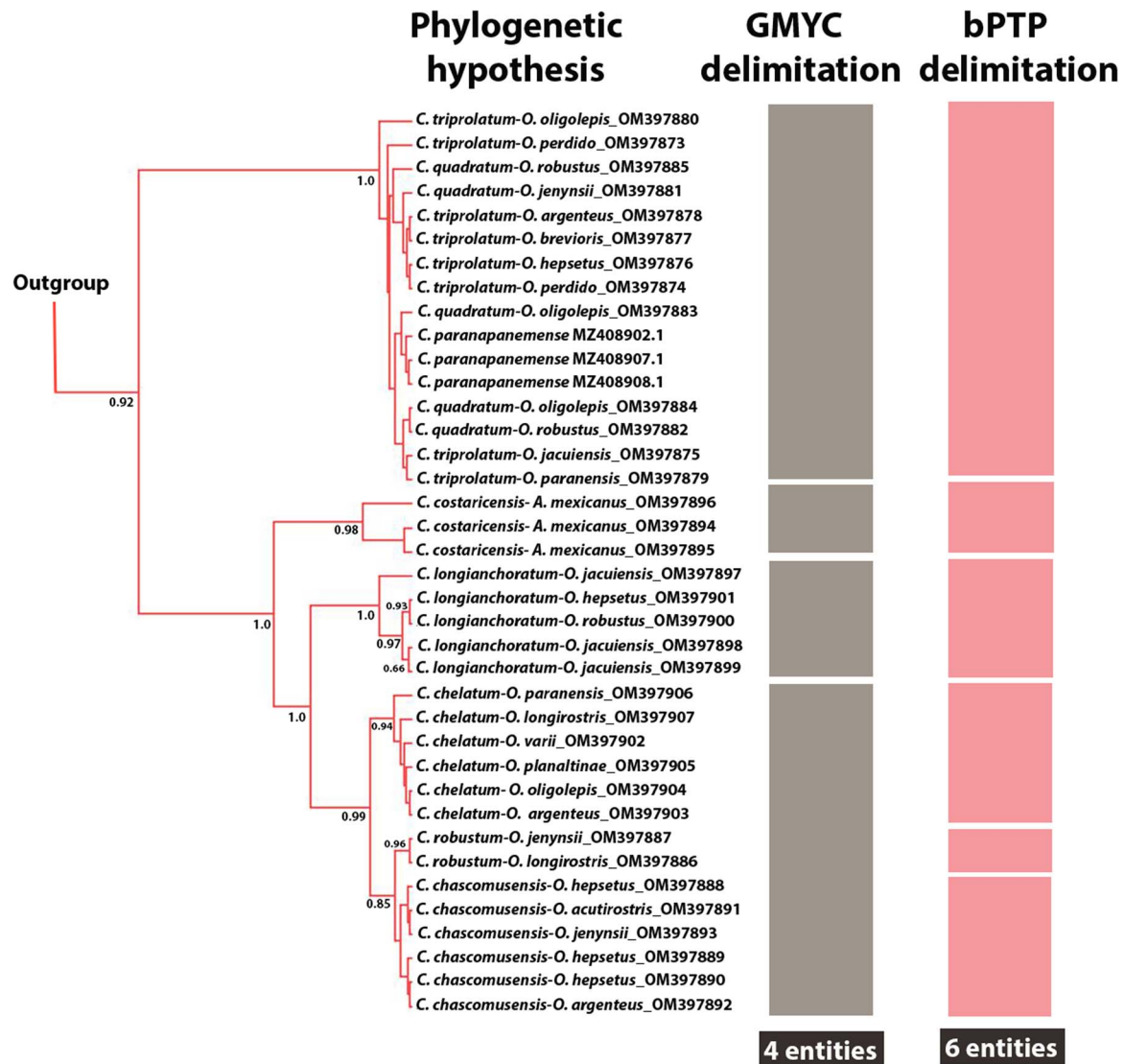

**Fig. 2.** Calibrated ultrametric hypothesis for species of *Characithecium*, together with other Dactylogyridae species, based on Bayesian inference to 28S rDNA fragment. Time estimation (median age in Ma) is represented by values above branches and posterior probabilities above 0.5 are shown below branches.

with only 19 in the 18S rDNA. The mean genetic distance (*P*-distance) between the sequences of 28S rDNA was 0.101 contrasting with 0.024 in the 18S rDNA and base frequency was *A* = 27.9%, *C* = 20.3%, *G* = 28.6%, *T* = 23.2% and for 28S rDNA *A* = 22.9%, *C* = 20.4%, *G* = 29.0% and *T* = 27.7%. Overall, intraspecific

uncorrected *P*-distances ranged from 0 to 1.15%, while the interspecific distances ranged from 0.31 to 14.12% (Table S2).

The phylogenetic reconstruction based on the 28S rDNA recovered *Characithecium* as monophyletic with high node support (PP = 0.92; Fig. 2). Given the available data, *Characithecium* was



**Fig. 3.** Phylogenetic hypothesis for *Characithecium* species based on 28S rDNA (left phylogram). Species delimitations on the right using the GMYC model and the bPTP model. Terminals in the *Characithecium* phylogeny include the name of the species of *Characithecium* and the name of the host in which the parasite individual was found. Posterior probabilities above 0.5 are shown below branches.

estimated to be a sister group to *Jainus hexops*, and these two genera are a sister group to a large clade of Dactylogyridae (Fig. 2). Within *Characithecium*, specimens were grouped in reciprocally monophyletic groups that supported the morphologically determined species relationships (Fig. 3), except for three species (*C. triprolatum*, *C. quadratum* and *C. paranapanemense*). Individuals from these three species share a most recent common ancestor (with high support), but samples show no reciprocal monophyly. We recovered a larger clade with the remaining five species of the genus with high support (PP = 1.0), being composed of *C. costaricensis* + (*C. longianchoratum* + (*C. chelatum* + (*C. robustum* + *C. chascomusensis*))). The Species Tree analysis revealed a similar topology of the gene tree analysis (28S rDNA), with high support values for most clades. The Species Tree analysis revealed *C. paranapanemense* as a sister species of the clade composed of *C. triprolatum* and *C. quadratum* (PP = 1.0; Fig. 4).

The non-monophyly of *C. paranapanemense*, *C. triprolatum* and *C. quadratum*, observed in the molecular analysis, is inconsistent with the morphological data (Table S3). *Characithecium triprolatum* and *C. quadratum* differ in several ways, such as posteromedial projection in ventral bar (present in *C. triprolatum* vs absent in *C. quadratum*); medial suture in ventral bar (absent in *C. triprolatum* vs present in *C. quadratum*); accessory piece of

male copulatory organ (MCO) shape (pincer-shaped in *C. triprolatum* vs clamp-shaped in *C. quadratum*) and vaginal opening (ventral in *C. triprolatum* vs marginal in *C. quadratum*; Table S3). On the contrary, *C. paranapanemense* have a similar morphology to *C. triprolatum*, but differs from this species mainly because it has a ventral bar with irregular anterior margin and a large posteromedial projection.

The divergence time estimates recovered that the origin of *Characithecium* diversification (i.e. its first-cladogenetic event) is dated back to approximately 11 Ma (95% highest posterior density (HPD) = 17.03–7.63 Ma; Figs 2 and 4), which corresponds to the middle Miocene. It was estimated that the clade *C. paranapanemense* (*C. triprolatum* + *C. quadratum*) evolved approximately 0.96 Ma (95% HPD = 1.95–0.13 Ma). *Characithecium costaricensis* diverged from its sister group at around 5.58 Ma (95% HPD = 8.99–2.95 Ma), and the divergence between *C. robustum* and *C. chascomusensis* was estimated at approximately 0.66 Ma (95% HPD = 1.95–0.01 Ma).

The results of the species-delimitation methods (GMYC and bPTP) based on a single locus did not recover the eight morphological entities presently recognized (Fig. 3). The species delimitation using the gene 28S rDNA supports four species in the GMYC analysis, while the bPTP analysis revealed six species (Fig. 3). Both methods indicate that *C. paranapanemense*, *C. triprolatum* and

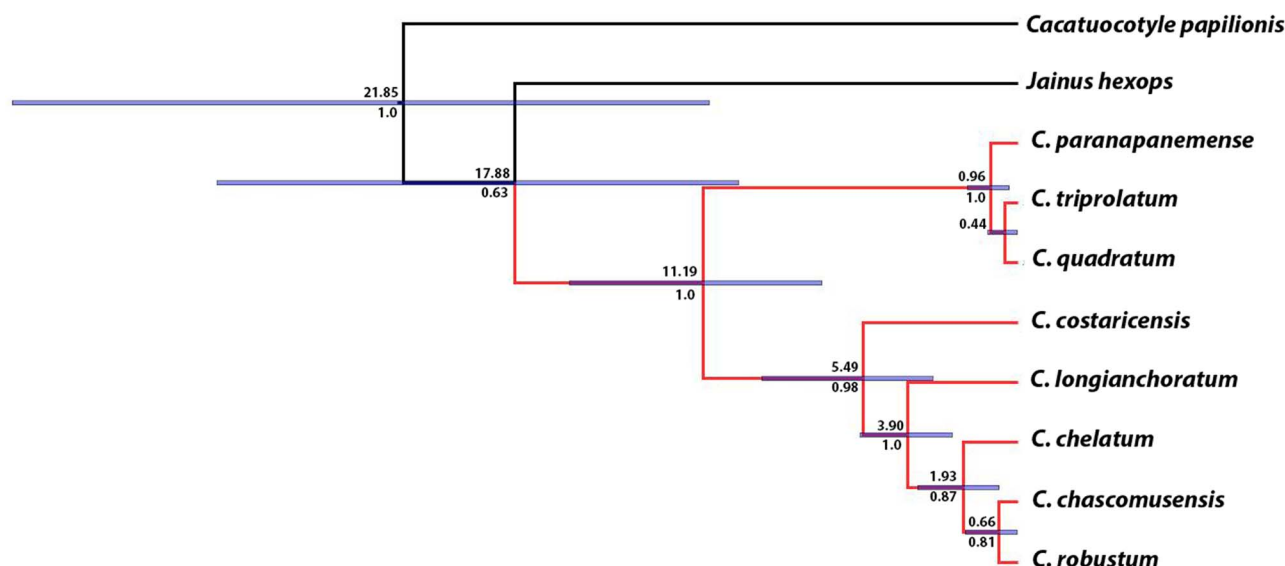

**Fig. 4.** Time-calibrated Species Tree hypothesis for *Characithecium* species based on 28S rDNA and 18S rDNA. Values below branches represent posterior probabilities. Time estimation (median age in Ma) is represented by values above branches. Blue bars represent the variation (95%) of the estimated dates.

*C. quadratum* may represent the same taxonomical unit. In addition, the GMYC, contrasting with the bPTP, did not recover *C. chelatum*, *C. robustum* and *C. chascomusensis* as distinct species (Fig. 3).

#### Characithecium occurrences and ecological traits

New hosts and expanded geographic distributions were detected for the species of *Characithecium* (Table 2). This extensive host repertoire for the parasite genus contains 32 fish species, with most interactions occurring at low prevalence rates. Two species of parasites occur exclusively in the members of *Oligosarcus* (*C. longianchoratum* and *C. robustum*; Table 2). In general, *Characithecium* species have higher prevalence rates in the species of *Oligosarcus* compared to that in *Astyanax* or *Psalidodon* species, and each parasite species usually has a high prevalence in a single host species among all observed host species (Table 2).

GLM analyses recovered that prevalence can be best explained by biotic and abiotic variables (Table 3). Host genus shown to be the variable that best explains the distribution of *C. costaricensis*, with the highest prevalence being found in *Astyanax* species (M3 and M4; Tables 2 and 3). The four variables together (M1 = host genus, altitude class, habitat type and ecoregion) were shown to better explain the distribution of *C. chascomusensis* (65%), with the highest prevalence being found in *Oligosarcus* species at higher altitudes (i.e. class 3 = more than 401 m), and in rivers in the coastal region of Brazil. Similarly, M1 was the model that best explained the distribution of *C. quadratum* (100%), with a higher prevalence in *Oligosarcus*, with distribution in La Plata river drainages.

The prevalences of *C. robustum* (76%) and *C. triprolatum* (73%) were best explained by habitat type and ecoregion (M10; Table 3). The high prevalence of *C. robustum* was associated with rivers in the Iguazu ecoregion, whereas *C. triprolatum* presented higher prevalences in rivers in the Paraguay ecoregion. The high prevalence for *C. longianchoratum* was best explained by M6, associated with the *Oligosarcus* species and distributed in La Plata river drainages.

In addition, the GLM analysis revealed that altitude class and ecoregion better explained the distribution of *C. chelatum* (M3 = 63%), with higher prevalence at high altitudes (i.e. more than 401 m) and in La Plata river and Laguna dos Patos drainages (Tables 2 and 3).

## Discussion

### Molecular phylogeny and species delimitations

The phylogenetic structure reconstructed for the available sequences of *Characithecium* spp. recognized a major clade of parasite species, which was composed of five of the eight *Characithecium* species studied here, which agree with the previous morphological delimitations (Rossin and Timi, 2015; Gallas et al., 2016; Zago et al., 2021).

The species delimitations based on GMYC and bPTP support fewer species compared to the morphological delimitation based on a combination of diagnostic characters. This result may be a consequence of the low genetic variability of ribosomal genes for the level of resolution necessary to discriminate closely related entities (e.g. when compared to mitochondrial genes; Ruttkay et al., 1992; Lemey et al., 2009). A larger number of species was estimated by bPTP compared to GMYC, which can be explained by the difference in how these species-delimitation methods work. While bPTP uses the number of nucleotide substitutions to model species boundaries, GMYC uses information from the distribution of divergence times, which can be influenced by how the phylogeny was time-calibrated (Zhang et al., 2013). A recent study found contrasting results for nematode parasites, where both models (GMYC and bPTP) recovered a larger number of species than morphological delimitation (Qing et al., 2019). This later study used, in addition to 18S rDNA and 28S rDNA, fragments of internal transcribed spacer (ITS) and cytochrome C oxidase subunit 1 (COI), which may have contributed to recognizing putative genetic variability (Qing et al., 2019). ITS and COI are known to have greater variability than ribosomal fragments (Bueno-Silva, 2012; Vanhove et al., 2013), where many studies also observed divergence between morphological and molecular data. For Monogenoidea, the vast majority of these studies reports a cryptic diversity, which is accessed after using more variable genes (Benovics et al., 2020; Ondračková et al., 2020; Pinacho-Pinacho et al., 2021).

The recent diversification of some groups of *Characithecium* and the divergence between *C. paranapanemense*, *C. triprolatum* and *C. quadratum* are estimated to have occurred during the Pleistocene, which may contribute to these species going unrecognized by the delimitation methods using molecular data. Despite putative recent speciation, several morphological characters can distinguish *C. triprolatum* and *C. quadratum*, such as vaginal opening position (e.g. ventral in *C. triprolatum* vs marginal in *C. quadratum*) and characters related to the ventral bar



**Table 2.** Species of *Characithecium* parasitizing gills of *Oligosarcus*, *Astyanax* and *Psalidodon* species, with prevalence, ecology and geographic distribution of hosts in South and Central America, and host voucher where the parasite was found. m, metres; Coa, coastal basins; Con, continental basin according to Wendt *et al.* (2019); FEOW, Freshwater Ecoregions of the World according to Abell *et al.* (2008)

| <i>Characithecium</i> species  | Host species (no. of specimens analysed) | Parasite prevalence (hosts with parasite) | Host vouchers            | Country/state                              | Hydrographic basin                  | FEOW                                       | Region      | Altitude (m) | Water body type |
|--|--|---|--------------------------|--|-------------------------------------|--|-------------|--------------|-----------------|
| <i>Characithecium costaricensis</i> (type species) (Price and Bussing, 1967) | <i>Oligosarcus hepsetus</i> (34)         | 5.9% (2)                                  | UFRGS 26953              | Brazil – Santa Catarina                    | Itajaí river                        | Southeastern Mata Atlantica                | Coa         | 69           | River           |
|  | <i>Oligosarcus macrolepis</i> (9)        | 11.1% (1)                                 | ICTJ2018021901           | Brazil – Minas Gerais                      | Jequitinhonha river                 | Northeastern Mata Atlantica                | Coa         | 723          | River           |
|  | <i>Astyanax brachypterygium</i> (6)      | 50% (3)                                   | UFRGS21849, UFRGS21881   | Brazil – Rio Grande do Sul                 | Taquari and Pelotas rivers          | Laguna dos Patos, Upper Uruguay            | Coa and Con | 1068–1181    | River, stream   |
|  | <i>Astyanax cremnobates</i> (10)         | 20% (2)                                   | UFRGS18440               | Brazil – Rio Grande do Sul                 | Upper Maquiné river                 | Tramandaí-Mampituba                        | Coa         | 870          | River           |
|  | <i>Astyanax mexicanus</i> (11)           | 36.4% (4)                                 | UFRGS23111               | Mexico                                     | –                                   | Lower Rio Grande-Bravo                     | –           | 772          | –               |
|  | <i>Astyanax</i> sp. (8)                  | 50% (4)                                   | UFRGS19746               | Brazil – Minas Gerais                      | Doce river                          | Northeastern Mata Atlantica                | Coa         | 1175         | Stream          |
|  | <i>Psalidodon eigenmanniorum</i> (14)    | 7.1% (1)                                  | UFRGS17263               | Brazil – Rio Grande do Sul                 | Tramandaí river                     | Tramandaí-Mampituba                        | Coa         | 12           | Lagoon          |
|  | <i>Psalidodon xiru</i> (8)               | 25% (2)                                   | UFRGS21975, UFRGS21983   | Brazil – Rio Grande do Sul                 | Ijuí and Maquiné rivers             | Tramandaí-Mampituba, Lower Uruguay         | Coa         | 54–127       | River, stream   |
|  | <i>Psalidodon rivularis</i> (8)          | 12.6% (1)                                 | UFRGS11261               | Brazil – Minas Gerais                      | Preto river                         | São Francisco                              | Con         | 692          | Stream          |
| <i>Characithecium chascomusensis</i> (Suriano, 1981)                         | <i>Oligosarcus acutirostris</i> (38)     | 21.1% (8)                                 | UFRGS22533, LBP10185     | Brazil – Bahia and Minas Gerais            | Santo Antonio and Mucuri rivers     | Northeastern Mata Atlantica                | Coa         | 41–174       | River           |
|  | <i>Oligosarcus argenteus</i> (36)        | 8.3% (3)                                  | CT1085, CT1089, LBP17391 | Brazil – Minas Gerais                      | Doce and Upper São Francisco rivers | Northeastern Mata Atlantica, São Francisco | Coa and Con | 663–980      | River, lagoon   |
|  | <i>Oligosarcus bolivianus</i> (4)        | 75% (3)                                   | ANSP68814, UFRGS27395    | Bolivia, Argentina                         | Bermejo river                       | Chaco                                      | Con         | 609–2200     | River, stream   |
|  | <i>Oligosarcus brevioris</i> (23)        | 21.7% (5)                                 | UFRGS14994, UFRGS24268   | Brazil – Rio Grande do Sul, Santa Catarina | Uruguai and Canoas rivers           | Upper Uruguay                              | Con         | 700–792      | River, stream   |

(Continued)



Table 2. (Continued.)

| Characithecium species                             | Host species (no. of specimens analysed) | Parasite prevalence (hosts with parasite) | Host vouchers  | Country/state  | Hydrographic basin  | FEOW  | Region      | Altitude (m) | Water body type       |
|--|--|---|--|--|---|---|-------------|--------------|-----------------------|
|  | <i>O. hepsetus</i> (34)                  | 38.2% (13)                                | UFRGS26953   | Brazil – São Paulo, Rio de Janeiro, Espírito Santo, Santa Catarina | Ribeira de Iguape and Itajaí rivers. Coastal basins of Rio de Janeiro and Espírito Santo  | Ribeira de Iguape, Northeastern Mata Atlantica, Fluminense, Southeastern Mata Atlantica | Coa         | 13–94        | River, stream, lagoon |
|  | <i>Oligosarcus jacuiensis</i> (22)       | 22.8% (5)                                 | Material not catalogued  | Brazil – Rio Grande do Sul   | Upper Jacuí and Taquari rivers  | Laguna dos Patos  | Coa         | 293–471      | River                 |
|  | <i>Oligosarcus jenynsii</i> (37)         | 24.3% (9)                                 | UFRGS22006, UFRGS17472, and additional not catalogued material                       | Brazil – Rio Grande do Sul   | Tramandaí and Ibicuí rivers, Laguna dos Patos system                                      | Laguna dos Patos, Lower Uruguay, Tramandaí-Mampituba                                    | Coa and Con | 4–119        | River, lagoon         |
|  | <i>Oligosarcus longirostris</i> (6)      | 16.6% (1)                                 | UFRGS25342   | Brazil – Paraná  | Iguaçu river  | Iguaçu  | Con         | 229          | River                 |
|  | <i>Oligosarcus paranensis</i> (13)       | 23% (3)                                   | UFRGS25343   | Brazil – Paraná  | Piquiri river   | Upper Paraná  | Con         | 403          | River                 |
|  | <i>Oligosarcus robustus</i> (26)         | 61.6% (16)                                | UFRGS17242, UFRGS21402, UFRGS11000, UFRGS19946, UFRGS17248, UFRGS10991, UFRGS27064   | Brazil – Rio Grande do Sul   | Laguna dos Patos and Laguna Mirim systems and Três Forquilhas, Tramandaí and Jacuí rivers | Laguna do Patos, Tramandaí-Mampituba  | Coa         | 2–133        | River, lagoon         |
|  | <i>Oligosarcus solitarius</i> (13)       | 61.5% (8)                                 | UFRGS19056   | Brazil – Minas Gerais  | Doce river  | Northeastern Mata Atlantica   | Coa         | 258          | Lagoon                |
|  | <i>Oligosarcus varii</i> (21)            | 4.8% (1)                                  | UFRGS22701   | Brazil – Rio Grande do Sul   | São Marcos river  | Laguna dos Patos  | Coa         | 552          | River                 |
|  | <i>Astyanax bagual</i> (6)               | 50% (3)                                   | UFRGS12296   | Brazil – Rio Grande do Sul   | Taquari river   | Laguna dos Patos  | Coa         | 179          | River                 |
|  | <i>Astyanax douradilho</i> (6)           | 50% (3)                                   | UFRGS18390   | Brazil – Rio Grande do Sul   | Maquiné river   | Tramandaí-Mampituba   | Coa         | 72           | River                 |
|  | <i>Astyanax henseli</i> (10)             | 20% (2)                                   | UFRGS19598, UFRGS18227   | Brazil – Rio Grande do Sul   | Upper Jacuí river   | Laguna dos Patos  | Coa         | 272          | River                 |
| <i>Characithecium chelatum</i> Rossin & Timi, 2015 | <i>O. argenteus</i> (36)                 | 44.5% (16)                                | CT (3396, 3397, 3398), CT (3403, 3405, 3406, 3407, 3408, 3412), UFRGS19745, LBP17391 | Brazil – Minas Gerais  | Doce and Upper São Francisco rivers   | Northeastern Mata Atlantica, São Francisco  | Coa and Con | 606–980      | River, stream, lagoon |

|   |             |  |   |  |  |     |              |                  |
|---|-------------|--|---|--|--|-----|--------------|------------------|
| <i>O. bolivianus</i> (4)                | 100% (4)    | ANSP68814,<br>UFRGS27395,<br>UFRGS27394                              | Bolivia,<br>Argentina                               | Bermejo river                          | Chaco                                      | Con | 609–<br>2200 | River,<br>stream |
| <i>O. brevioris</i> (23)                | 8.7% (2)    | UFRGS14994,<br>UFRGS24268  | Brazil – Rio<br>Grande do<br>Sul, Santa<br>Catarina | Uruguai and Canoas<br>rivers           | Upper Uruguay                              | Con | 700–792      | River,<br>stream |
| <i>O. hepsetus</i> (34)                 | 8.8% (3)    | UFRGS 26953  | Brazil – São<br>Paulo, Santa<br>Catarina            | Ribeira de Iguape<br>and Itajaí rivers | Ribeira de Iguape, South<br>Mata Atlantica | Coa | 42–69        | River            |
| <i>O. jacuiensis</i> (22)               | 4.6% (1)    | Material not<br>catalogued   | Brazil – Rio<br>Grande do<br>Sul                    | Upper Jacuí river                      | Laguna dos Patos                           | Coa | 471          | River            |
| <i>O. jenynsii</i> (37)                 | 13.5% (5)   | UFRGS17472, and<br>additional material<br>not catalogued             | Brazil – Rio<br>Grande do<br>Sul                    | Caí, Tramandaí and<br>Maquiné rivers   | Laguna dos Patos,<br>Tramandaí-Mampituba   | Coa | 4–802        | River,<br>lagoon |
| <i>O. longirostris</i> (6)              | 33.3% (2)   | UFRGS25342   | Brazil –<br>Paraná                                  | Iguaçu river                           | Iguaçu                                     | Con | 229          | River            |
| <i>Oligosarcus<br/>oligolepis</i> (14)  | 42.9% (6)   | UFRGS21466,<br>UFRGS24011,<br>UFRGS24012,<br>UFRGS8017,<br>UFRGS7534 | Brazil – Rio<br>Grande do<br>Sul                    | Uruguay, Ibicuí and<br>Negro rivers    | Lower Uruguay                              | Con | 35–150       | River,<br>stream |
| <i>O. paranensis</i> (13)               | 53.84% (7)  | UFRGS25343,<br>UFRGS24341,<br>MUZUEL14674                            | Brazil –<br>Paraná                                  | Tibagi, Piquiri and<br>Ivaí rivers     | Upper Paraná                               | Con | 403–572      | River            |
| <i>Oligosarcus<br/>perdido</i> (10)     | 40% (4)     | ZUFMS5473,<br>ZUFMS5461  | Brazil – Mato<br>Grasso do Sul                      | Perdido river                          | Paraguay                                   | Com | 456–519      | River            |
| <i>Oligosarcus pintoii</i><br>(18)      | 55.54% (10) | UFRGS22535   | Brazil – São<br>Paulo                               | Rio Grande river                       | Upper Paraná                               | Con | 479          | Stream           |
| <i>Oligosarcus<br/>planaltinae</i> (11) | 54.56% (6)  | UFRGS9887,<br>LBP17054   | Brazil –<br>Distrito<br>Federal                     | Paranaíba river                        | Upper Paraná                               | Con | 870–939      | Stream           |
| <i>O. varii</i> (21)                    | 80% (17)    | UFRGS18084,<br>UFRGS22700,<br>UFRGS22701                             | Brazil – Rio<br>Grande do<br>Sul                    | São Marcos river                       | Laguna dos Patos                           | Coa | 552–714      | River,<br>stream |
| <i>A. brachypterygium</i><br>(6)        | 83.33% (5)  | UFRGS21881   | Brazil – Rio<br>Grande do<br>Sul                    | Taquari river                          | Laguna dos Patos                           | Coa | 1068         | River            |
| <i>A. cremnobates</i><br>(10)           | 10% (1)     | UFRGS18430   | Brazil – Rio<br>Grande do<br>Sul                    | Upper Maquiné river                    | Tramandaí-Mampituba                        | Coa | 870          | River            |
| <i>A. henseli</i> (10)                  | 10% (1)     | UFRGS19598   | Brazil – Rio<br>Grande do<br>Sul                    | Emboabinha lagoon                      | Laguna dos Patos                           | Coa | 5            | Lagoon           |

(Continued)

Table 2. (Continued.)

| Characithecium species                                    | Host species (no. of specimens analysed) | Parasite prevalence (hosts with parasite) | Host vouchers                                      | Country/state                      | Hydrographic basin  | FEOW                               | Region      | Altitude (m) | Water body type       |
|---|--|---|--|------------------------------------|---|------------------------------------|-------------|--------------|-----------------------|
|   | <i>P. eigenmanniorum</i> (14)            | 14.22% (2)                                | UFRGS17263   | Brazil – Rio Grande do Sul         | Tramandaí river   | Tramandaí-Mampituba                | Coa         | 12           | Lagoon                |
|   | <i>Psolidodon paranae</i> (6)            | 16.67% (1)                                | UFRGS15071   | Brazil – Minas Gerais              | Paranaíba river   | Upper Paraná                       | Con         | 761          | River                 |
|   | <i>P. xiru</i> (8)                       | 37.55% (3)                                | UFRGS21983   | Brazil – Rio Grande do Sul         | Ijuí and Maquiné rivers                                       | Tramandaí-Mampituba, Lower Uruguay | Coa and Con | 17–197       | Stream                |
| <i>Characithecium longianchoratum</i> Rossin & Timi, 2015 | <i>O. bolivianus</i> (4)                 | 75% (3)                                   | ANSP68814, UFRGS27395, UFRGS27394                  | Bolivia, Argentina                 | Bermejo river   | Chaco                              | Con         | 609–2200     | River, stream         |
|   | <i>O. hepsetus</i> (34)                  | 17.62% (6)                                | UFRGS18903, UFRGS18757, LBP2875                    | Brazil – São Paulo, Rio de Janeiro | Ribeira de Iguape River and coastal basin of Rio de Janeiro   | Ribeira de Iguape, Fluminense      | Coa         | 18–59        | River, stream         |
|   | <i>O. jacuiensis</i> (22)                | 9.09% (2)                                 | Material not catalogued                            | Brazil – Rio Grande do Sul         | Taquari river   | Laguna dos Patos                   | Coa         | 862          | River                 |
|   | <i>O. jenynsii</i> (37)                  | 21.66% (8)                                | UFRGS12760, UFRGS22006, UFRGS10698                 | Brazil – Rio Grande do Sul         | Caí, Jaguarão, Ibicuí and Uruguai rivers                      | Laguna dos Patos, Lower Uruguay    | Coa and Con | 4–790        | River, stream, lagoon |
|   | <i>O. oligolepis</i> (14)                | 28.55% (4)                                | UFRGS24011, UFRGS24012, UFRGS19869                 | Brazil – Rio Grande do Sul         | Ibicuí and Negro rivers                                       | Lower Uruguay                      | Con         | 110–150      | River, stream         |
|   | <i>O. paranensis</i> (13)                | 15.35% (2)                                | UFRGS25343   | Brazil – Paraná                    | Piquirí river   | Upper Paraná                       | Con         | 403          | River                 |
|   | <i>O. robustus</i> (26)                  | 19.23% (5)                                | UFRGS10991, and additional material not catalogued | Brazil – Rio Grande do Sul         | Bacupari, Corvina and Mangueira lagoons, and Laguna dos Patos | Laguna dos Patos                   | Coa         | 4–12         | Lagoon                |
| <i>Characithecium quadratum</i> Rossin & Timi, 2015       | <i>O. bolivianus</i> (4)                 | 75% (3)                                   | ANSP68814, UFRGS27395, UFRGS27394                  | Bolivia, Argentina                 | Bermejo river   | Chaco                              | Con         | 609–2200     | River, stream         |
|   | <i>O. hepsetus</i> (34)                  | 2.95% (1)                                 | UFRGS26953   | Brazil – Santa Catarina            | Itajaí river  | Southeastern Mata Atlantica        | Coa         | 69           | River                 |
|   | <i>O. jenynsii</i> (37)                  | 13.55% (5)                                | UFRGS17505, UFRGS17472, UFRGS24013                 | Brazil – Rio Grande do Sul         | Fortaleza, Corvina and Mangueira lagoons, and Jaguarão rivers | Laguna dos Patos                   | Coa         | 1–132        | Stream, lagoon        |

|  |                             |             |  |                            |  |  |             |         |                       |
|--|-----------------------------|-------------|--|----------------------------|--|--|-------------|---------|-----------------------|
|  | <i>O. oligolepis</i> (14)   | 42.83% (6)  | UFRGS23402,<br>UFRGS21466,<br>UFRGS24011,<br>UFRGS24012                          | Brazil – Rio Grande do Sul | Uruguai, Ibicuí and Negro rivers   | Lower Uruguay                              | Con         | 35–150  | River, stream         |
|  | <i>O. robustus</i> (26)     | 46.13% (12) | UFRGS17242,<br>UFRGS19946,<br>UFRGS17248,<br>UFRGS10991,<br>UFRGS27064           | Brazil – Rio Grande do Sul | Fortaleza, Corvina, Mangueira and Quadros lagoons, Jacuí and Laguna dos Patos system | Laguna do Patos, Tramandaí-Mampituba       | Coa         | 4–43    | Stream, lagoon        |
|  | <i>A. douradilho</i> (6)    | 33.36% (2)  | UFRGS18434,<br>UFRGS18444  | Brazil – Rio Grande do Sul | Upper Maquiné river  | Tramandaí-Mampituba                        | Coa         | 65–147  | River                 |
|  | <i>A. henseli</i> (10)      | 10% (1)     | UFRGS19598   | Brazil – Rio Grande do Sul | Emboabinha lagoon  | Laguna dos Patos                           | Coa         | 5       | River                 |
| <i>Characithecium robustum</i> Rossin & Timi, 2015                       | <i>O. jenynsii</i> (37)     | 32.44% (12) | UFRGS22006,<br>UFRGS17839,<br>UFRGS17472, and additional material not catalogued | Brazil – Rio Grande do Sul | Mirim, Mangueira, Corvina and Bacupari lagoons, Ibicuí and Rio Negro river           | Laguna dos Patos, Lower Uruguay            | Coa and Con | 2–165   | River, stream, lagoon |
|  | <i>O. longirostris</i> (6)  | 83.34% (5)  | UFRGS25342   | Brazil – Paraná            | Iguaçu river   | Iguaçu                                     | Con         | 229     | River                 |
|  | <i>O. oligolepis</i> (14)   | 7.14% (1)   | UFRGS21466   | Brazil – Rio Grande do Sul | Ibicuí river   | Lower Uruguay                              | Con         | 101     | River                 |
| <i>Characithecium triprolatum</i> Gallas, Calegari-Marques & Amato, 2016 | <i>O. acutirostris</i> (38) | 13.15% (5)  | UFRGS22533   | Brazil – Bahia             | Santo Antonio river  | Northeastern Mata Atlantica                | Coa         | 41      | River                 |
|  | <i>O. argenteus</i> (36)    | 30.56% (11) | CT (1079, 1086, 1087, 1089, 1091), LBP17391, LBP16316, UFRGS19745                | Brazil – Minas Gerais      | Doce and Upper São Francisco rivers  | Northeastern Mata Atlantica, São Francisco | Coa and Con | 663–980 | River, stream, lagoon |
|  | <i>O. brevioris</i> (23)    | 13.04% (3)  | UFRGS24283   | Brazil – Rio Grande do Sul | Taquari river  | Laguna dos Patos                           | Coa         | 1012    | Stream                |
|  | <i>O. hepsetus</i> (34)     | 20.57% (7)  | UFRGS18571,<br>UFRGS18700,<br>LBP2875, LBP7449                                   | Brazil – São Paulo         | Ribeira de Iguape River  | Ribeira de Iguape                          | Coa         | 42–94   | River, lagoon         |
|  | <i>O. jacuiensis</i> (22)   | 9.09% (2)   | Material not catalogued  | Brazil – Rio Grande do Sul | Taquari river  | Laguna dos Patos                           | Coa         | 452     | River                 |
|  | <i>O. jenynsii</i> (37)     | 10.82% (4)  | UFRGS24013,<br>UFRGS22006, and additional material not catalogued                | Brazil – Rio Grande do Sul | Corvina and Bacupari lagoons, Jaguarão, and Ibicuí rivers                            | Laguna dos Patos, Lower Uruguay            | Coa and Con | 7–119   | River, stream, lagoon |

(Continued)



Table 2. (Continued.)

| Characithecium species | Host species (no. of specimens analysed)    | Parasite prevalence (hosts with parasite) | Host vouchers                    | Country/state               | Hydrographic basin                           | FEOW                                  | Region      | Altitude (m) | Water body type |
|------------------------|---|---|----------------------------------|-----------------------------|--|---------------------------------------|-------------|--------------|-----------------|
|                        | <i>O. oligolepis</i> (14)                   | 14.28% (2)                                | UFRGS19869, UFRGS24011           | Brazil – Rio Grande do Sul  | Ibicuí and Negro rivers                      | Lower Uruguay                         | Con         | 110–140      | Stream          |
|                        | <i>O. paranensis</i> (13)                   | 23.07% (3)                                | UFRGS25343, UFRGS24341           | Brazil – Paraná             | Piquiri and Ivaí rivers                      | Upper Paraná                          | Con         | 403–572      | River           |
|                        | <i>O. perdido</i> (10)                      | 80% (8)                                   | ZUFMS5473, ZUFMS5461             | Brazil – Mato Grosso do Sul | Perdido river                                | Paraguay                              | Con         | 456–519      | River           |
|                        | <i>O. robustus</i> (26)                     | 15.32% (4)                                | UFRGS17242, UFRGS18458           | Brazil – Rio Grande do Sul  | Quadros lagoon, Mampituba and Maquiné rivers | Tramandaí-Mampituba, Laguna dos Patos | Coa         | 2–10         | Lagoon          |
|                        | <i>O. varii</i> (21)                        | 4.70% (1)                                 | UFRGS22701                       | Brazil – Rio Grande do Sul  | São Marcos river                             | Laguna dos Patos                      | Coa         | 552          | River           |
|                        | <i>A. cremnobates</i> (10)                  | 40% (4)                                   | UFRGS18440, UFRGS18430           | Brazil – Rio Grande do Sul  | Upper Maquiné river                          | Tramandaí-Mampituba                   | Coa         | 870          | River           |
|                        | <i>A. douradilho</i> (6)                    | 33.30% (2)                                | UFRGS18390                       | Brazil – Rio Grande do Sul  | Lower Maquiné river                          | Tramandaí-Mampituba                   | Coa         | 72           | River           |
|                        | <i>A. henseli</i> (10)                      | 50% (5)                                   | UFRGS18227                       | Brazil – Rio Grande do Sul  | Upper Jacuí river                            | Laguna dos Patos                      | Coa         | 272          | River           |
|                        | <i>Psolidodon dissensus</i> (6)             | 33.34% (2)                                | UFRGS17473                       | Brazil – Rio Grande do Sul  | Tramandaí river                              | Laguna dos Patos                      | Coa         | 4            | Lagoon          |
|                        | <i>Psolidodon</i> aff. <i>fasciatus</i> (8) | 62.50% (5)                                | UFRGS10946, UFRGS5215, UFRGS8892 | Brazil – Rio Grande do Sul  | Upper Jacuí and Uruguai rivers, Guaíba lake  | Laguna dos Patos, Lower Uruguay       | Coa and Con | 8–92         | Lagoon          |
|                        | <i>P. eigenmanniorum</i> (14)               | 14.28% (2)                                | UFRGS17263                       | Brazil – Rio Grande do Sul  | Tramandaí river                              | Tramandaí-Mampituba,                  | Coa         | 12           | Lagoon          |
|                        | <i>P. xiru</i> (8)                          | 25% (2)                                   | UFRGS21983                       | Brazil – Rio Grande do Sul  | Ijuí and Maquiné rivers                      | Tramandaí-Mampituba, Lower Uruguay    | Coa and Con | 54–127       | River, stream   |

**Table 3.** Best models selected by the GLM analysis that explain *Characithecium* prevalence

| Parasite species          | Best GLM | AICc  | Weight | ΔAICc | Variables included | Chi-squared | P value                    |
|---------------------------|----------|-------|--------|-------|--------------------|-------------|----------------------------|
| <i>C. costaricensis</i>   | M3       | 133.3 | 0.382  | 0.0   | Host genus         | 30.3347     | $2.588 \times 10^{-7***}$  |
|                           |          |       |        |       | Altitude class     | 8.5816      | 0.07245                    |
|                           | M4       | 133.7 | 0.315  | 0.4   | Host genus         | 36.091      | $1.455 \times 10^{-8***}$  |
|                           |          |       |        |       | Altitude class     | 29.177      | $7.197 \times 10^{-6***}$  |
| <i>C. chascomusensis</i>  | M1       | 352.8 | 1      | 0.0   | Host genus         | 30.185      | $2.789 \times 10^{-7***}$  |
|                           |          |       |        |       | Altitude class     | 29.177      | $7.197 \times 10^{-6***}$  |
|                           |          |       |        |       | Habitat type       | 8.547       | 0.01393*                   |
|                           |          |       |        |       | Ecoregion          | 46.388      | $2.423 \times 10^{-5***}$  |
| <i>C. chelatum</i>        | M9       | 399.1 | 0.632  | 0.0   | Altitude class     | 49.598      | $4.381 \times 10^{-10***}$ |
|                           |          |       |        |       | Ecoregion          | 58.335      | $2.293 \times 10^{-7***}$  |
|                           |          |       |        |       | M7                 | 400.7       | 0.280                      |
|                           |          |       |        |       | Habitat type       | 2.764       | 0.251                      |
|                           |          |       |        |       | Ecoregion          | 54.419      | $1.089 \times 10^{-6***}$  |
| <i>C. longianchoratum</i> | M6       | 187.0 | 0.6547 | 0.0   | Host genus         | 14.037      | 0.0008953***               |
|                           |          |       |        |       | Ecoregion          | 50.376      | $5.281 \times 10^{-6***}$  |
|                           | M1       | 188.7 | 0.2924 | 1.6   | Host genus         | 15.737      | 0.0003825***               |
|                           |          |       |        |       | Altitude class     | 2.119       | 0.7138447                  |
|                           |          |       |        |       | Habitat type       | 5.929       | 0.0615982                  |
|                           |          |       |        |       | Ecoregion          | 44.982      | $4.107 \times 10^{-5***}$  |
| <i>C. quadratum</i>       | M1       | 164.5 | 1      | 0.0   | Host genus         | 22.030      | $1.645 \times 10^{-5***}$  |
|                           |          |       |        |       | Altitude class     | 12.408      | 0.07456                    |
|                           |          |       |        |       | Habitat type       | 1.656       | 0.43699                    |
|                           |          |       |        |       | Ecoregion          | 46.593      | $2.242 \times 10^{-5***}$  |
| <i>C. robustum</i>        | M10      | 113.4 | 0.7610 | 0.0   | Habitat type       | 17.989      | 0.0001241***               |
|                           |          |       |        |       | Ecoregion          | 63.582      | $2.736 \times 10^{-8***}$  |
| <i>C. triprolatum</i>     | M10      | 368.6 | 0.7308 | 0.0   | Habitat type       | 7.177       | 0.02763*                   |
|                           |          |       |        |       | Ecoregion          | 49.150      | $8.466 \times 10^{-6***}$  |

AICc, Akaike information criterion; ΔAICc, delta AICc; weight, weight of each model in the analysis.

Chi-squared is the statistic test used in ANOVA.

Significant values: \*\*\* $P \leq 0.001$ ; \* $P \leq 0.05$ .

morphology (e.g. posteromedial projection and suture in the ventral bar and ventral bar shape; Rossin and Timi, 2015; Gallas *et al.*, 2016). On the contrary, *C. paranapanemense* has a similar morphology to *C. triprolatum*. However, according to Zago *et al.* (2021), these species differ mainly concerning the MCO (with base possibly fused to the proximal portion of the dorsal subunit of the accessory piece in *C. triprolatum*) and the shape of the ventral bar, whereas *C. paranapanemense* has a ventral bar with an irregular anterior margin and a large posteromedial projection while *C. triprolatum* has a ventral bar with a regular anterior margin and a short median projection. Thus, we do not propose any nomenclatural change (e.g. synonymization of *C. paranapanemense*, *C. triprolatum* and *C. quadratum*) because morphological and molecular data may reach congruence when a wider variety of genetic markers are used in the study of *Characithecium* species. Furthermore, future analyses including *C. bifurcuprolatum* may provide more information on genetic data and present a new hypothesis of relationship.

### Ecological factors influencing *Characithecium* prevalence

*Characithecium* spp. parasitize species of *Oligosarcus*, *Astyanax* and *Psalidodon*, and depict a wide geographical distribution throughout drainages in southeastern South America. We report

the new occurrence of *Characithecium* in 28 additional host species. *Characithecium* seems to explore similar resources since it occurs in phylogenetically close hosts (Wendt *et al.*, 2019; Mirande, 2020; Terán *et al.*, 2020).

Until recently, *Characithecium* has been observed only in a few species of *Astyanax* and only one species of *Oligosarcus* and *Psalidodon*. Species of this genus have never been reported in the species of other host fish genera within Characidae, nor of other fish families or orders (Boeger and Vianna, 2006; Cohen *et al.*, 2013). This previous knowledge on the distribution of *Characithecium* species suggested a high host specificity and strong evidence of host–parasite coevolution (see Rossin and Timi, 2015). However, the greater sampling effort of the present study revealed that all species of *Characithecium* can use a wide range of host species, sharing members of the closely related species of *Astyanax*, *Psalidodon* and *Oligosarcus*. These host–parasite associations seem to be consistent with the results found by Mendoza-Palmero *et al.* (2020), which studied a new species of *Ameloblastella* and other dactylogyrids species parasitizing Neotropical catfish (e.g. species of Pimelodidae) and recovered that the parasites do not exhibit strict host–parasite associations at the genus or species level, but rather at the family or subfamily level.

We also found contrasting levels of prevalence values within *Characithecium* spp. on distinct host species. High prevalence is

generally explained with distinct ecological and geographical variables, such as host genus, habitat type and ecoregions. *Characithecium* spp. tended to be more prevalent when associated with *Oligosarcus* species and with certain ecological conditions of their hosts (such as inhabiting rivers or high altitudes), but also with other variables considered (e.g. ecoregion distribution). These results reveal the ability of these parasites to explore a diverse environment that is variable in biotic (e.g. hosts) and abiotic features. The absence of a clear pattern between the prevalence and ecological and geographical aspects suggests that species of *Characithecium* are ecologically flexible.

Several studies have demonstrated the great flexibility of parasites in exploring a wide range of resources and with different ecological predictors (Braga *et al.*, 2015; Mendoza-Palmero *et al.*, 2020). Many studies have already investigated the factors that could be related to different abundances in monogenoid species, with body size and geographic distance from hosts being correlated with variations in abundance (Poulin and Justine, 2008; Poulin *et al.*, 2011a). In the same way, a recent study sought to understand the variation of ecological parameters (e.g. abundance and prevalence of parasite) of *Aglaiogyrodactylus* spp. (Gyrodactylidae) among host species (fishes of Loricariidae family; Patella *et al.*, 2017). According to the authors, differences in host use parameters are directly related to the level of compatibility, that is, the capacity of the parasite species to establish its population in each host. Therefore, more compatible host species are more intensively parasitized, and alternative hosts presented abundances at least twice as small as the first ones (Patella *et al.*, 2017). Lower abundances apparently indicate less compatible host species (Patella *et al.*, 2017).

Although host specificity has been defined historically as the number of hosts used by the parasite (Poulin, 1992; Kearn, 1994; Huyse and Volckaert, 2005; Poulin *et al.*, 2011b), it is now recognized by how parasites are specialized to the resource (s) their hosts represent and not only to their taxonomy or phylogeny (although these can represent adequate proxies to the quality and quantity of resources) (Brooks and McLennan, 2002; Brooks *et al.*, 2019; Agosta and Brooks, 2020). Most elements that compose these resources are likely heritable and conserved in closely related hosts (see also Brooks and Agosta, 2012). Hence, the present study indicates that species of *Characithecium* exploit resources that are unique to the host clade they parasitize (*Astyanax* (*Andromakhe* (*Psalidodon* + *Oligosarcus*))) while occurring under a broad range of environmental conditions. A comprehensive analysis of host–parasite networks in a geographic context should provide a complete understanding of the historical processes associated with the evolution of this host–parasite system.

The discussion above is directly linked to the Stockholm paradigm, representing an alternative theoretical framework for understanding host–parasite interactions (Brooks *et al.*, 2014, 2019). This paradigm purports that parasites are resource trackers (as opposed to trackers of the host phylogeny) and diversify mostly by host switching. The Stockholm paradigm suggests that a parasite can readily infect compatible hosts by ecological fitting (Janzen, 1985) if the encounter between the symbionts presents itself (see also Araujo *et al.*, 2015). Compatibility (or capacity) and opportunity determine the realized fitness space (Brooks *et al.*, 2019; =the operative environment of Agosta and Klemens, 2008) of consumer species, which is envisioned as the host-repertoire of a parasite species. Hence, colonization of new host species may result from factors such as phylogeny (a proxy to compatibility) and geographic proximity, as well as biological and ecological conditions (the later representing determinants of opportunity).

Indeed, monogenoids (Dactylogyridae) that parasitize Neotropical freshwater fishes show different association patterns

depending on the host taxonomic group (Braga *et al.*, 2015). For instance, within the most species-rich host group, the Characiformes, parasites generally share hosts that are closely related phylogenetically (i.e. likely as a proxy to similar resources). In contrast, for another group, the Siluriformes, environmental characteristics and geographical proximity (i.e. determinants of opportunity) presented a more significant effect on the level of host sharing (Braga *et al.*, 2015). Therefore, the association between *Characithecium* species and their hosts seems to follow the pattern observed for other monogenoids in Characiformes, in which a close phylogenetic relationship of their hosts has an important effect.

The wide geographical distribution of *Characithecium* species may be associated with the evolutionary history of the hosts and dispersal events that may, in turn, have provided various opportunities for new host colonization. The host *Oligosarcus*, for example, is estimated to have an ancestral area in the Brazilian crystalline shield, and from there, two clades diverged and dispersed across La Plata river system tributaries and coastal drainages of southeastern South America (Wendt *et al.*, 2019). GLM analyses indicate that the high prevalence rates were generally associated with ecoregions that compose tributaries of the La Plata river basin (e.g. Iguacu, Paraguay and Chaco), being the region marked by the diversification of one clade of *Oligosarcus* at approximately 3 Ma (Wendt *et al.*, 2019). Subsequent dispersal events of *Oligosarcus* spp. from continental basins to coastal basins and from coastal basins to continental basins, dated to late Pleistocene, may have created new opportunities for the parasites to colonize new hosts on new geographic areas, even if the hosts currently have low prevalence rates.

Finally, the diversification of *Characithecium* and its relationship with its hosts demonstrated numerous particularities, which are added to the complex formation of drainages in South America. Such levels of complexities demonstrate the need to carry out increasingly interactive studies, including different types of information (morphological, molecular, ecological and others), and use increasingly complete databases to understand the evolutionary history of species and their associations. Then, the present study used a wide range of samples from many scientific collections that provided the largest number of host–parasite associations from many locations. Therefore, biological collections were very important to reconstruct a comprehensive phylogenetic relationship for *Characithecium* and to describe a broad host–parasite relationship in rivers of South America.

**Supplementary material.** The supplementary material for this article can be found at <https://doi.org/10.1017/S0031182022000221>.

**Acknowledgements.** We acknowledge all the financial institutions (listed below) that contributed to this study being carried out. We thank Dr Lia Lunaschi, the curator of the helminthological collection at Colección de Invertebrados del Museo de La Plata, for providing photos of the holotypes of the several *Characithecium* species. We thank Dr Marcelo Knoff, the curator of the helminthological collection of the Instituto Oswaldo Cruz, Rio de Janeiro, Brazil (CHIOC), for providing *Characithecium* vouchers in this important zoological collection. We thank the curators and personnel of the following ichthyological collections for providing material: F. Langeani (DZSJRP); C. Oliveira (LBP); C. Lucena (MCP); F. Jerep and O. Shibatta (MZUEL) and F. Carvalho (ZUFMS). We also thank V. Tkach, J. Weckstein and L. Bachmann for help and comments provided on the molecular work on parasites, host–parasite relationships and for many other discussions. We thank A. Ferrari, B. Sidlauskas and R. Vianna for comments on an early version of this manuscript.

**Author contributions.** E. W. W., L. R. M. and T. P. C. conceived and designed the study. E. W. W. and T. P. C. conducted data gathering. L. R. M. and T. P. C. checked the fish identifications and taxonomy. E. W. W. and W. A. B. checked the parasite identifications and taxonomy. E. W. W., M. P. B. and W. A. B. designed analyses of host–parasite

association. E. W. W., M. P. B., M. L. and T. P. C. conducted statistical analyses. E. W. W., L. R. M., M. P. B., W. A. B., M. L. and T. P. C. wrote the article.

**Financial support.** This study was funded by CAPES with a doctorate scholarship and was partially funded by Systematics Research Fund 2017/18, both granted to E. W. W. Field trips for collecting hosts were partially funded by a CNPq Universal grant (401204/2016-2) to L. R. M. T. P. C., during most of the duration of this project, was funded by CAPES with a PNPd postdoctoral fellowship.

**Conflict of interest.** None of the authors have any conflicts of interest.

**Ethical standards.** This project was approved by the institution's ethics committee (No. 32283) and followed all the proposed recommendations.

## References

- Abell R, Thieme ML, Revenga C, Bryer M, Kottelat M, Bogutskaya N, Coad B, Mandrak N, Balderas SC, Bussing W, Stiassny MLJ, Skelton P, Allen GR, Unmack P, Naseka A, Ng R, Sindorf N, Robertson J, Armijo E, Higgins JV, Heibel TJ, Wikramanayake E, Olson D, López HL, Reis RE, Lundberg JG, Sabaj MH and Petry P (2008) Freshwater ecoregions of the world: a new map of biogeographic units for freshwater biodiversity conservation. *BioScience* **58**, 403–414.
- Agosta SJ and Brooks DR (2020) *The Major Metaphors of Evolution: Darwinism Then and Now. Evolutionary Biology – New Perspectives on Its Development*. Cham: Springer International Publishing.
- Agosta SJ and Klemens JA (2008) Ecological fitting by phenotypically flexible genotypes: implications for species associations, community assembly and evolution. *Ecology Letters* **11**, 1123–1134.
- Agosta SJ, Janz N and Brooks DR (2010) How specialists can be generalists: resolving the 'parasite paradox' and implications for emerging infectious disease. *Zoologia* **27**, 151–162.
- Albert JS, Tagliacollo VA and Dagosta F (2020) Diversification of Neotropical freshwater fishes. *Annual Review of Ecology, Evolution, and Systematics* **51**, 27–53.
- Araújo SB, Braga MP, Brooks DR, Agosta SJ, Hoberg EP, von Hartenthal FW and Boeger WA (2015) Understanding host-switching by ecological fitting. *PLoS One* **10**, 1–17.
- Benovics M, Desdevises Y, Šanda R, Vukić J, Scheffler M, Doadrio I, Sousa-Santos C and Šimková A (2020) High diversity of fish ectoparasitic monogeneans (*Dactylogyrus*) in the Iberian Peninsula: a case of adaptive radiation? *Parasitology* **147**, 418–430.
- Boeger WA and Vianna RT (2006) Monogeneoidea, in Amazon fish parasites. In Thatcher VE (ed.), *Amazon Fish Parasites*. Bulgaria: Pensoft, pp. 42–116.
- Bouckaert R, Heled J, Kühnert D, Vaughan T, Wu CH, Xie D, Suchard MA, Rambaut A and Drummond AJ (2014) BEAST 2: a software platform for Bayesian evolutionary analysis. *PLoS Computational Biology* **10**, e1003537.
- Braga MP, Razzolini E and Boeger WA (2015) Drivers of parasite sharing among Neotropical freshwater fishes. *Journal of Animal Ecology* **84**, 487–497.
- Brooks DR and Agosta SJ (2012) Children of time: the extended synthesis and Major metaphors of evolution. *Zoologia* **29**, 497–514.
- Brooks DR and McLennan DA (2002) *The Nature of Diversity: An Evolutionary Voyage of Discovery*, 2nd Edn. Chicago, USA: University of Chicago Press.
- Brooks DR, Hoberg EP, Boeger WA, Gardner SL, Galbreath KE, Herczeg D, Mejía-Madrid HH, Rácz SE and Dursahinhan AT (2014) Finding them before they find us: informatics, parasites, and environments in accelerating climate change. *Comparative Parasitology* **81**, 155–164.
- Brooks DR, Hoberg EP and Boeger WA (2019) *The Stockholm Paradigm: Climate Change and Emerging Disease*, 1st Edn. Chicago: University of Chicago Press.
- Bueno-Silva M (2012) Genética molecular e sistemática animal: um breve histórico, contribuições e desafios. *Estudos de Biologia* **34**, 157–163.
- Burnham KP and Anderson DR (2002) *Model Selection and Multimodel Inference: A Practical Information and Theoretic Approach*, 2nd Edn. New York: Springer.
- Bush AO, Lafferty KD, Lotz JM, Shostak AW (1997) Parasitology meets ecology on terms: Margolis et al. revisited. *The Journal of Parasitology* **83**, 575–583.
- Cohen SC, Justo MC and Kohn A (2013) *South American Monogeneoidea Parasites of Fishes, Amphibians and Reptiles*. Rio de Janeiro: Oficina de Livros.
- Costa-Pereira R, Araújo MS, Paiva F and Tavares IER (2016) Functional morphology of the tetra fish *Astyanax lacustris* differs between divergent habitats in the Pantanal wetlands. *Journal of Fish Biology* **89**, 1450–1458.
- da Graca RJ, Fabrin TMC, Gasques LS, Prioli SMAP, Balbuena JA, Prioli AJ and Takemoto RM (2018) Topological congruence between phylogenies of *Anacanthorus* spp. (Monogenea: Dactylogyridae) and their Characiformes (Actinopterygii) hosts: a case of host–parasite cospeciation. *PLoS One* **13**, e0193408.
- da Silva BAF, da Silva RJ and Yamada FH (2021) *Characithecium* spp. (Monogenea: Dactylogyridae) from *Astyanax bimaculatus* (Characiformes: Characidae) in Northeast Brazil, with description of a new species. *Acta Parasitology* **66**, 1307–1315.
- Domingues MV and Boeger WA (2005) Neotropical Monogeneoidea. 47. Phylogeny and coevolution of species of *Rhinoxenus* (Platyhelminthes, Monogeneoidea, Dactylogyridae) and their Characiformes hosts (Teleostei, Ostariophysi) with description of four new species. *Zoosystema* **27**, 441–467.
- Ezard T, Fujisawa T and Barraclough TG (2009) SPLITS: Species' Limits by Threshold Statistics. R package version 1.0-18/r45. Available at <http://R-Forge.R-project.org/projects/splits/> (accessed 15 January 2020).
- Fujisawa T and Barraclough TG (2013) Delimiting species using single-locus data and the generalized mixed yule coalescent approach: a revised method and evaluation on simulated data sets. *Systematic Biology* **62**, 707–724.
- Gallas M, Calegari-Marques C and Amato SB (2016) A new species of *Characithecium* (Monogenea: Dactylogyridae) from external surface and gills of two species of *Astyanax* (Ostariophysi: Characidae) in southern Brazil. *Revista Mexicana de Biodiversidad* **87**, 903–907.
- Gioia I, Cordeiro NS and Artigas PT (1988) *Urocleidoides astyanacis* n. sp. (Monogenea: Ancyrocephalinae) from freshwater characids of the genus *Astyanax*. *Memórias do Instituto Oswaldo Cruz* **83**, 13–15.
- Heled J and Drummond AJ (2010) Bayesian inference of species trees from multilocus data. *Molecular Biology and Evolution* **27**, 570–580.
- Hoberg EP and Brooks DR (2015) Evolution in action: climate change, biodiversity dynamics and emerging infectious disease. *Philosophical Transactions of the Royal Society of London. Series B, Biological Sciences* **370**, 20130553.
- Humason GL (1979) *Animal Tissue Techniques*, 4th Edn. San Francisco: WH Freeman and Co.
- Huysse T and Volckaert FAM (2005) Comparing host and parasite phylogenies: *Gyrodactylus* flatworms jumping from goby to goby. *Systematic Biology* **54**, 710–718.
- Janzen DH (1985) On ecological fitting. *Oikos* **45**, 308–310.
- Katoh K, Misawa K, Kuma KI and Miyata K (2002) MAFFT: a novel method for rapid multiple sequence alignment based on fast Fourier transform. *Nucleic Acids Research* **30**, 3059–3066.
- Kearn GC (1994) Evolutionary expansion of the Monogenea. *International Journal for Parasitology* **24**, 1227–1271.
- Kearse M, Moir R, Wilson A, Stones-Havas S, Cheung M, Sturrock S, Buxton S, Cooper A, Markowitz S, Duran C, Thierer T, Ashton B, Mentjies P and Drummond A (2012) Geneious basic: an integrated and extendable desktop software platform for the organization and analysis of sequence data. *Bioinformatics (Oxford, England)* **28**, 1647–1649.
- Kritsky DC and Leiby PD (1972) Dactylogyridae (Monogenea) from the freshwater fish, *Astyanax fasciatus* (Cuvier), in Costa Rica, with descriptions of *Jainus hexops* sp. n., *Urocleidoides costaricensis*, and *U. heteroancistrum* combs. n. *Proceedings of the Helminthological Society of Washington* **39**, 227–230.
- Lanfear R, Calcott B, Ho SYW and Guindon S (2012) PartitionFinder: combined selection of partitioning schemes and substitution models for phylogenetic analyses. *Molecular Biology and Evolution* **29**, 1695–1701.
- Lemey P, Salemi M and Vandamme AM (2009) *The Phylogenetic Handbook: A Practical Approach to Phylogenetic Analysis and Hypothesis Testing*. Cambridge, UK: Cambridge University Press.
- Littlewood DTJ and Olson PD (2001) Small subunit rDNA and the Platyhelminthes: signal, noise, conflict and compromise. In Littlewood DTJ and Bray RA (eds), *Interrelationships of the Platyhelminthes*. New York: Taylor and Francis Publishing, pp. 262–278.
- Lucena CAS, Calegari BB, Pereira EHL and Dallegrave E (2013) O uso de óleo de cravo na eutanásia de peixes. *Boletim Sociedade Brasileira de Ictiologia* **105**, 20–24.
- Mendlová M and Šimková A (2014) Evolution of host specificity in monogeneans parasitizing African cichlid fish. *Parasites & Vectors* **7**, 69.



- Mendoza-Franco EF, Reina RG and Torchin ME (2009) Dactylogyrids (Monogeneoidea) parasitizing the gills of *Astyanax* spp. (Characidae) from Panama and Southeast Mexico, a new species of *Diaphorocleidus* and a proposal for *Characithecium* N. Gen. *Journal of Parasitology* **95**, 46–55.
- Mendoza-Palmero CA, Rossin MA, Irigoitia MM and Scholz T (2020) A new species of *Ameloblastella* Kritsky, Mendoza-Franco & Scholz, 2000 (Monogeneoidea: Dactylogyridae) from South American freshwater catfishes (Siluriformes: Pimelodidae). *Systematic Parasitology* **97**, 357–367.
- Miller M, Pfeiffer W and Schwartz T (2010) Creating the CIPRES science gateway for inference of large phylogenetic trees. In *Proceedings of the Gateway Computing Environments Workshop (GCE)*, New Orleans, LA.
- Mirande JM (2020) Morphology, molecules and the phylogeny of Characidae (Teleostei, Characiformes). *Cladistics* **35**, 282–300.
- Mollaret I, Lim LH and Justine J (2000) Phylogenetic position of the monogeneans *Sundanochus*, *Thaparocleidus*, and *Cichlidogyrus* inferred from 28S rDNA sequences. *International Journal for Parasitology* **30**, 659–662.
- See S, May RM and Harvey PH (1994) The reconstructed evolutionary process. *Philosophical Transactions of the Royal Society of London B: Biological Sciences* **344**, 305–311.
- Ondračková M, Seifertová M, Bryjová A, Leis E and Jurajda P (2020) Morphometric and genetic evidence for cryptic diversity in *Gyrodactylus* (Monogenea) infecting non-native European populations of *Ameiurus nebulosus* and *A. melas*. *Parasitology* **147**, 1700–1711.
- Patella L, Brooks DR and Boeger WA (2017) Phylogeny and ecology illuminate the evolution of associations under the Stockholm paradigm: *Aglaiogyrodactylus* spp. (Platyhelminthes, Monogeneoidea, Gyrodactylidae) and species of Loricariidae (Actinopterygii, Siluriformes). *Vie et Milieu* **67**, 91–102.
- Penn O, Privman E, Ashkenazy H, Landan G, Graur D and Pupko T (2010) GUIDANCE: a web server for assessing alignment confidence scores. *Nucleic Acids Research* **38**, 23–28.
- Pinacho-Pinacho CD, Calixto-Rojas M, García-Vásquez A, Guzmán-Valdivieso I, Barrios-Gutiérrez JJ and Rubio-Godoy M (2021) Species delimitation of *Gyrodactylus* (Monogenea: Gyrodactylidae) infecting the southernmost cyprinids (Actinopterygii: Cyprinidae) in the New World. *Parasitology Research* **120**, 831–848.
- Pons J, Barraclough T, Gomez-Zurita J, Cardoso A, Duran D, Hazell S, Kamoun S, Sumlin W and Vogler A (2006) Sequence-based species delimitation for the DNA taxonomy of undescribed insects. *Systematic Biology* **55**, 595–609.
- Poulin R (1992) Determinants of host-specificity in parasites of fresh-water fishes. *International Journal for Parasitology* **22**, 753–758.
- Poulin R and Justine JL (2008) Linking species abundance distributions and body size in monogenean communities. *Parasitology Research* **103**, 187–193.
- Poulin R, Blonar CA, Thieltges DW and Marcogliese DJ (2011a) The biogeography of parasitism in sticklebacks: distance, habitat differences and the similarity in parasite occurrence and abundance. *Ecography* **34**, 540–551.
- Poulin R, Krasnov BR and Mouillot D (2011b) Host specificity in phylogenetic and geographic space. *Trends in Parasitology* **27**, 355–361.
- Qing X, Bert W, Gamliel A, Bucki P, Duvrinin S, Alon T and Miyara SB (2019) Phylogeography and molecular species delimitation of *Pratylenchus capsici* N. sp., a new root-lesion nematode in Israel on pepper (*Capsicum annuum*). *Phytopathology* **109**, 847–858.
- Rambaut A, Suchard MA, Xie D and Drummond AJ (2014) Tracer v1.6. Available at <http://beast.bio.ed.ac.uk/Tracer> (accessed 29 August 2019).
- Ribeiro AC (2006) Tectonic history and the biogeography of the freshwater fishes from the coastal drainages of eastern Brazil: an example of faunal evolution associated with a divergent continental margin. *Neotropical Ichthyology* **4**, 225–246.
- Ribeiro AC and Menezes NA (2015) Phylogenetic relationships of the species and biogeography of the characid genus *Oligosarcus* Günther, 1864 (Ostariophysi, Characiformes, Characidae). *Zootaxa* **3949**, 41–81.
- Ronquist F, Teslenko M, Mark P, Ayres DL, Darling A, Höhna S, Larget B, Liu L, Suchard MA and Huelsenbeck JP (2012) MRBAYES 3.2: efficient Bayesian phylogenetic inference and model selection across a large model space. *Systematic Biology* **61**, 539–542.
- Rossin MA and Timi JT (2015) *Characithecium* (Monogeneoidea: Dactylogyridae) parasitic on the Neotropical fish *Oligosarcus jenynsii* (Teleostei: Characidae) from the Pampasic region, Argentina, with the emendation of the genus. *Zootaxa* **3893**, 382–396.
- Ruttkay H, Solignac M and Sperlich D (1992) Nuclear and mitochondrial ribosomal RNA variability in the obscure group of *Drosophila*. *Genetica* **85**, 143–179.
- Scarpa F, Cossu P, Sanna D, Lai T, Norenburg JL, Curini-Galletti M and Casu M (2015) An 18S rDNA and 28S rDNA-based clock calibration for marine Proseriata (Platyhelminthes). *Journal of Experimental Marine Biology and Ecology* **463**, 22–31.
- Tamura K and Nei M (1993) Estimation of the number of nucleotide substitutions in the control region of mitochondrial DNA in humans and chimpanzees. *Molecular Biology and Evolution* **10**, 512–526.
- Terán GE, Benítez MF and Mirande JM (2020) Opening the Trojan horse: phylogeny of *Astyanax*, two new genera and resurrection of *Psalidodon* (Teleostei: Characidae). *Zoological Journal of the Linnean Society* **190**, 1217–1234.
- Tkach V and Pawlowski J (1999) A new method of DNA extraction from the ethanol-fixed parasitic worms. *Acta Parasitologica* **44**, 147–148.
- Untergasser A, Nijveen H, Rao X, Bisseling T, Geurts R and Leunissen JA (2007) Primer3Plus, an enhanced web interface to Primer3. *Nucleic Acids Research* **35**, 71–74.
- Vanhove MPM, Tessens B, Schoelincx C, Jondelius U, Littlewood DTJ, Artois T and Huyse T (2013) Problematic barcoding in flatworms: a case-study on monogeneans and rhabdocoels (Platyhelminthes). *ZooKeys* **365**, 355–379.
- Wendt EW, Silva PC, Malabarba LR and Carvalho TP (2019) Phylogenetic relationships and historical biogeography of *Oligosarcus* (Teleostei: Characidae): examining riverine landscape evolution in southeastern South America. *Molecular Phylogenetics and Evolution* **140**, 106604.
- Zago AC, Franceschini L, Abdallah VD, Müller MI, Azevedo RK and da Silva RJ (2021) Morphological and molecular data of new species of *Characithecium* and *Diaphorocleidus* (Monogenea: Dactylogyridae) from Neotropical characid fishes. *Parasitology International* **88**, 102406.
- Zhang J, Kapli P, Pavlidis P and Stamatakis A (2013) A general Species delimitation method with applications to phylogenetic placements. *Bioinformatics (Oxford, England)* **29**, 2869–2876.