

Forum

DOI: 10.1017/S0373463302212023

Finding Distance – Not Knowing Height

Peter Ifland

KEY WORDS

1. History. 2. Sea. 3. Instruments.

Most older methods for determining distance depended on knowing the height of the object being observed. By measuring the angle subtended by the object, and then applying simple right-triangle trigonometry, the distance could be calculated. However, it is usually feasible, although a little more complicated, to determine distance not knowing height. This article will explain some of the techniques used for determining distance not knowing height. Two hand-held instruments from the beginning of the twentieth century are described that were specifically designed for this purpose.

A marine navigator will most often know the height of the object to which he wants to find the distance. Fifteenth century navigators kept careful journals, *rutters*, that told them the height of prominent landmarks that they could sight using the shadow square on the back of their quadrant. From the beginning of the sixteenth century onward, mariners were provided with increasingly detailed charts showing the heights of important navigation aids. Ships travelling in fleets were provided with information on the height of the masthead, the funnel and the stern light above the waterline on the other ships in company for use in keeping station. Even the height characteristics of enemy war ships were well known. Angle measuring instruments from the cross staff to the sextant were used to measure the angle subtended by the object, and simple trigonometry yielded distance. In later years, the doubly reflecting optics of the sextant were used to design highly functional distance-finding instruments that could be adjusted for height so as to readout distance directly (Ifland, 2002).

But how to find distance if the height of the object is not known? Over four hundred years ago, J. Werner and Petrus Apianus (Werner and Apianus, 1553) produced a woodcut of two surveyors determining the height and distance to a tower using cross staves to measure the angle subtended by the tower at two points along a straight line to the tower. Three hundred years later, Commander Becher of the Royal Navy (Becher, 1844) picked up this technique (Figure 1a) and gave us several others (Figure 1b and 1c) for finding distance at sea not knowing height.

Land-based artillery frequently faced the problem of finding range to a target without knowing its height. The problem is much easier to resolve on land where it is possible to measure the length of the base of a horizontal triangle using a chain or cord of known length or simply by pacing-off the distance. A number of instruments

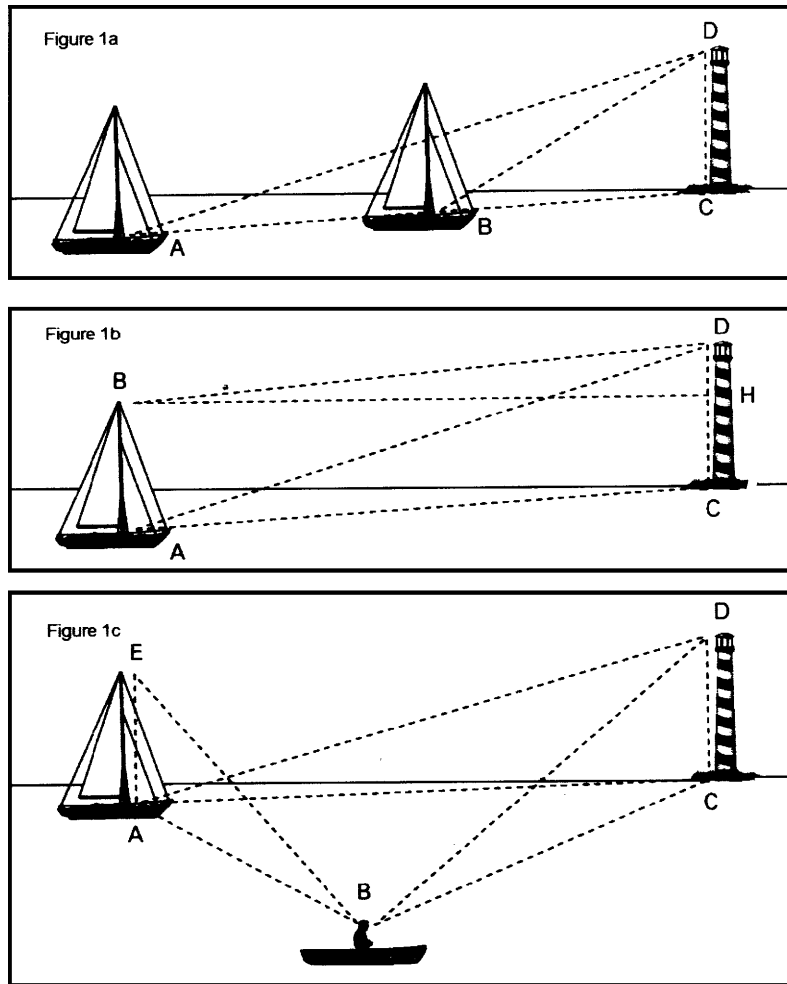

Figure 1. Cdr. Becher's methods for finding distance not knowing height. (Becher, 1844. Redrawn from Ifland, 1995). (a) At point A, measure the angle CAD. Then move the ship a known distance to point B and measure the angle CBD. The height of the lighthouse is $CD = BD \sin CBD$ and the distance is $AC = AB + BD \cos CBD$. (b) Measure the angle CAB. Climb to the top of the mast, a known height, and measure angle HBD using an artificial horizon. The height of the lighthouse above the water level is $CD = AB + BD \sin HBD +$ the height of the deck above water. (c) Measure the angle to the top of the lighthouse, CAD. Send a small boat out to point B. Distance $AB = AE \cotan ABE$, knowing the height of own ship's mast, AE. Determine the horizontal angles ABC and CAB. Knowing these angles and the distance AB, solve the triangle ABC using the law of sines to find the distance to the lighthouse, AC. The height of the lighthouse is $CD = AC \tan CAD$.

relying on an extension of the geometric principles illustrated in Figure 1c have been developed specifically for artillery applications, see Figure 2.

The simplest application of the concept is to establish the triangle CAB in Figure 2 with a right angle at A and with a known base length, AB. British Army rangefinders of the 1870s and 1880s such as the Steward Telemeter and the widely used Watkin Mekometer were based on this concept (Moss and Russell, 1988). They required two operators separated by a cord of standard length, twenty-five or thirty

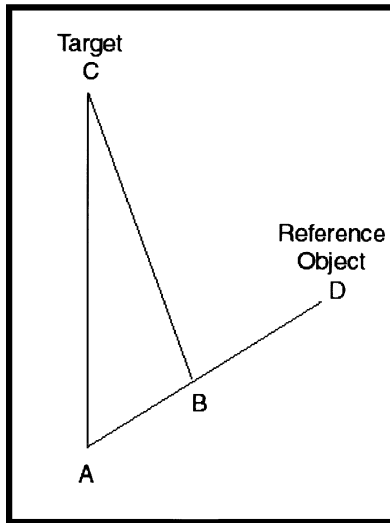

Figure 2. The triangle used in early artillery rangefinders.

yards. One operator at A carried an instrument that determined when the second operator at B was positioned at precisely ninety degrees from the line of sight to the target, AC. The second observer then measured the angle between the baseline and the target, angle ABC, using an instrument calibrated to read distance in yards ($AC = AB \tan ABC$). The system was sufficiently accurate under ideal conditions, but it required two operators and was easily broken under field conditions.

The basic concept of single-operator turn-of-the-twentieth-century artillery rangefinder instruments was to establish a horizontal triangle with two known angles and one known side and then solve the triangle mechanically using simple trigonometry. In operation, select a reference object D, and measure the angle between the target and the reference object, angle CAD. Move a measured distance, AB, the base of the triangle, in a straight line toward the reference object. Measure the new angle between the target and the reference object, angle CBD. Use the mechanical features of the instrument to solve for the distance to the observed object.

Figure 3 shows a simple instrument based on the above principle that was developed for artillery range finding – ‘Captain G. H. Fenner’s Range Finder made by Heath and Co. Ltd., Crayford, London. S. E.’ under British patent No. 3518 of 1892. George Hamilton Fenner was a Bachelor of Arts and a military tutor who once lived at 14, The Avenue, Bedford Park, Acton, Middlesex.

Fenner’s rangefinder operates on the principle illustrated in Figure 2. To find the range to the target, identify a reference object that is at an angle between 45 and 90 degrees from the target. Use the sextant features of the instrument to measure the angle between the target and the reference object, angle CAD, and then clamp the index arm in place. Increase the angle set on the index arm by precisely $1\frac{1}{2}$ degrees using the fine adjustment screw and the calibration lines on the index. Now, move on a straight line toward the reference object until the observed angle between the target and the reference object, angle CBD, reaches the increased value. Measure the distance travelled from the starting point to the new position, AB, the base of the triangle. Find the base length thus measured on the appropriate curve on the frame

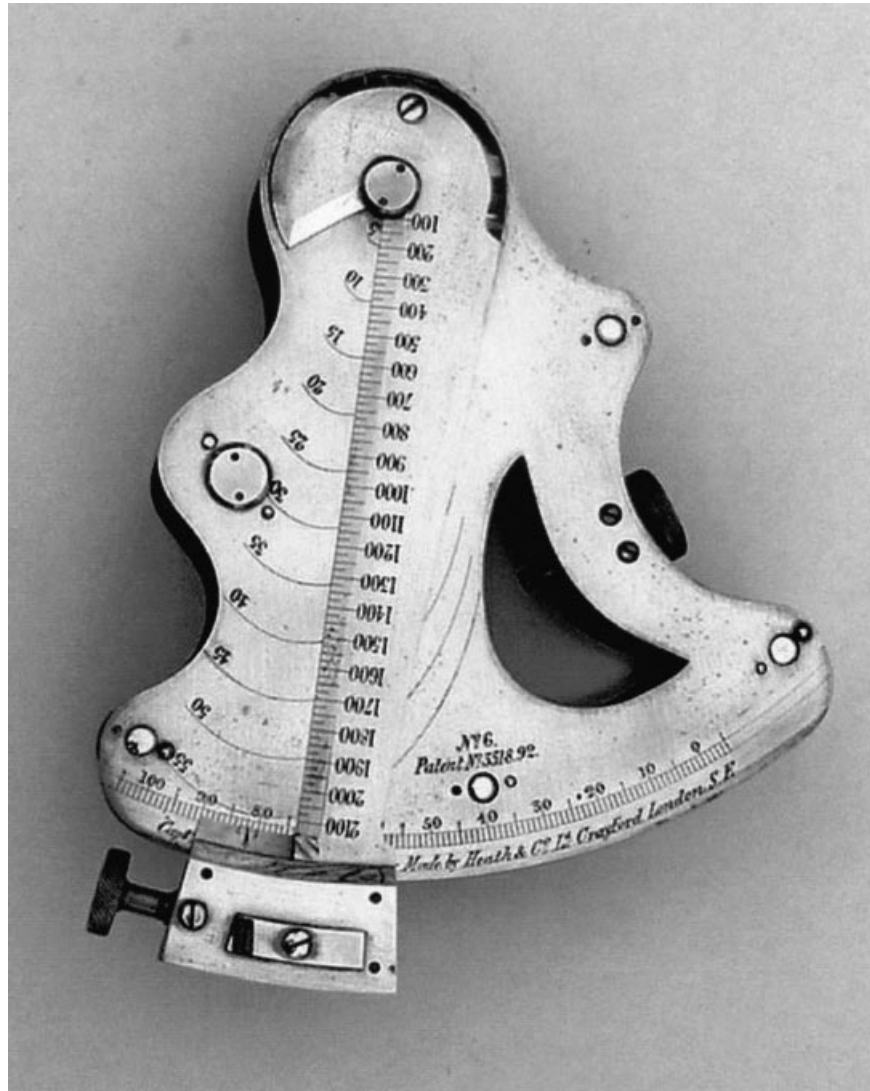

Figure 3. Fenner's Range Finder. The rangefinder is constructed like a double frame octant. The $4\frac{1}{2}$ -inch radius scale reads – 5 to 105 degrees. The edge of the index arm is calibrated in units of distance from 100 to 2100 in increments of 25. A series of curves representing the base lengths, AB, of a $1\frac{1}{2}$ -degree triangle, for which the instrument is calibrated, are drawn on the frame from 5 to 55 in increments of five. The instrument can be read in any convenient units of distance – yards, cables, metres, etc. depending on the units used to measure the base length. The curves are drawn so that the distance reading when the angle is set at 90 degrees equals the indicated base length multiplied by the cotangent of 90 degrees. For angles other than 90 degrees between the target and the object, the curves are drawn so that distance equals $AB \times \cotan 90^\circ \times \sin (CAD + 1\frac{1}{2})$ as indicated on the octant scale.

of the instrument, interpolating if necessary. Read the range to the target from the original position A off the scale of the index arm.

The instrument is calibrated so that the increased angle must be precisely $1\frac{1}{2}$ degrees. The advantage to using such a small angle is that the base is short – one does

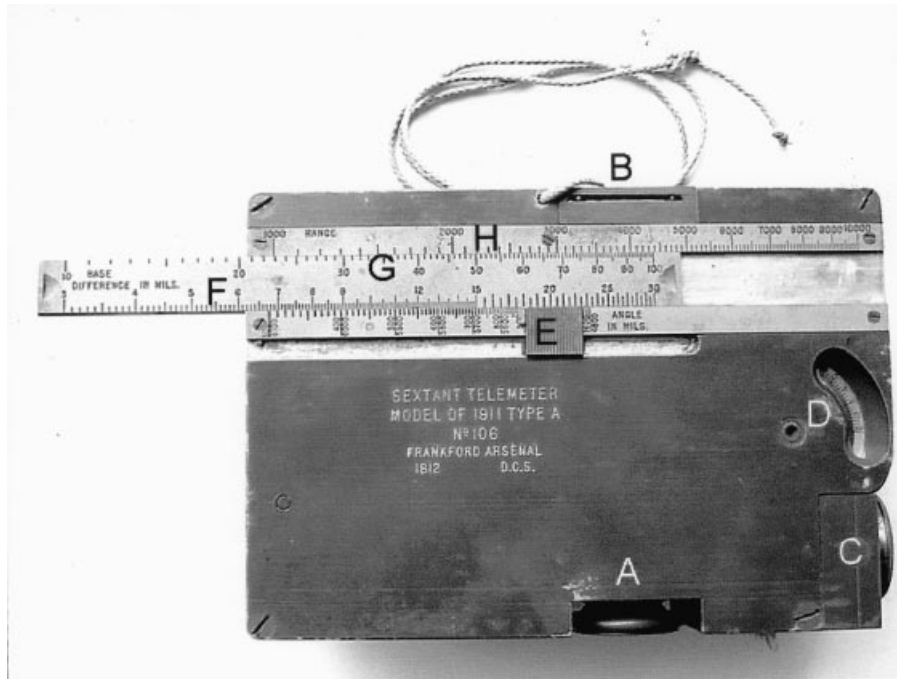

Figure 4. The Frankford Arsenal Sextant Telemeter. Two iron plates $4 \times 5\frac{1}{2}$ " separated by $\frac{1}{8}$ inch stanchions form the instrument. The optics of a sextant are sandwiched between the plates. A low-power telescope is at A, the half-silvered 'horizon glass' is at B. The calibrated knob C rotates the internal 'index mirror' so that the observed angle is registered on the scale D. The angles are calibrated in mils, $\frac{1}{6400}$ of a circle. A slide rule is provided to solve the triangle for distance: E reads for the angle CAD in Figure 2; F is the difference in the two angles (CBD–CAD); G is the base distance AB; and H is the range, AC. An internal pendulum device can be used to find elevation above the horizontal. A small magnetic compass, a prism for viewing at right angles, and cards for calibration round out the features.

not have to move very far to find the range. If the reference object is at 60 degrees from the target, the observer must move only 24.18 yards to measure a range of 800 yards.

An artillery range finder of very different design was developed by the US Army at the Frankford Arsenal located near Philadelphia in 1911 (Figure 4). The operating principle of the Frankford Telemeter is similar to that of the Fenner instrument in that it also used an identifiable object at an angle to the target and then established a base of measured distance. Contrary to the Fenner instrument that was calibrated for a precisely $1\frac{1}{2}$ degree change in bearing, the Frankford instrument used the slide rule to calculate range for any change in bearing of the target from the first to the second point of observation.

REFERENCES

- Becher, A. B. Cdr. RN. (1844) The Pendulum Artificial Horizon. *The Nautical Magazine*. No. 5, pp. 291–297, London.
- Moss, M. and Russell, I. (1988). *Range and Vision – The first Hundred Years of Barr & Stroud*. ISBN 1-85158-128-6. Mainstream Publishing Company, Edinburgh.

- Ifland, P. (1995). Finding Distance Off and Height of a Lighthouse. *Ocean Navigator*. Issue 65, pp. 43–44, Navigator Publishing Corp., Portland, Maine.
- Ifland, P (2002). Finding Distance – The Fiske Rangefinders. *This Journal* 55, 147–152.
- Ifland, P (2002). Finding Distance – The Haecke Rangefinder. *This Journal* 55, 323–326.
- Werner, J. and Apianus, P. (1553). *Introductio Geographica Petri Apiani*, In *Doctissimas Veneri Annotationes*, Ingolstadt. The Library, Cambridge University, Cambridge.

DOI: 10.1017/S037346330222202X

Collision Regulations – Not To Impede

Karen Williams

KEY WORDS

1. COLREGS.
2. Traffic Separation Schemes.
3. Marine collision avoidance.

I read with interest the comments made on Rule 10 of the COLREGS in ‘Collision Regulations – Discussion’ (Manley, 2002). I am currently studying for the final exam for the Class 4 qualification for captains of yachts over 24 metres and am thus being tutored in the officially accepted interpretation of the Rules. However, as a RYA instructor, I am also aware that the official interpretation of the expression ‘not to impede’, which appears in the Rules in several places, is in general not well understood by yachtsmen. The discussion of Rule 8(f) in MGN 28 ‘Observance of Traffic Separation Schemes’ is, I feel, not helpful to those without benefit of a formal training in the COLREGS such as is received by Merchant Navy personnel. There is no other M Notice on the subject.

In the context of the COLREGS, ‘impede’ is not open to interpretation as per common usage but is defined as stated in Guidance approved by the Maritime Safety Committee of the IMO in 1982 (Cockcroft and Lameijer, 1996). The expression ‘not to impede the passage or safe passage’ means that the vessel required to take this action does so before a risk of collision develops in order to allow sufficient sea room for the other vessel’s safe navigation, see Rule 8(f)(i). Furthermore, such a vessel is never relieved of this obligation even if a risk of collision does develop, see Rule 8(f)(ii); neither is she redefined as stand-on or give-way. This is in effect a navigational concession to the power-driven vessel following the traffic lane and is not to be confused with ‘keeping out of the way’ of another vessel, which is the action of the give-way vessel when a risk of collision develops between two vessels, see Rule 16. The vessel whose passage is not to be impeded must comply with the Steering and Sailing Rules if a risk of collision does develop. She will then become either a stand-on or give-way vessel, see Rule 8(f)(iii).

We can now apply this understanding to Rule 10(j) regarding Traffic Separation Schemes. A power-driven vessel of less than 20 metres or a sailing vessel crossing a traffic lane, seeing on a steady bearing a power-driven vessel that is following a traffic lane, is required by Rule 10(j) to avoid impeding the safe passage of that power-driven vessel. She shall therefore take the appropriate avoiding action before a risk of collision develops. She is never relieved of this obligation even if a risk of collision develops with the power-driven vessel following the lane. A power-driven vessel that feels her passage is in danger of being impeded by the crossing vessel should sound

at least five short rapid blasts on her whistle and give the vessel time to comply with Rules 10(j) and 8(f)(i). If she does not comply and a risk of collision eventually develops, the power-driven vessel becomes a give-way or stand-on vessel and should take the appropriate action. The crossing vessel is still not relieved of her duty to avoid impeding the safe passage of the other vessel, Rule 8(f)(ii) and should manoeuvre accordingly.

The mistake many yachtsmen make in interpreting 'safe passage' is that they think it is up to themselves to make this decision, whereas in fact they are required to take action in sufficient time to prevent a risk of collision developing. Regarding the statement quoted by Pat Manley from Cooper (2001) in respect of Rule 17(c), this is a misunderstanding of the situation. It is not up to a sailing vessel or a vessel of less than 20 metres to interpret Rule 10 generously! The Rule makes it quite clear that the action to be taken by a sailing vessel, or a vessel of less than 20 metres, should be in accordance with Rule 8(f)(i); in other words, action shall be taken before a risk of collision develops to avoid impeding the safe passage of the power-driven vessel following the traffic lane, i.e. this is mandatory.

Rule 17(c) defines the action of a stand-on power-driven vessel in a crossing situation (i.e. when there is risk of collision) and basically states that, when taking action in accordance with Rule 17(a)(ii), a power-driven vessel shall not alter course to port for a power-driven vessel on her own port side. This has nothing to do with the interpretation of Rule 10(j).

In conclusion, I would agree with Pat Manley that an additional visual signal for vessels less than 20 metres is not required, but I am sure it would be helpful if more mariners shared the above understanding of 'not to impede.'

ACKNOWLEDGEMENT

T. J. Williams, Extra Master Mariner, for his help and advice.

REFERENCES

- Cockcroft, A. N. and Lameijer, J. N. F. (1996). *A guide to the collision avoidance rules*, 5th Ed. Butterworth-Heinemann.
- Cooper, R. W. (2001). Removal of an ambiguity from the maritime collision regulations. *This Journal* **54**, 479.
- Manley, P. (2002). Collision Regulations – Discussion. *This Journal* **55**, 146.
- MGN 28. *Observance of Traffic Separation Schemes*.

DOI: 10.1017/S0373463302232026

Collision Regulations Discussions

Carlos F. Salinas

KEY WORDS

1. COLREGS.
2. Traffic Separation Schemes.
3. Marine collision avoidance.

The following article tries to shed light on the problem presented by R. W. Cooper (2001) in his article 'Removal of Ambiguity from the Maritime Collision

Regulations', and the later comments by P. Manley (2002). To sum up, it tries to present the doubt that may arise to an officer on watch of a large vessel following a traffic lane in a Traffic Separation Scheme (TSS) when a small vessel appears crossing from starboard, the doubt being created by the difficulty in determining whether the vessel is smaller or bigger than 20 metres in length. In the case that she is less than 20 metres in length, she must *not impede the safe passage* of the vessel in the TSS, otherwise, if she is more than 20 metres in length, the vessel in the TSS must *keep out of the way* because Rule 10 does not relieve this obligation under any other rule and this is a crossing situation (Rule 15).

In order to find a solution, I would like to focus on the differences between the concepts *not impede the safe passage* and *keep out of the way*, because they are not synonymous. Specifically:

- (a) *Not to impede the safe passage* is applied in any visibility conditions while *keep out of the way* can only be applied when the vessels are in sight of one another.
- (b) *Not impede the safe passage* tries to prevent risk of collision situations occurring whereas *keep out of the way* is an action that must be carried out when a risk exists.
- (c) The concept *not impede the safe passage* has more to do with the idea of leaving enough sea room to a power-driven vessel, generally bigger, and therefore with more difficulty to manoeuvre and change its route, while *keep out of the way* makes reference to an escape manoeuvre of the give-way vessel and the obligation of the stand-on vessel to keep her course and speed.

So graphically, we have two areas, the outer one that shows the beginning of the requirement of the small vessel so as not to impede the safe passage of the larger one, and a inner one that shows when a risk of collision starts (see Figure 1).

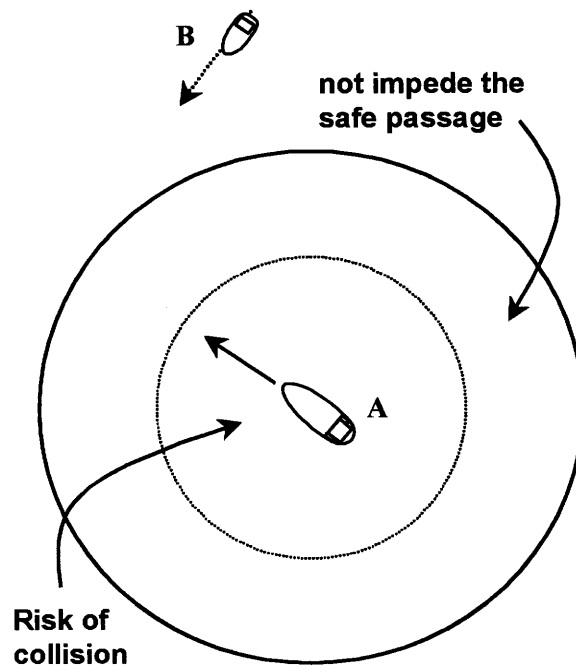

Figure 1. Domains.

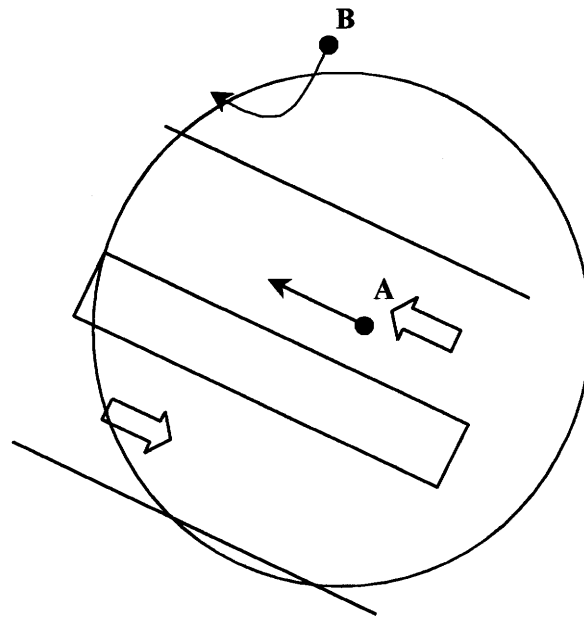

Figure 2. Possibility One.

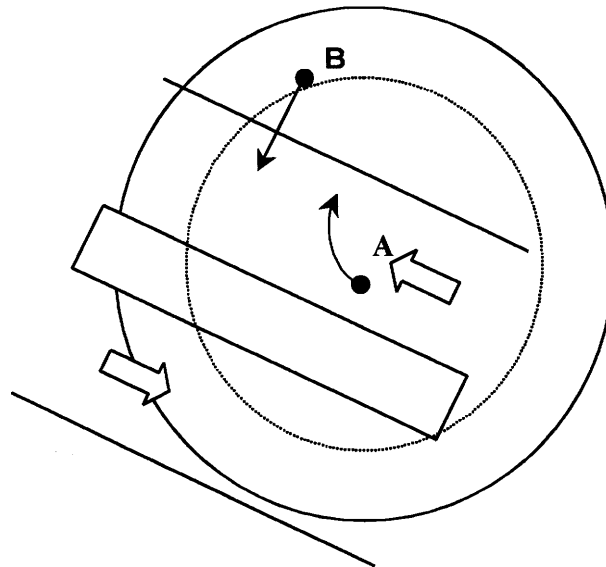

Figure 3. Possibility Two.

Possibility One: the small vessel is less than 20 metres in length. According to Rule 10 (j) and Rule 8 (f), in due time and before the risk of collision arises, she must *not impede the safe passage* of the large vessel, letting the other one pass (see Figure 2).

Possibility Two: the small vessel is less than 20 metres in length but she impedes the safe passage of the large one and a risk of collision arises. In this case, the large vessel

must *keep out of the way* of the small one because it is a crossing situation and the officer on watch must comply with Rule 8 (f) (iii). The small vessel is not relieved of her former obligation and can be reported to the maritime authorities, but what must be highlighted is that the COLREG's philosophy is only interested in preventing a collision, so there is always one moment where the vessel that thinks she has a right of way must manoeuvre. There is no instance in any of the COLREGs where a vessel could think that she has nothing to do (see Figure 3).

Possibility Three: the small vessel is larger than 20 metres in length. So, the vessels are involved in a crossing situation, where the one that navigates along the traffic lane must *keep out of the way* of the one which is crossing. The crossing one must keep her course and speed. There is no area associated with *not to impede the safe passage*, because it does not apply in this specific case (see Figure 4).

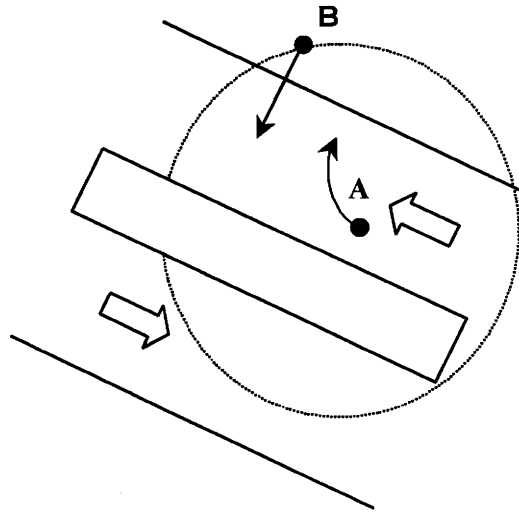

Figure 4. Possibility Three.

As we can see, at the end, if a risk of collision arises (possibilities two and three) the large vessel must manoeuvre. So in theory, the ambiguity does not exist, although we must accept that in practice, the situation is more complicated because everything takes place in a very short period of time, with possibly high traffic density and little sea room to manoeuvre.

With reference to the proposed solution of increasing the criterion of 20 metres in length to 30 metres, I agree that it would only transfer the problem up the scale size. Furthermore, I do not think that the concept of requiring some form of visual signal would be practical. Based on the experience acquired in different presentations of similar cases in specific seminars with experienced captains and pilots, I propose something much more extreme, but possibly more effective: to give the privilege of way to the vessel that navigates along a traffic lane. The manoeuvring effort of the crossing vessel is usually minimum. It could be alleged that in some traffic lanes, we are inducing the crossing vessel to manoeuvre to port seeking the stern of the other,

and we know that any port alteration can be a problem, but what if, in this case, the crossing vessel reduces her speed so letting the other pass?

REFERENCES

- Cooper, R. W. (2001). Removal of an ambiguity from the maritime collision regulations. *This Journal*, **54**, 479.
- Manley, P. (2002). Collision Regulations – Discussion. *This Journal*, **55**, 146.