

Elite Polarization Meets Mass Moderation in Mexico's 2006 Elections

Even before the 2006 presidential election dissolved into a nasty street battle, it was widely perceived as strongly polarized. The two leading candidates, Felipe Calderón of the conservative National Action Party (PAN) and Andrés Manuel López Obrador of the leftwing Party of the Democratic Revolution (PRD), staked out starkly different positions on key economic issues. Calderón promised continuity with Mexico's free-market reforms, focusing on investment as the engine of growth. López Obrador, in contrast, argued that the neoliberal strategy would benefit only a few and he instead promised to alleviate poverty through state spending on infrastructure and social welfare. Unlike in prior presidential elections where the PAN and PRD candidates downplayed their differences to challenge the authoritarian dominant PRI with broad pro-democracy appeals, in this first post-transition election, the candidates made their differences clear.

by
Kathleen Bruhn,
University of California,
Santa Barbara
Kenneth F. Greene,
University of Texas at Austin

Even the most polarized campaigns typically yield to institutionalized opposition after Election Day. But in this case, the razor-thin, under 0.6% margin of victory for Calderón cast doubt on the outcome and led to increasing polarization

in the post-election period. On Election Night, both Calderón and López Obrador confidently announced victory. López Obrador then escalated his confrontation with the state well beyond what most observers expected—from marches and blockades of major thoroughfares, to efforts to paralyze Congress and plans to establish a parallel government (see Todd Eisenstadt's contribution to this symposium). Even more remarkable was the ease with which López Obrador secured the loyal support of top PRD leaders and the active participation in protests of hundreds of thousands of Mexican citizens.

Nevertheless, the chain of events unleashed by the protagonists in this tragic drama may not accurately reflect the extent to which ideological polarization in Mexico extends to the broader political elite, much less to the voters themselves. In this brief article, we explore how deep the polarization goes. Does it begin and end with the presidential candidates, does

it extend to the main parties' congressional candidates, or does it run still deeper to the voters?

If polarization extends from the top of the political system to the bottom, then the virtual tie between López Obrador and Calderón reflects opposing mandates of equal weight that are unlikely to vanish quickly. The lack of consensus would make it difficult to govern not only during the current legislative period but well into the future as these two political blocs consolidate. However, if the polarized campaign was manufactured by elites alone, without a deeply divided public, then the current political crisis may be more temporary and compromise in Congress could emerge over time.

In what follows, we describe the issue differences between congressional candidates and voters on several of the most salient policy questions confronting Mexico. We also provide a first assessment of the likely extent of policy representation and whether political elites are disposed to "stand for" their constituents in accord with a mandate or "act for" the voters as trustees with their own distinct agendas (Pitkin 1967). Our findings suggest that ideological polarization goes well beyond the polemical campaigns of the presidential candidates, but remains mostly confined at this point to political elites. This combination of polarized elites and moderate voters implies that Mexico has not undergone a deep partisan realignment, that voters were surprisingly immune to campaigns that attempted to draw them into partisan battles, and that post-electoral protests may have difficulty engaging more than a limited group of partisans.

Our Data: Candidate and Voter Surveys

In addition to the Mexico 2006 Panel Study of voters that is the basis for other contributions to this symposium and described elsewhere (see Klesner's introduction to the symposium), we base our analysis on the Mexico 2006 Candidate and Party Leader Survey, conducted in the three weeks prior to the election.¹ Here we examine the responses of congressional candidates for single-member districts. Mexico has a mixed electoral system, with 300 majority districts and 200

proportional representation seats for the lower house. We focused on the majority-district candidates for two reasons. First, these candidates were much more likely to campaign locally and to be aware of voter responses than their counterparts from the party lists, who were virtually hidden from the voters. Second, district candidates account for the majority of congressional seats. They may take a back seat on the party bench to the top list candidates who are hand-picked by the party leadership, but they will determine the success of legislative bargaining in Congress.

Our original intent was to include all three major parties; however, the PRI declined to provide us with the necessary contact information. The survey therefore includes only candidates from the PAN and the PRD-dominated Coalition for the Good of All. Yet the dataset serves our purposes nicely because it contains responses from the two largest and most ideologically distinct parties. Thus, these data should give us a good picture of the extent of polarization at the elite level. Our telephone sample includes 84 responses from PAN candidates and 77 from PRD candidates.²

Since we both participated in the design of the voter and candidate surveys, our analysis has one significant advantage in comparing elite and mass opinion. Unlike the best-known existing comparisons (Miller and Stokes 1963), we were able to use the same question wording for both types of respondents and apply the surveys at roughly the same time. Although words may not always have the same conceptual significance to both candidates and voters (Powell 2004), the correspondence between the elite and mass surveys enhances the validity of our comparisons.

Finally, in examining candidate-voter alignments we opted to look at national or “collective” rather than district or “dyadic” representation. Central party committees in Mexico exert substantial control over candidates due to the party list system and the prohibition against reelection that makes candidates reliant on party leadership for successive nominations. As a result, as in many European countries, the parties are highly disciplined.³ Following prior work by Barnes (1977), Dalton (1985), Converse and Pierce (1986), and others, we thus examine the mean preferences of candidates and various groups of voters with the idea that proximity in policy preferences underpins citizen influence in democratic politics.

Polarized Congressional Candidates

Congressional candidates from both parties agree on the key problems facing Mexico. When we asked them to name the most important problem, they spontaneously identified “jobs and unemployment” most frequently, followed by “crime and public security.” PRD candidates were more likely to name poverty first, but poverty was still the fourth most frequently cited problem among PAN candidates. Another open-ended question asked candidates to identify the theme they personally emphasized in their congressional campaigns. Again, candidates from both parties named jobs and employment as their principal focus, followed by education, health, and social spending.

Consensus about Mexico’s major problems is where agreement ends. The candidates disagreed so substantially about solutions that they represent distinct world views. When we asked whether the government or individuals should be responsible for citizens’ personal economic welfare, 75% of PAN candidates opted for personal responsibility while 68% of PRD candidates stated that the government should be partly or even fully responsible for citizens’ welfare. This substantively large difference was, unsurprisingly, statistically significant ($t = 5.8$, $p < .001$, two-tailed test).

A question about the appropriate size of government generated fascinating responses. We took a risk by constructing a potentially double-barreled question in the attempt to force a tradeoff. Specifically, we asked if candidates preferred a government with fewer services and lower taxes or one with more services and higher taxes. Fifty-six percent of PAN candidates opted for a smaller government compared to just 11.7% of PRD candidates. However, only 40% of the PRD candidates openly chose the bigger state/more taxes option. Instead, a high percentage (48.1%) apparently insisted to survey interviewers that they wanted lower taxes *and* more services. In part, their position may simply reflect the official position of their presidential candidate: that he could pay for all his new social programs by cutting government waste. Yet the spontaneous refusal to recognize a tradeoff between spending and taxing despite question wording designed to straightjacket their answers gives us strong evidence of their economic policy leanings. It is also, of course, precisely what had the PAN as well as many domestic and international capital-holders so worried about a López Obrador presidency.

On the critical question of commercial relations with the United States, differences were less stark. Virtually all PAN (95%) candidates preferred expanding commercial ties. Despite rhetoric at the level of the national PRD campaign that NAFTA should be cut back or renegotiated in some areas, only 22% of the party’s congressional candidates wanted to maintain commercial ties at current levels or reduce them. While significantly⁴ distinct from the PAN’s view, this finding suggests important limits on the PRD’s leftism (especially when compared to some of their South American counterparts), as well as broad recognition among elites that Mexico’s economic performance depends heavily on continued integration with the United States.

Important differences also emerged over the question of political openness. PAN candidates were significantly more likely to respond that “Mexico today *is* a democracy,” to anticipate that elections in their district would be clean, and to express confidence in the administrator of federal elections, the Federal Electoral Institute (IFE).⁵ PRD candidates perceived that Mexico was less democratic and its elections less fair. These pre-election judgments not only help explain PRD support for López Obrador’s quixotic campaign and aggressive post-election protest, but also suggest differences between the two parties in their levels of political trust and belief in Mexico’s transition to democracy.

For two questions—on abortion and on privatization of the electricity sector—we asked respondents to locate not only their own personal position, but also that of their rival party. These placements appear in Figure 1. The average personal preferences of each party’s candidates along the top show that PRD candidates are pro-choice and oppose privatization while PAN candidates line-up on the opposite side as pro-life and in favor of privatization.

Along the bottom of each chart, we arrayed the PAN’s perception of the PRD’s issue positions and the PRD’s perception of the PAN’s. These views show some projection of polarization beyond what actually exists; however, this projection appears somewhat smaller than observers of Mexican politics might expect. In-depth interviews often suggest that rival candidates believe their opponent’s beliefs are extreme to a point that stretches credibility. Our data show that despite some projection that could complicate good faith negotiations in Congress, the perceptions are not so outlandish that the two delegations should be unable to communicate. The data essentially show agreement about disagreement: despite large differences on the issues, the rival candidates understand the magnitude of their differences.

Figure 1
Candidate Preferences on Electricity Privatization and Abortion⁶

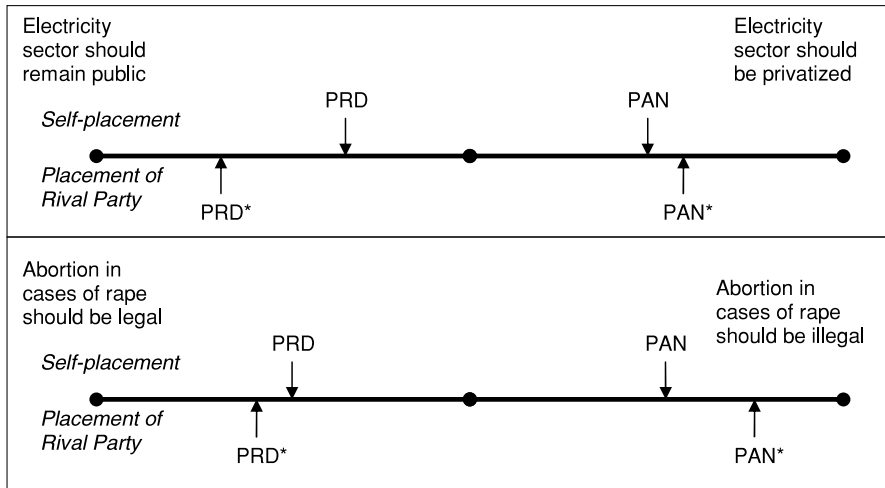

N = 84 for PAN and 77 for PRD.

This evidence indicates that ideological polarization extends beyond the presidential candidates to, at least, congressional candidates in the PAN and the PRD. These legislative candidates are, it turns out, mostly drawn from local political elites. In both parties, candidates had resided in their districts for about 30 years on average and were more likely to have served as municipal or state party leaders than national ones. As a result, the differences we document are not limited to a potentially insular Mexico City elite, but represent real, substantive, and widespread ideological differences between these two parties both nationally and locally.

Elite polarization on the issues should have sent clear cues to the voters, but did they respond? How clearly aligned are the parties' candidates with their core voters, with independents, and with the electorate in general? To examine these issues, we utilize the third wave of the Mexico 2006 Panel Study of voters, taken shortly after the election.

Moderate Voters⁷

The voters are, in general, more moderate on the issues than the candidates. As we would expect, the smallest differences appear between candidates and voters who identify with the same party; however, even in this case, the candidates are more extreme than their own core voters on the issues of privatization, abortion, and social welfare. When it comes to independents and the electorate as a whole, the candidates are substantially out-of-step. In this section, we replicate candidate positions from the analysis above but also place voters using data from the Mexico 2006 Panel Survey.⁸

On the question of privatization of the electricity sector, PAN and PRD candidates endorse very different positions, but the voters are clustered fairly close toward the center and against privatization (see Figure 2). This creates a strikingly large distance between PAN candidates who appear as radical privatizers out-of-tune with a tepid base. On this issue, PRD candidates hold beliefs much closer to those of the average voter, as well as to those of their own constituency.

A similar pattern appears on the issue of abortion in the case of rape. The PAN is closer to the voters in general, but finds

itself on the opposite side of the issue. Perhaps the biggest surprise is that PRD candidates are much more in favor of legality than their own core voters. While important for policy, these differences probably did not matter much in the election since the abortion question has never been as politically mobilized in Mexico as in the United States.

On the question of social welfare, PAN candidates are much more in favor of individual responsibility for citizens' social welfare than are their own constituents, who want some level of government assistance. The bigger surprise, however, is that PRD candidates are more in favor of government assistance than their core voters. We would typically expect voters to place more demands on government and for prospective legislators, knowing the real constraints on government spending, to hold back somewhat. Not only does this not appear to be the case, but the rightward skew in preferences suggests that Calderón's campaign for jobs may have resonated more broadly than López Obrador's call for poverty-alleviation.

A different pattern emerged over the question of commercial relations with the United States. As we noted above, PRD candidates were much less opposed to expanding economic ties with the United States than their national-level campaign rhetoric suggested. Unsurprisingly, PAN candidates were uniformly in favor. What we find more interesting is the much lower level of support by the voters. Even among PAN voters, often thought to draw from those who benefit from free trade, there is skepticism. PRD voters are the least supportive, as we would expect, since the PRD draws more voters from the ranks of the poor and those in the south who have benefited less from free trade. But it is notable that even these voters are more in favor of than opposed to expanding economic ties to the United States. These findings appear to cast doubt on the productiveness of López Obrador's campaign rhetoric, which was somewhat further to the left on this question.

We also explored prospective opinions about how clean respondents thought the July election would be when we interviewed the voters in May and the candidates in June. Figure 3 shows that in this instance, candidates were much closer to each other than were their parties' voters. PRI and PRD voters were the most skeptical that the elections would be clean, while PAN voters apparently trusted in the elections much more than the political elites they supported. The level of skepticism about clean elections needs to be underscored here, given that analysts roundly applauded the non-partisan IFE and Mexico as a shining example of how new democracies should run elections. Apparently, substantial segments of the political class and voters did not agree. The polarization among voters, coupled with the post-electoral mobilizations that have undoubtedly brought PRD candidates further to the left, indicate that the question of institutional reform will likely be an important political cleavage moving forward.

Finally, elite polarization and mass moderation was reflected in self-placements on the more abstract Left-Right scale as shown in Figure 4. As on the issues, candidates from the PRD place themselves on the left and those from the PAN place themselves on the right; they are not self-identified "centrists." In contrast, voter placements are more diffuse and spread across the Left-Right dimension. We make no claims about the particular meaning of "left" and "right" in these data and want to draw

Figure 2
Candidate and Voter Preferences on Four Major Issues⁹

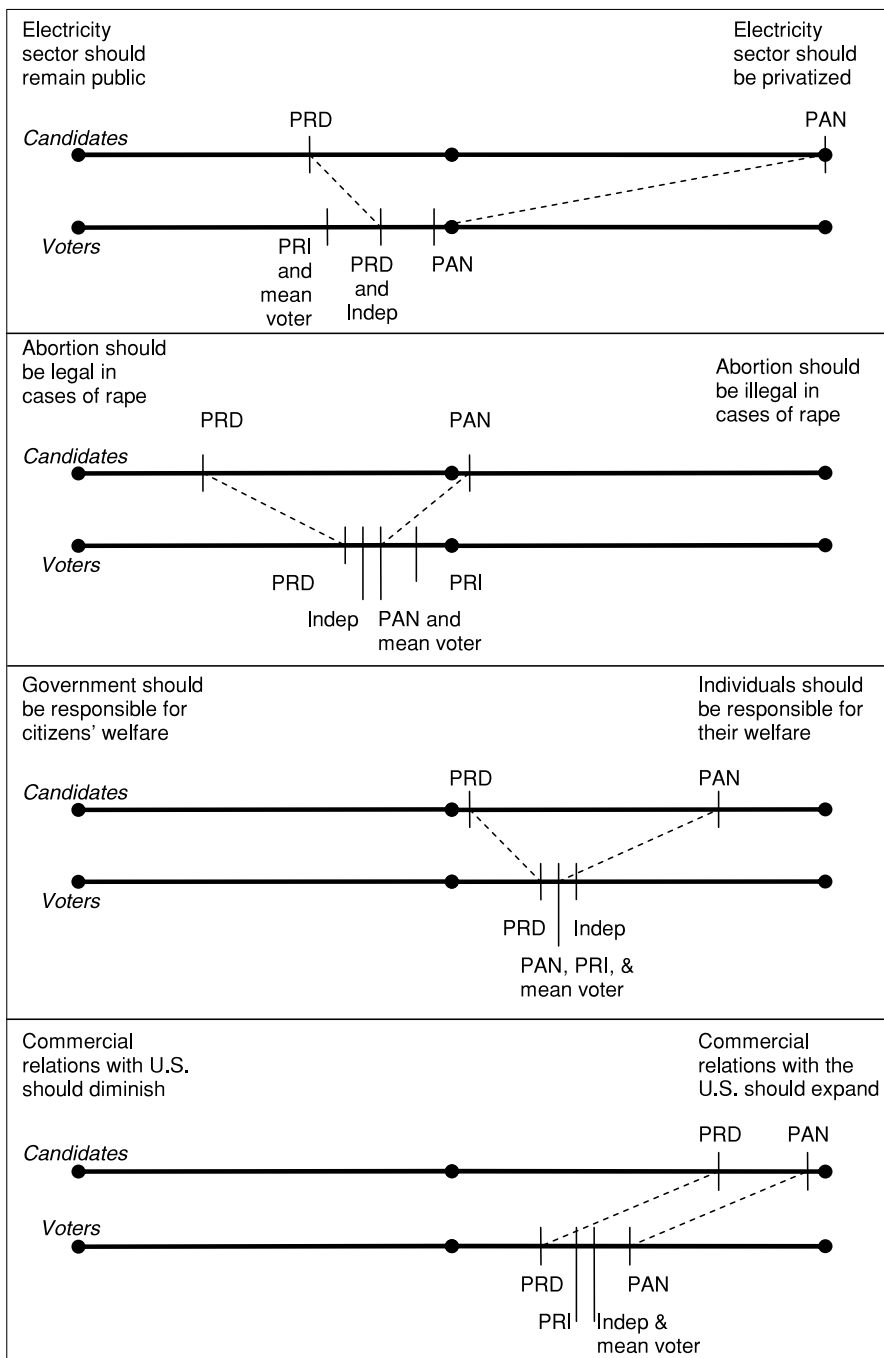

N = 84 for PAN candidates; 77 for PRD candidates; 303 PAN identifiers; 214 PRD identifiers; 310 independents; 1,049 all voters.

attention to the fact that 27.5% of voters either could not place themselves on the scale or responded that they had no position. Nevertheless, those who do identify a position are far less polarized than are candidates.

Conclusion

Our data demonstrate that there were strong ideological differences not only between the presidential candidates but also between elites in the respective parties. Candidates from the

PAN combine fiscal and social conservatism, much like Republicans in the United States. They are pro-life, favor privatization of the electricity sector and expanded commercial relations with the United States, and believe more in investment and individual responsibility to reduce poverty. PRD candidates sharply disagree on most of these issues. They are pro-choice, want to maintain public ownership over the strategic electricity sector, and endorse an expanded social safety net with greater government responsibility in providing for the poor. They are also somewhat more skeptical about the benefits of commercial ties with the United States, although this difference was much more muted than we expected. One might have expected these relatively clear positions to give voters strong signals that would help structure voting choices along ideological lines. Nevertheless, the picture at the mass level is more mixed. Party identifiers of the PRD and the PAN share some but not all of their differences with party elites and in general cluster quite closely around the average voter.

We draw three main conclusions from this examination of party-voter alignments. First, polarization is limited to the political elite and does not feed off of deep political divisions in the electorate. This finding implies that despite the important transition from authoritarian dominant party rule under the PRI to fully competitive democratic politics by 2000, Mexico has not undergone a major partisan realignment. It also implies that voters are, to this point, strikingly resilient to ideological overtures by the candidates who have tried and failed to “mobilize bias” on the most salient political issues. It appears that the issue content of partisan battles in Mexico’s democratic politics has not yet been set at the mass level.

Second, the type of representation in government we can expect from PAN and PRD candidates is one of “acting for” rather than “standing for.” Instead of striving to represent the average voter or act as “delegates” for their core voters, the PAN and PRD engage in what Kitschelt et al. (1999) referred to as “polarized trusteeship” by fostering legislation that leads rather than follows public opinion on the issues. This leaves us with the impression that such representatives are out-of-step with the electorate and in some sense seek to contravene the public

will. At the same time, representatives who legislate in this manner present voters with clear, easily distinguishable choices and may give voters the opportunity to “balance” the presidency with a Congress that seriously debates public policy choices, should they choose to think about politics in this way.

Finally, given the extent of their policy differences, the prospects for legislative collaboration between the PRD and PAN would have been quite limited under the best of circumstances, even without López Obrador’s intransigence. Those familiar with Latin American political history will remember

Figure 3 Candidate and Voter Beliefs about Electoral Fairness

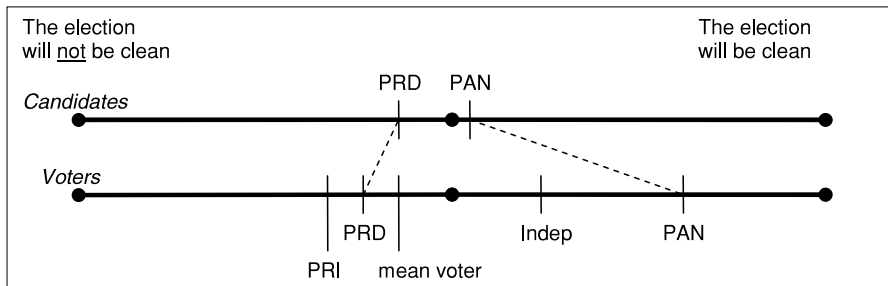

N = 84 for PAN candidates; 77 for PRD candidates; 303 PAN identifiers; 214 PRD identifiers; 310 independents; 1,049 all voters

Note: Differences in means test for PAN vs. PRD candidates: $t = 1.8, p < .1$ (two-tailed).

Figure 4 Candidate and Voter Positions on the Left-Right Dimension

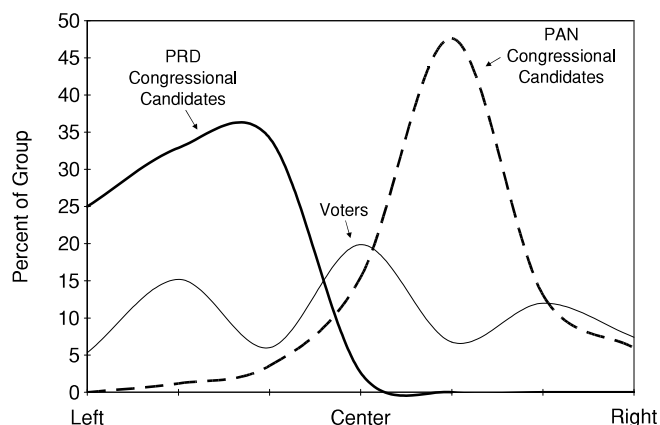

N = 84 for PAN candidates; 77 for PRD candidates; 1,049 for all voters

Note: Difference in means test for PAN vs. PRD candidates: $t = 18.9, p < .001$.

that legislative polarization was an important element in the breakdown of democracy in Brazil and Chile not so long ago. In addition, Bermeo (2003) has shown that elite polarization more often brings about the breakdown of democracy than polarization at the mass level, and Mainwaring (1993) has argued

that presidentialism with a multi-party legislature often leads to gridlock. Despite the warnings and the clear evidence of elite polarization in our data, we are cautiously optimistic about the prospects for legislative action for two reasons.

First, the correlation of forces in Congress and the weakened position of the PRI imply that we may see PAN-PRI alliances to construct legislative majorities. The dire predictions of prior literature place a great deal of emphasis on the centrist party's decision to cooperate with one of the more extreme parties or to block majorities. On many issues, the PRI occupies the middle position between the PRD and the PAN. The PRI's relatively large legislative delegation in the 2000–2003 and 2003–2006 legislatures raised hopes that the party's candidate could win the presidency in 2006 and discouraged

handing President Vicente Fox legislative victories (see the article by Joy Langston in this symposium). In the 2006–2009 legislature, the PAN will hold 41.2% of seats to the PRI's 20.8% and the PRD's 25.2%. The PRI may be desperate to rebuild and, anticipating that the PRD will not cooperate, it may see an opportunity to extract concessions by voting with the PAN and the president. The resulting PAN-PRI alliance would be sufficient to pass ordinary legislation even if the PRD votes as a bloc against it. Only constitutional reforms would be beyond the alliance. Legislators need not be responsive to voters in order for cooperation to occur, as long as PRI legislators are willing to trade cooperation for favors and resources. Early indications that the PRI will chair most of the key committees in the new Senate—despite having only 26% of the seats—suggest that some bargaining may already be occurring. If legislative bargaining fails, as it did on many of the most important initiatives during the Fox term, the reason will not be ideological polarization alone, but also political strategy.

Second, we find grounds for optimism in the lack of polarization among voters. To this point, voters have not been drawn into elite partisan battles. The potential for such polarization exists if voters outside of Mexico City become mobilized in favor of or against López Obrador's post-electoral protests. Alternatively, voters could rebel, declare a pox on both of their houses, and return to the centrist party that quietly waits out the storm in control of more Mexican governorships than any other party: the PRI. However, if voters remain as resilient to mobilization by comparatively extremist elites in the post-electoral period as they were during the campaigns themselves, future electoral behavior will remain as volatile as it has been in the past.

Notes

*The authors are listed in alphabetical order.

1. Co-Principal Investigators Kathleen Bruhn and Kenneth F. Greene. The project was funded by the University of Texas at Austin and the University of California, Santa Barbara. We split the sample into a telephone survey and a web survey, but we only report the results of the larger telephone survey here. The telephone survey was administered by Data OPM, Mexico City. The authors particularly want to thank Pablo Parás, Luis Estrada, and their intrepid survey team for carrying out this work as well as Chappell Lawson for important input on survey design.

2. Our contact lists for the telephone survey contained 176 PAN candidates and 166 PRD candidates. (Note that we held back 100 of the 300 PAN candidates for the web survey and the PRD list had many missing con-

tacts, principally for candidates from other parties that participated in the Coalition for the Good of All.) Based on our initial contact lists, our response rate was 47.7% for the PAN and 46.4% for the PRD. The uniqueness of our survey means that we lack comparative data; however, considering that the survey was administered in the hectic last days before the election, we consider our response rate to be quite good. Based on the universe of candidates for single-member district races in the lower house, our response rate is still quite respectable at 28% for the PAN and 25.7% for the PRD.

3. In addition, Weissberg (1978) showed that dyadic district-level comparisons can lead to incorrect inferences to national-level or "collective" representation.

4. $t = 3.5, p < .001$, two-tailed test.

5. On the question of democracy, $t = 3.3$, $p < .001$. For the expectation of clean elections, $t = 1.8$, $p < .1$ (two-tailed tests).

6. Difference of means test. For electricity privatization, self-placement, $t = 13.1$, $p < .001$; placement of rival $t = 17.6$, $p < .001$ (two-tailed tests). For abortion, self-placement $t = 5.4$, $p < .001$; placement of rival $t = 13.7$, $p < .001$ (two-tailed tests).

7. Senior Project Personnel in the Mexico 2006 Panel Study include (in alphabetical order): Andy Baker, Kathleen Bruhn, Roderic Camp, Wayne Cornelius, Jorge Domínguez, Kenneth Greene, Joseph Klesner, Chappell Lawson (Principal Investigator), Beatriz Magaloni, James McCann, Alejandro Moreno, Alejandro Poiré, and David Shirk. Funding for the study was provided by the National Science Foundation (SES-0517971) and *Reforma*

newspaper; fieldwork was conducted by *Reforma* newspaper's Polling and Research Team, under the direction of Alejandro Moreno.

8. While in the previous figure we used 10-point issue position scales for the candidates' position, in this figure we use three-point scales for both the candidates and the voters, since the longer scales were unavailable for the mass survey. As a result, there are some small differences in candidate placement in the two sections.

9. On privatization, differences in means test for PAN vs. PRD candidates $t = 13.1$, $p < .001$ (two-tailed). On abortion in cases of rape, differences in means test for PAN vs. PRD candidates $t = 5.4$, $p < .001$ (two-tailed). On social welfare, differences in means test for PAN vs. PRD candidates $t = 5.8$, $p < .001$ (two-tailed).

References

- Barnes, Samuel H. 1977. *Representation in Italy: Institutionalized Tradition and Electoral Choice*. Chicago: University of Chicago Press.
- Bermeo, Nancy. 2003. *Ordinary People in Extraordinary Times: The Citizenry and the Breakdown of Democracy*. Princeton: Princeton University Press.
- Converse, Phillip E., and Roy Pierce. 1986. *Political Representation in France*. Cambridge, MA: Harvard University Press.
- Dalton, Russell H. 1985. "Political Parties and Political Representation: Party Supporters and Party Elites in Nine Nations." *Comparative Political Studies* 18: 267–99.
- Eisenstadt, Todd A. 2007. "The Origins and Rationality of the 'Legal versus Legitimate' Dichotomy Invoked in Mexico's 2006 Post-Electoral Conflict." *PS: Political Science and Politics* 40 (January): 39–43.
- Kitschelt, H., Z. Mansfeldova, R. Markowski, and G. Toka. 1999. *Post-Communist Party Systems: Competition, Representation and Inter-Party Cooperation*. New York: Cambridge University Press.
- Klesner, Joseph L. 2007. "The 2006 Mexican Election and Its Aftermath: Editor's Introduction." *PS: Political Science and Politics* 40 (January): 27–32.
- Langston, Joy. 2007. "The PRI's 2006 Electoral Debacle." *PS: Political Science and Politics* 40 (January): 21–25.
- Mainwaring, Scott. 1993. "Presidentialism, Multipartyism, and Democracy: The Difficult Combination." *Comparative Political Studies* 26 (2): 198–228.
- Miller, Warren E., and Donald Stokes. 1963. "Constituency Influence in Congress." *American Political Science Review* 57: 165–77.
- Pitkin, H. F. 1967. *The Concept of Representation*. Berkeley: University of California Press.
- Powell, G. Bingham. 2004. "Political Representation in Comparative Politics." *Annual Review of Political Science* 7: 273–96.
- Weissberg, R. 1978. "Collective versus Dyadic Representation in Congress." *American Political Science Review* 72: 535–47.