

Infant Crying: Pattern of Weeping, Recognition of Emotion and Affective Reactions in Observers

Mariano Chóliz¹, Enrique G. Fernández-Abascal², and Francisco Martínez-Sánchez³

¹Universidad de Valencia (Spain)

²Universidad Nacional de Educación a Distancia (Spain)

³Universidad de Murcia (Spain)

This study has three objectives: a) to describe the main differences in the crying patterns produced by the three affective states most closely related to crying: fear, anger and pain; b) to study the adults' accuracy in the recognition of the affective states related to the infant's crying, and c) to analyze the emotional reaction that infant crying elicits in the observers. Results reveal that the main differences appear in the ocular activity and in the pattern of weeping. The infants maintain their eyes open during the crying produced by fear and anger, but in the case of crying provoked by painful stimuli, the eyes remain closed almost all the time. In regard to the pattern of weeping, the crying gradually increase in the case of anger, but the weeping reaches its maximum intensity practically from the beginning in the case of pain and fear. In spite of these differences, it is not easy to know the cause that produces crying in infants, especially in the case of fear or anger. Although observers can't recognize the cause of crying, the emotional reaction is greater when the baby cries in pain than when the baby cries because of fear or anger.

Keywords: infant crying, facial expression, emotion, anger, fear, pain.

Este trabajo tiene tres objetivos: a) describir las diferencias en el patrón de llanto provocado por tres emociones características del llanto: miedo, enfado y dolor; b) estudiar el grado de precisión que tienen los adultos para reconocer la emoción que ha provocado el llanto y c) analizar la reacción afectiva de los observadores ante el llanto de los bebés. Los resultados obtenidos ponen de manifiesto que las principales diferencias se presentan en la actividad ocular y en la dinámica del llanto. Así, cuando los bebés lloran a causa del enfado, o por miedo, permanecen con los ojos abiertos, mientras que los mantienen cerrados durante todo el tiempo en el caso del dolor. En lo que se refiere a la dinámica del llanto, la intensidad se va incrementando gradualmente en el caso del enfado, mientras que aparece en su máxima intensidad desde el primer momento en el caso del dolor y del miedo. Pese a ello, no es fácil reconocer qué emoción es la que está provocando el llanto, especialmente con el enfado y miedo. Sin embargo, aunque no sepan reconocer la causa del llanto, el dolor provoca una reacción afectiva más intensa en los adultos que el enfado o miedo.

Palabras clave: llanto infantil, expresión facial, emoción, ira, miedo, dolor.

This study was carried out by means of a research project established between the authors and the company Roche Diagnostics S.L.

Correspondence concerning this article should be addressed to Mariano Chóliz. Departamento de Psicología Básica, Universidad de Valencia. Blasco Ibáñez, 21. 46010-Valencia (Spain). Phone: +34-963864853. Fax: +34-963864822. E-mail: Mariano.Choliz@uv.es

Crying is a dynamic multimodal behavior. It is the main form of communication from birth, and involves characteristic vocalizations, facial expressions and limb movements that can vary considerably over time. The human infant's predisposition toward increased crying might be adaptive, by promoting the child's survival when it requires the parents' aid. (Lummaa, Vuorisalo, Bard, & Lehtonen, 1998). It is a communicative sign that evolved to reduce the risk of parents failing to care for their offspring (Soltis, 2004). However, crying is also a stressor (McLaughlin, Hull, Edwards, Cramer, & Dewey, 1993), and the excessive crying of an infant can be one of the most trying aspects of parenthood (Long & Johnson, 2001).

Crying is the infant's main way to express negative emotions. Before the child acquires characteristic forms of expression for each of the possible emotions and a linguistic repertoire that allows him to precisely define his emotional state, crying is the most common and generalized way to express negative emotions. Infants cry when they feel discomfort or when they are angry, sad or afraid. Infant crying is a call for help from the caregivers, as many times the crying is the result of problems that the infant cannot easily resolve by him- or herself. Crying elicits parental responses in different mammals (Newman, 2007), and produces a negative emotional reaction in adults that only disappears once the child calms down (Barr, 2006).

Several decades ago it was suggested that newborns could cry in different ways depending on what caused the crying (Wolff, 1969). In the case of pain, it was proposed that facial expression of pain is universal in nature (Prkachin, 1992) and that it is more consistent in infants than in adults (Craig, Prkachin, & Grunau, 2001) because the infant's ability to express pain is crucial to ensuring his or her survival (Williams, 2002). Crying in infancy has been considered as a highly adaptive behavior, evolved to alert the environment and to elicit nurturing and close physical proximity to the caregiver (Zeifman, 2001). The sound of the cry conveys a sense of urgency, and triggers a physiological arousal in parents that prepares them to respond and reduce the infant's distress (e.g. Del Vecchio, Walter, & O'Leary, 2009). Thus, mammalian mothers respond with varying degrees of urgency depending on specific acoustic properties, such as the fundamental frequency (Protopapas & Lieberman, 1997; Soltis, 2004) or dysphonic cry (Cecchini, Lai, & Langher, 2010).

In the cry-face, the brows are lowered and the lip corners are pulled to the side (Messinger, 2002). Cry-face expressions involving cheek raising and mouth opening are associated with intense negative emotions (Fox & Davidson, 1988). In fact, more exaggerated cry-faces are perceived as more emotionally intense (Messinger, 2002). In the case of pain, the acoustic features of crying are useful to

distinguish among different degrees of pain (Bellieni, Sisto, Cordelli, & Buonocore, 2004). The duration also provides the caregiver with information, warning him/her in the case of abnormal patterns in the same way the rhythm of the crying does (Leeds & Thompson, 2005). Nevertheless, the cries produced by different emotions are hardly recognized by untrained judges (Oster, Hegley, & Nagel, 1992). The fact that the child cries in very different circumstances, which in turn require different responses from the caregivers, leads to various important questions: a) is there a different pattern of crying depending on the emotion that causes it?, b) is it possible for the person observing the weeping to distinguish the cause of the crying?, c) regardless of the degree of precision in recognizing the crying, do the different types of crying elicit different reactions in those who observe them?

This study has three objectives. The first is to describe the main differences in the weeping produced by the three affective states most closely related to infant crying: fear, anger and pain. The second is to analyze the adults' accuracy in recognizing the affective states related to the infant's crying, and the possible relevance of some of the main variables responsible for recognizing emotions, such as the contextual information. Finally, the third objective is to analyze the emotional reaction of the adults when they observe the infant weeping, and whether this reaction is different depending on the cause of the crying (fear, anger or pain).

STUDY 1

The objective of Study 1 was to analyze the facial and vocal characteristics of crying produced by acute pain, fear or anger. The main hypothesis is that each emotion elicits a type of weeping that is characterized by some specific facial or vocal expressions.

Method

Participants

The sample was composed of 20 infants (10 girls and 10 boys), aged between 3 and 18 months, whose crying was filmed and recorded in two natural contexts (day care and medical center). The sample was divided into two groups: 10 infants less than 8 months old and 10 infants older than 8 months of age. The reason for dividing the sample into these two age groups is that 8 months is a critical age in the process of interpersonal communication. From that age on, the infant clearly identifies the people with whom he/she has an intimate relationship, and shows separation anxiety and fear of strangers (Ainsworth, Blehar, Waters, & Wall, 1978).

In every case, consent was obtained from the parents, the person in charge of the center where the study was carried out, and the Child Protection Authorities.

Instruments

The taping was done by a professional team. The recording of the video sequences of the infants was performed with Betacam Digital quality. The files were recorded digitally using a unidirectional microphone in the AIFF standard, which is a compressed format without any loss, with a sampling frequency of 44.1 kHz and 16 bits of precision.

For the analysis of the facial expressions, the *Facial Action Coding System* (FACS) (Ekman, Friesen, & Hager, 2002) was adapted for infants (Fernández-Abascal, Martínez-Sánchez, & Chóliz, 2009). However, the eye and mouth areas received special attention and analysis.

Procedure

In order to elicit each of the affective states in the infants, the following procedure was used: 1) anger was provoked by holding their hands or feet for a few seconds, keeping them from moving these limbs until they became angry and cried; 2) fear was produced by means of an unexpected noise (clapping, object falling on the floor) outside the visual field of the infant, which produced fear and then crying; 3) pain was caused by the obligatory vaccination.

Pacifiers (dummies) were not used, and the infants cried for a few seconds before calming them.

As in Zeskind, Marshall, and Goff (1996), the first ten seconds of crying were selected because several acoustic features of infants' cries change during the course of a relatively long crying bout (Green, Gustafson, & McGuie, 1998), and because as time passes, different emotions can occur simultaneously (pain and fear, for example). This latter situation makes it difficult to identify the characteristic crying pattern of each emotion.

During the period in which they were crying, a professional team filmed the infant's face and taped the sound. The analysis took place during the first ten seconds of crying, and the activity of the muscles involved was studied using the FACS in order to select the sequences of

crying. Later, two kinds of measures were selected for the analysis: the activity of the ocular area, and the intensity of the crying:

a) Ocular area: Percentage of time that the eyes are closed during the crying.

b) Sound. Two parameters were analyzed: 1) latency of crying (in seconds) since stimulus (injection, noise or immobilization) was produced; and 2) progress of the intensity (in dB) of crying.

We have selected a type of analysis of the crying that was easily interpretable by the observers. This is not an acoustic analysis, strictly speaking, because we have analyzed only the intensity (in decibels) and latency of the crying. Nevertheless, the mean latency of crying is used in some studies of infant crying (Cecchini, Lai, & Langher, 2007; Robb, Crowell, Dunn-Rankin, & Tinsley, 2007), in order to study the response of nociceptive stimuli in infants (Delevati & Bergamasco, 1999) or as a diagnostic method (Rautava et al., 2007; Robb et al., 2007).

Results

The muscular activity of the face was a prototypical expression of crying in all cases, characterized by high tension in the forehead, eyebrows or lips, mouth opening and cheek raising. Analyses were performed based on the two age groups (younger and older than 8 months of age). The two most relevant parameters in which differences were obtained were: a) the time between the stimulus and the onset of crying; and b) the time the infants kept their eyes closed while crying. No statistical differences were found between younger and older infants. Results appear in Table 1.

Regarding the emotions that caused the crying (see Table 1), statistical differences were obtained between pain and fear in these parameters: a) starting to cry after the stimulus ($F(1, 18) = 37.4; p < .01$) and b) eyes closed during crying ($F(1, 18) = 10.7; p < .01$). There were also differences between pain and anger in the same parameters: starting to cry ($F(1, 19) = 20.2; p < .01$) and eyes closed ($F(1, 19) = 21.0; p < .01$). No differences were found between fear and anger. No differences were found in the maximum of intensity (in dB) between fear, anger and pain. Figure 1 shows these results graphically.

Table 1

Results obtained in several parameters of crying according to age. Mean and Standard Deviation

Emotion	Starting to cry after stimulus (sec)			Eyes closed during crying (sec)		
	Infant <8 months	Infant <8 months	Total	Infant <8 months	Infant <8 months	Total
Pain	1.75 (.96)	1.13 (.35)	1.3 (.7)	9.2 (.84)	8.13 (3.23)	8.5 (2.6)
Fear	6.50 (2.12)	9.75 (4.79)	6.7 (4.2)	6.50 (2.12)	3.80 (2.59)	4.6 (2.6)
Anger	8.20 (5.02)	9.00 (6.98)	8.6 (5.6)	4.60 (3.27)	2.57 (2.30)	3.8 (3.0)

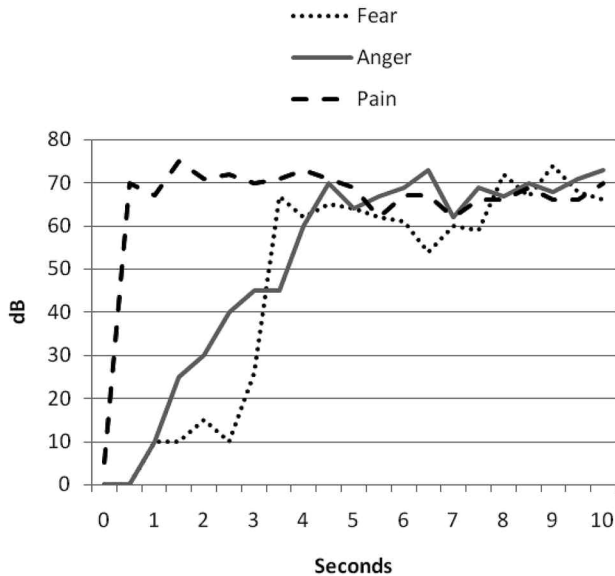

Figure 1. Crying pattern.

The types of patterns of crying caused by pain, fear or anger are described below and shown in the following photographs.

Anger

In most cases, the eyes are half-closed, with an apparently undirected look, or with a fixed and prominent look. The mouth is open, or half-open, and the intensity of crying is progressively increasing.

Fear

The eyes remain open almost all the time. Sometimes they have a searching look and move their heads back. The crying appears in an explosive way, after a gradual increase in tension.

Pain

The eyes remain closed almost all the time, and in the few moments when the eyes are open, the opening is minimal and the look distant. Other characteristics of the expression are a high degree of tension in the entire ocular area and a furrowed brow. The crying begins suddenly and immediately after the prick, and reaches its maximum intensity from the beginning.

Discussion

In this study, the crying that appears in response to fear, anger or pain shows some differences that can be recognized



Figure 2. Crying provoked by anger in infants younger and older than 8 months.



Figure 3. Crying caused by fear in infants younger and older than 8 months.



Figure 4. Crying elicited by pain in infants younger and older than 8 months.

through posterior analysis of the facial gestures and the crying itself. The main differences are the following:

With regard to the facial expression, the main difference appears in the ocular activity. The infants maintain their eyes open during the crying produced by fear and anger, but in the case of crying provoked by painful stimuli, the eyes remain closed almost all the time. The ocular tension is great, with the eyes tightly closed and a pronounced tension between the eyebrows. In the case of fear, after they have been given a scare, the infants keep their eyes open and look around. Finally, when they are angry, the ocular opening is less (around 50%), and they sometimes stare at the person who caused the discomfort. These differences in the ocular pattern could be due to the fact

that, whereas in the cases of fear and anger the threat that produces the discomfort is external, in the case of pain the problem is internal. Moreover, pain is a symptom of illness that urgently requires a response by the parents. In the case of fear, when the infants are afraid they look for help; when they are angry, they try to separate themselves from the situation that produced this emotion. However, these tentative hypotheses should be confirmed in future studies.

With regard to the dynamic of crying over time, differences can also be identified by means of the visual observation of the gestures and by listening to the crying. In the case of anger, the gestures and the crying gradually increase and become more intense, probably because the infants' frustration is also greater when their limbs are immobilized. Fear, however, reaches its maximum intensity practically from the beginning, due to the scare. Nevertheless, there is usually a period of time between the noise that scared the infant and the crying, during which the tension progressively increases until the infant begins to cry. Pain, once again, is usually different, because the crying appears at its maximum intensity from the beginning, and continues while the painful sensation lasts.

STUDY 2

The purpose of Study 2 was to analyze the emotion recognition of crying. The first step is to discover whether there are differences in the accuracy of emotion recognition among the three kinds of crying. The second is to analyze whether the context information (knowing what has provoked the crying) has an influence on the accuracy of the emotion recognition of crying. The main hypotheses are that the different patterns of cries can be distinguished by the observers, and that the context information optimizes the accuracy of recognition by the observers.

Method

Participants

The participants in the study were 306 adults (219 women and 87 men) from 18 to 67 years of age. All of them were students at one of three Spanish universities (Universidad de Valencia, Universidad de Murcia and the UNED).

These participants were divided into two groups, depending on the information they received before the task. The two groups were: a) the "Informed group" and b) the "Non-informed group". The "informed group" received brief information about the procedure that had been followed to obtain the sequences of infants crying (*see Procedure Section of Experiment 1*), while the "Non-informed group" was not told about these circumstances. This was the only difference between the two groups.

Instruments

The stimuli used in this study consisted of 38 video sequences of infants crying, pertaining to the tapes of the 20 infants from *Experiment 1*. The distribution of the crying sequences corresponded to 12 sequences of pain, 9 sequences of fear, and 17 sequences of anger.

The duration of the video sequences ranged from a minimum of 10 seconds to a maximum of 20 seconds. Any information about the context of the sequences was cut out, as well as information about the stimuli that had produced the crying, the professionals present, etc.

Procedure

The participants had a record sheet on which they had to write down the emotions the infants were experiencing when they were crying: 1: pain; 2: fear; 3: sadness; 4: anger and 5: other (which they had to specify in the space allocated for this).

Previously, the "Informed group" was told about the procedures followed to obtain the crying. The "Non-informed" group was not given any information about why the infant was crying.

The instructions given were the following: "*Next you are going to see several video sequences in which different crying infants appear. You must recognize why each one is crying:*

- *Because he/she feels pain*
- *Because he/she is afraid*
- *Because he/she is sad*
- *Because he/she is angry*
- *For any other reason (please, indicate what it is)"*

"*You must only indicate on the response sheet the option you choose after watching each of the sequences.*"

Next, the videos were shown, and the participants had to write down on the response sheet the emotion they thought had caused the crying in the infant.

Results

Table 2 shows the results obtained in the accuracy of identification (percentage of hits) of the emotion that provoked the crying (pain, fear and anger). Results obtained for both groups ("Informed group" vs. "Non-informed" group"), according to the two age groups (younger and older than 8 months of age), are shown in Table 2.

Discussion

As a general conclusion, we can indicate that it is not easy to distinguish the cause that produces crying in infants, especially in the case of fear or anger. Only pain is

Table 2
Accuracy of recognition of emotion of the infants younger and older than 8 months

Condition	Emotion that provoked crying	Rate of recognition (infant<8months)	Rate of recognition (infant<8months)	Rate of recognition Total
Non-informed	Pain	.40	.53*	.49
	Fear	.43	.36	.38
	Anger	.46	.39	.43
Informed	Pain	.60***	.67***	.64***
	Fear	.47	.37	.41
	Anger	.48	.46	.47

* Indicates differences at $p < .05$. Binomial test

*** Indicates differences at $p < .001$. Binomial test

recognized significantly well in infants older than 8 months. In the case of infants younger than 8 months, pain is recognized if information about the circumstances that provoked the cry (vaccination) is provided.

The relevance of the context was studied by analyzing the effect produced by the brief information about the procedure used on the accuracy of recognition. The information provided was only generic. Obviously, the participants did not know the reason for the crying in each specific case.

The information is especially significant in the case of pain and for infants younger than 8 months. In this case, when information about the procedure followed to induce the crying was provided, the recognition improved significantly. Nevertheless, this kind of information was not relevant in the case of fear or anger.

STUDY 3

The objective of the third experiment was to analyze the emotional reaction produced in the observer by the different types of infant crying analyzed in the two previous studies, that is, anger, fear and pain. The main hypothesis is that the different crying patterns will produce different affective reactions in the observers. Furthermore, given that pain is more related to adaptation and survival, this type of crying will produce the highest scores on the emotional reaction of the observers.

Method

Participants

In this experiment, there were 71 participants (60 women and 11 men) between 19 and 44 years of age, all of them psychology students from the University of Valencia.

Procedure

The participants viewed 38 video sequences of infants crying. After viewing each sequence, they were given time to indicate the emotional reaction it had produced in them.

The same video sequences were presented as in studies 1 and 2. The order of presentation was counter-balanced.

Instruments

Pleasure, arousal and dominance ratings were obtained by using the Self-Assessment Manikin (SAM) (Bradley & Lang, 1994, 2000; Lang, 1980). The SAM is a non-verbal pictorial assessment technique that directly measures the pleasure, arousal, and dominance associated with a person's affective reaction to a wide variety of stimuli. In this case, the objective is to measure the affective reaction produced by the crying. This instrument measures the three bipolar dimensions of emotion on a scale from 1 to 9 (see Figure

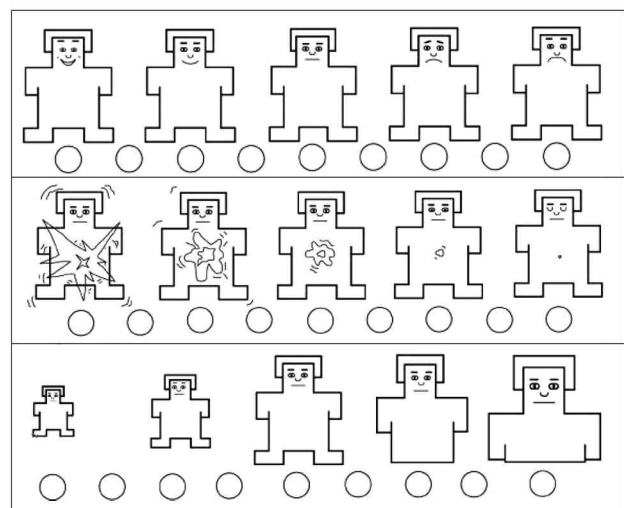

Figure 5. The Self-Assessment Manikin (SAM).

Table 3
Scores obtained by SAM in the observers of the infants

	Emotion	Mean	SD
Valence	Pain	3.06	.48
	Fear	3.40	.30
	Anger	3.79	.51
Arousal	Pain	5.61	.67
	Fear	4.74	.57
	Anger	4.66	.69
Dominance	Pain	4.98	.63
	Fear	5.73	.54
	Anger	5.80	.53

5). SAM has been used effectively to measure emotional responses to a variety of stimuli (Greenwald, Cook, & Lang, 1989; Miller, Levin, Kozak, Cook, McLean, & Lang, 1987; McNeil & Brunetti, 1992).

Results

Table 3 shows the scores obtained in each of the affective dimensions (pleasure, arousal and dominance) for each type of crying (caused by pain, fear or anger).

The following figures show the affective space of crying provoked by anger, fear and pain, respectively.

Valence

The scores for the three types of crying range from pleasantness to unpleasantness. The crying caused by pain is the one that produces a greater reaction of unpleasantness. Differences are statistically significant from the scores obtained by fear ($t = 3.83; p < .01$) or anger ($t = 10.03; p < .01$). Likewise, fear also produces a greater reaction of unpleasantness than anger does ($t = 4.72; p < .01$).

Arousal

In this case, the scores were found to lie in the central area, ranging between 5.61 for pain (closer to “nervousness”) and 4.66 for anger (practically the middle score). Crying produced by pain produced the greatest reaction of nervousness, with statistically significant differences compared to fear ($t = 10.11; p < .01$) or anger ($t = 13.91; p < .01$). There were no statistically significant differences between fear and anger in this dimension.

Dominance

Again, in this case the scores were found in the central part, ranging between 4.99 for pain (right in the middle)

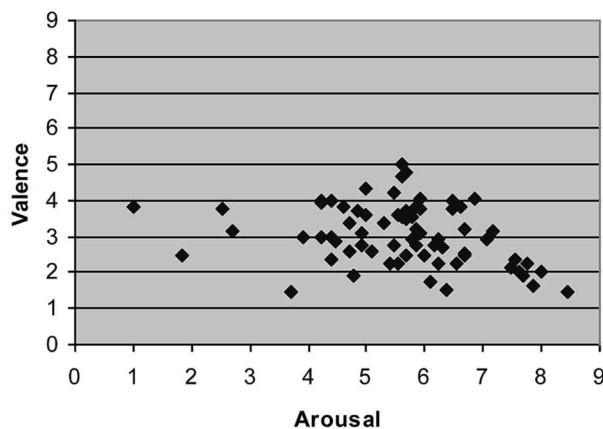

Figure 6. The affective space of crying: pain.

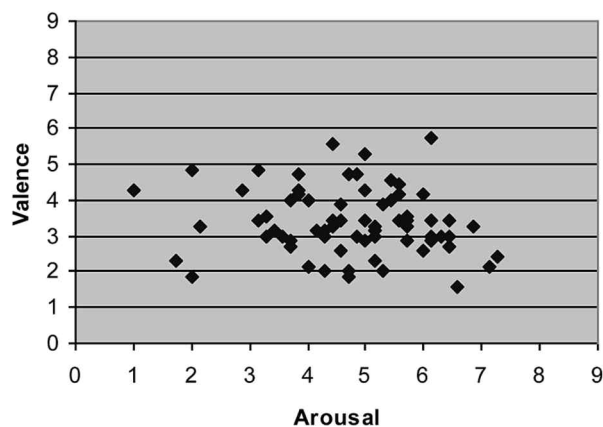

Figure 7. The affective space of crying: fear.

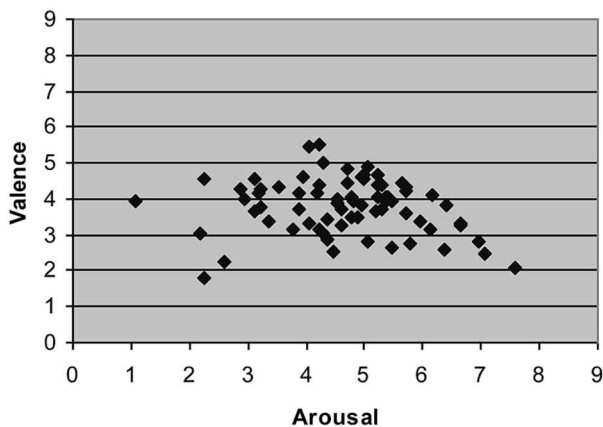

Figure 8. The affective space of crying: anger.

and 5.80 for anger (closer to “high control”). Crying caused by pain produced the greatest reaction of lack of control, with statistically significant differences compared to fear ($t = 8.11; p < .01$) or anger ($t = 8.68; p < .01$). There were no statistically significant differences found between fear and anger in this dimension either.

Table 4
Scores obtained by SAM in the observers of the infants younger and older than 8 months

	Emotion	<8months	>8months	<i>t</i>	<i>p</i>
Valence	Pain	3.27	2.94	3.70	.01
	Fear	3.61	3.32	-4.14	.01
	Anger	3.88	3.65	4.04	.01
Arousal	Pain	5.41	5.73	2.42	.01
	Fear	4.69	4.76	-.45	ns
	Anger	4.80	4.46	-.72	ns
Dominance	Pain	5.24	4.84	3.12	.01
	Fear	5.66	5.76	3.83	.01
	Anger	5.68	5.97	-3.53	.01

Finally, as in Studies 1 and 2, the sample was divided according to the age of the infants (< 8 months, and > 8 months), in order to find out whether there were differences between the emotional reactions caused by the infants in the observers. Results appear in Table 4.

In the case of pain, the older infants caused a higher emotional response, assessed by the SAM, than the younger infants did. There are significant differences in the three dimensions: the crying of the older infants elicits in the observer an emotional reaction that is more unpleasant ($t = 3.70; p < .01$), more intense ($t = 2.42; p < .01$), and less controllable ($t = 3.12; p < .01$), than the reaction elicited by the crying of the younger infants.

Discussion

One of the main functions of crying is to call for help from adults. This behavior is very useful because the crying causes an intense and disagreeable emotional reaction in the adult that disappears when the child stops crying. The causes for the infant's crying can be very diverse; therefore, the appropriate behaviors of adults in response to the weeping should also be different. For this reason, it seems relevant to study the affective reaction produced by the infant's crying, depending on the cause that caused it. The objective of the third experiment was to analyze the emotional reaction produced in the observers by the different types of infant crying analyzed in experiments 1 and 2 (anger, fear and pain).

The SAM analyzes the three main dimensions of emotional reactions (pleasantness, arousal and control). The results obtained indicate that the emotional reactions of the adults to the three types of infant crying show differences. Thus,

a) Crying caused by pain produced the highest levels of unpleasantness, arousal and lack of control. No differences were found between the crying caused by fear

and anger, except in the dimension of unpleasantness (scores for fear are higher than those for anger).

b) The emotional reaction produced by the crying is related to the urgency of the demands. Pain is the stimulus that causes the greatest discomfort in the observers because it has the greater salience and urgency. This reaction obviously has an adaptive and functional value.

c) The older infants elicit a greater emotional response in the observers. This result could be explained by the fact that in older infants crying is a reaction that is more specific to negative affective states, whereas for the younger infants or newborns, crying is the main form of expression, even for slightly negative emotions or neutral ones. Therefore, in the case of the older infants, the crying more clearly signifies an intense and negative affective emotion.

General Discussion

Crying is the main way for infants to express negative emotions. Infants cry indistinctly when they feel discomfort or when they are angry, sad or afraid. For this reason, it is very important to know if there are differences in the patterns of weeping produced by different emotions, and if these differences are detected by adult observers..

In the first place, it seems that it is possible to distinguish between different patterns of crying in infants by means of the analysis of facial expression and the sound emitted. With regard to the facial expression, the ocular area is the part of the face that provides the most information. Thus, while in the cases of fear and anger, the child maintains his or her eyes open, in the crying produced by pain, the infant's eyes are usually kept closed. When the infant does open his or her eyes, he or she does not look in any specific direction. On the other hand, it seems that when there is fear, the infant looks away from the threat and, in any case, toward an adult, as in seeking help. In this case, the expression is accompanied by tension in the

mouth area. In cases of anger, the infant looks at the person who causes the threat. However, experimental studies are needed to confirm these last two assumptions.

The sound dynamics are also different in the three cases. In the case of pain, the sound appears in an explosive way when the painful stimulus occurs. As found in other research, the latency time is short (Runefors & Arnbjörnsson, 2005), and the sound appears suddenly and with the greatest intensity from the beginning. In the case of fear, the crying also appears suddenly, but after a period of time in which there is an increase in tension that can be observed in the facial muscle tension. Finally, when crying is provoked by anger, the intensity of the weeping increases gradually and in a coordinated manner with the facial muscle tension.

Nevertheless, the fact that there are differences among these types of crying does not mean that they are perfectly recognizable by the observers. If one does not know what emotion elicits the crying, it is very difficult to identify the cause. This result is coherent with some studies in which only experienced people can recognize the type of crying (Irwin, 2003), and with other studies that demonstrate that the face of an infant at a few months of age expresses well being or distress, but it expresses discrete emotions less clearly (Galati & Lavelli, 1997). In this study, only pain is recognized well, and especially when the observers know the procedure used to produce the crying in the infants. The fact that pain is the most easily recognized emotion when it produces crying may have an adaptive explanation, as the crying is a warning of a potentially serious threat to health or survival.

Even though infant crying caused by fear and anger is not recognized accurately, it appears that it can cause different emotional reactions in the observers. Of the three emotions, pain presents a more intense and disagreeable emotional reaction, and it causes greater feelings of lack of control in the observers. These results seem congruent with the fact that pain requires a more urgent response by caregivers. Moreover, there were differences between fear and anger in the unpleasantness dimension, but not in the arousal and dominance dimensions.

Finally, it should be pointed out that, although the results obtained help to clarify the role of the emotions in infant crying and the reaction this crying produces in adults, there are some questions that remain unresolved and need to be studied more in detail. Perhaps the most significant is the difficulty of recognizing crying caused by fear, because it is also an emotion that requires immediate help from caregivers. Even though fear is not recognized very well, it is more disagreeable to the observers than anger. Later experimental analyses of facial and vocal expressions will make it possible to distinguish fear from other types of crying. Acoustic analysis is needed, because the adult that listens to the cry attributes to it greater or lesser urgency in relation to its physical-acoustic features. Cecchini, Lai, and Langher, (2010)

found positive correlations between dysphonic cry and attribution of anger/anguish to the newborn cries, and negative correlation between the percentage of silent expirations and attribution of anger/anguish.

Because of that the cries were different lengths, we selected only the first 10 seconds. Nevertheless, the mid and later portions of the crying episode (which can have even 30 seconds) reflect the infant's gradual control over the crying, and could be relevant in the analysis of the differences between different types of crying. In fact, Goberman and Robb (1999) found differences between pre-term and full-term infants once the entire crying episode was examined.

Another question that should be addressed is to analyze whether experience in caring for infants favors the recognition of crying. It is possible that experience modifies the cry perception, because parents appear to integrate information during the entire cry, whereas non-parents appear to focus on information at discrete points in the cry (Green, Jones, & Gustafson, 1987). Finally, another topic of great interest is whether there are differences between negligent parents and those who maintain healthy child-rearing habits or bonding, and the adult characteristics associated with different responses to infant distress (Zeifman, 2003).

References

- Ainsworth, M. D., Blehar, M. C., Waters, E., & Wall, S. (1978). *Patterns of attachment*. Hillsdale, NJ: Erlbaum.
- Barr, R. G. (2006). Crying behavior and its importance for psychosocial development in children. In R. E. Tremblay, R. G. Barr, & R. D. Peters (Eds.), *Encyclopedia on Early Childhood Development* [online]. Montreal, Quebec: Centre of Excellence for Early Childhood Development. Retrieved from http://www.child-encyclopedia.com/documents/Barr_ANGxp.pdf
- Belliemi, C. V., Sisto, R., Cordelli, D. M., & Buonocore, G. (2004). Cry features reflect pain intensity in term newborns: An alarm threshold. *Pediatric Research*, *55*, 142–146. <http://dx.doi.org/10.1203/01.PDR.0000099793.99608.CB>
- Bradley, M. M., & Lang, P. (1994). Measuring emotion: The self-assessment manikin and the semantic differential. *Journal of Behavioral Therapy and Experimental Psychiatry*, *25*, 49–59. [http://dx.doi.org/10.1016/0005-7916\(94\)90063-9](http://dx.doi.org/10.1016/0005-7916(94)90063-9)
- Bradley, M. M., & Lang, P. (2000). Affective reactions to acoustic stimuli. *Psychophysiology*, *37*, 204–215. <http://dx.doi.org/10.1111/1469-8986.3720204>
- Cecchini, M., Lai, C., & Langher, V. (2007). Communication and cry in newborns. *Infant, Behavior and Development*, *30*, 655–665. <http://dx.doi.org/10.1016/j.infbeh.2007.03.002>
- Cecchini, M., Lai, C., & Langher, V. (2010). Disphonic newborn cries allow prediction of their perceived meaning. *Infant, Behavior and Development*, *33*, 314–320. <http://dx.doi.org/10.1016/j.infbeh.2010.03.006>

- Craig, K. D., Prkachin, K. M., & Grunau, R. V. E. (2001). The facial expression of pain. In D. C. Turk & R. Melzack (Eds.), *Handbook of pain assessment* (2nd Ed., pp. 153-169). New York, NY: Guilford.
- Del Vecchio, T., Walter, A. L., & O'Leary, S. G. (2009). Affective and physiological factors predicting maternal response to infant crying. *Infant Behavior and Development*, *32*, 117-122. <http://dx.doi.org/10.1016/j.infbeh.2008.10.005>
- Delevati, N. M., & Bergamasco, N. H. P. (1999). Pain in the neonate: An analysis of facial movements and cry in response to nociceptive stimuli. *Infant Behavior and Development*, *22*, 137-143. [http://dx.doi.org/10.1016/S0163-6383\(99\)80011-3](http://dx.doi.org/10.1016/S0163-6383(99)80011-3)
- Ekman, P., Friesen, W. V., & Hager, J. C. (2002) *Facial Action Coding System (FACS)*. Palo Alto, CA: Consulting Psychologists Press.
- Fernández-Abascal, E. G., Martínez-Sánchez, F., & Chóliz, M. (2009). *Guía de la expresión del bebé* [Guide of the Expression of Babies]. Madrid, Spain: Roche.
- Fox, N., & Davidson, R. J. (1988). Patterns of brain electrical activity during facial signs of emotion in 10 month old infants. *Developmental Psychology*, *24*, 230-236. <http://dx.doi.org/10.1037//0012-1649.24.2.230>
- Galati, D., & Lavelli, M. (1997). Neonate and infant emotion expression perceived by adults. *Journal of Nonverbal Behavior*, *21*, 57-83. <http://dx.doi.org/10.1023/A:1024999818682>
- Goberman, A., & Robb, M. (1999). Acoustic examination of pre-term and full-term infant cries: The long-time average spectrum. *Journal of Speech, Language, and Hearing Research*, *42*, 850-861.
- Green, J. A., Gustafson, G. E., & McGuie, A. C. (1998). Changes in infants' cries as a function of time in a cry bout. *Child Development*, *69*, 271-279. <http://dx.doi.org/10.1111/j.1467-8624.1998.tb06187.x>
- Green, J. A., Jones, L. E., & Gustafson, G. E. (1987). Perception of cries by parents and nonparents: Relation to cry acoustics. *Developmental Psychology*, *23*, 370-382. <http://dx.doi.org/10.1037/0012-1649.23.3.370>
- Greenwald, M. K., Cook, E. W., & Lang, P. J. (1989). Affective judgment and psychophysiological response: Dimensional covariation in the evaluation of pictorial stimuli. *Journal of Psychophysiology*, *3*, 51-64.
- Irwin, J. R. (2003). Parent and nonparent perception of the multimodal infant cry. *Infancy*, *4*, 503-516. http://dx.doi.org/10.1207/S15327078IN0404_06
- Lang, P. J. (1980). Behavioral treatment and bio-behavioral assessment: Computer applications. In J. B. Sidowski, J. H. Johnson, & T. A. Williams (Eds.), *Technology in mental health care delivery systems* (pp. 119-137). Norwood, NJ: Ablex.
- Leeds, L., & Thompson, J. (2005). Tears as tools: How to learn from crying. *Early Years: Journal of the Texas Association for the Education of Young Children*, *27*, 5-6.
- Long, T., & Johnson, M. (2001). Living and coping with excessive infantile crying. *Journal of Advanced Nursing*, *34*, 155-162. <http://dx.doi.org/10.1046/j.1365-2648.2001.01740.x>
- Lummaa, V., Vuorisalo, T., Bard, R. G., & Lehtonen, L. (1998). Why cry?: Adaptive significance of intensive crying in human infants. *Evolution and Human Behavior*, *19*, 193-202. [http://dx.doi.org/10.1016/S1090-5138\(98\)00014-2](http://dx.doi.org/10.1016/S1090-5138(98)00014-2)
- McLaughlin, C. R., Hull, J. G., Edwards, W. H., Cramer, C. P., & Dewey, W. L. (1993). Neonatal pain: A comprehensive survey of practices. *Journal of Pain and Symptom Management*, *8*, 7-16. [http://dx.doi.org/10.1016/0885-3924\(93\)90114-B](http://dx.doi.org/10.1016/0885-3924(93)90114-B)
- McNeil, D. W., & Brunetti, D. G. (1992). Pain and fear: A bioinformational perspective on responsivity to imagery. *Behavior Research Therapy*, *30*, 513-520. [http://dx.doi.org/10.1016/0005-7967\(92\)90035-F](http://dx.doi.org/10.1016/0005-7967(92)90035-F)
- Messinger, D. S. (2002). Positive and negative: Infant facial expressions and emotions. *Current Directions in Psychological Science*, *11*, 1-6. <http://dx.doi.org/10.1111/1467-8721.00156>
- Miller, G. A., Levin, D. N., Kozak, M. J., Cook, E. W. III, McLean, A., & Lang, P. J. (1987). Individual differences in imagery and the psychophysiology of emotion. *Cognition and Emotion*, *1*, 367-390. <http://dx.doi.org/10.1080/02699938708408058>
- Newman, J. D. (2007). Neural circuits underlying crying and cry responding in mammals. *Behavioural Brain Research*, *182*, 155-165. <http://dx.doi.org/10.1016/j.bbr.2007.02.011>
- Oster, H., Hegley, D., & Nagel, L. (1992). Adult judgments and fine-grained analysis of infant facial expressions: Testing the validity of a priori coding formulas. *Developmental Psychology*, *28*, 1115-1131. <http://dx.doi.org/10.1037/0012-1649.28.6.1115>
- Prkachin, K. M. (1992). The consistency of facial expressions of pain: A comparison across modalities. *Pain*, *51*, 297-306. [http://dx.doi.org/10.1016/0304-3959\(92\)90213-U](http://dx.doi.org/10.1016/0304-3959(92)90213-U)
- Protopapas, A., & Lieberman, P. (1997). Fundamental frequency of phonation and perceived emotional stress. *Journal of the Acoustical Society of America*, *101*, 2267-2277. <http://dx.doi.org/10.1121/1.418247>
- Rautava, L., Lempinen, A., Ojala, S., Parkkola, R., Rikalainen, H., Lapinleimu, H., ... Lehtonen, L. (2007). Acoustic quality of cry in very-low-birth-weight infants at the age of 1 1/2 years. *Early Human Development*, *83*, 5-12. <http://dx.doi.org/10.1016/j.earlhumdev.2006.03.004>
- Robb, M. P., Crowell, D. H., Dunn-Rankin, P., & Tinsley, C. (2007). Cry features in siblings of SIDS. *Acta Paediatrica*, *96*, 1404-1408. <http://dx.doi.org/10.1111/j.1651-2227.2007.00486.x>
- Runefors, P., & Arnbjörnsson, E. (2005). A sound spectrogram analysis of children's crying after painful stimuli during the first year of life. *Pholia Phoniatica et Logopaedica*, *57*, 90-95. <http://dx.doi.org/10.1159/000083570>
- Soltis J. (2004). The developmental mechanisms and the signal functions of early infant crying. *Behavioral and Brain Sciences*, *27*, 443-458. <http://dx.doi.org/10.1017/S0140525X0400010X>
- Williams, A. C. (2002). Facial expression of pain: An evolutionary account. *Behavioral and Brain Sciences*, *25*, 439-455. <http://dx.doi.org/10.1017/S0140525X02000080>
- Wolff, P. H. (1969). The natural history of crying and other vocalizations in early infancy. In B. Foss (Ed.), *Determinants of infant behavior* (pp. 81-109). London, England: Methuen.

- Zeifman, D. M. (2001). An ethological analysis of human infant crying: Answering Tinbergen's four questions. *Developmental Psychobiology*, *39*, 265–285. <http://dx.doi.org/10.1002/dev.1005>
- Zeifman, D. M. (2003). Predicting adult responses to infant Distress: Adult characteristics associated with perceptions, emotional reactions, and timing of intervention. *Infant Mental Health Journal*, *24*, 597–612. <http://dx.doi.org/10.1002/imhj.10077>
- Zeskind, P. S., Marshall, T. R., & Goff, D. M. (1996). Cry threshold predicts regulatory disorder in newborn infants. *Pediatric Psychology*, *21*, 803–819. <http://dx.doi.org/10.1093/jpepsy/21.6.803>

Received November 21, 2010

Revision received November 3, 2011

Accepted December 28, 2011