

CONNECTEDNESS IN STRUCTURES ON THE REAL NUMBERS: O-MINIMALITY AND UNDECIDABILITY

ALFRED DOLICH, CHRIS MILLER, ALEX SAVATOVSKY, AND
ATHIPAT THAMRONGTHANYALAK

Abstract. We initiate an investigation of structures on the set of real numbers having the property that path components of definable sets are definable. All o-minimal structures on $(\mathbb{R}, <)$ have the property, as do all expansions of $(\mathbb{R}, +, \cdot, \mathbb{N})$. Our main analytic-geometric result is that any such expansion of $(\mathbb{R}, <, +)$ by Boolean combinations of open sets (of any arities) either is o-minimal or defines an isomorph of $(\mathbb{N}, +, \cdot)$. We also show that any given expansion of $(\mathbb{R}, <, +, \mathbb{N})$ by subsets of \mathbb{N}^n (n allowed to vary) has the property if and only if it defines all arithmetic sets. Variations arise by considering connected components or quasicomponents instead of path components.

§1. Introduction. We are interested in structures on the set of real numbers, especially expansions of the real field $(\mathbb{R}, +, \cdot)$ by locally path connected sets, having the property that each path component of each definable set (allowing parameters, and of any arity) is definable. Variations on the theme arise by considering connected components and quasicomponents. Our original motivation lies in real-analytic geometry, but we have come to believe that a more foundational investigation is in order. Thus, in this paper, we provide some fundamental logical results and some examples.

Some global conventions. The reader is assumed to be familiar with basic topology (e.g., [18]) and mathematical logic (especially o-minimality, e.g., [5]). Our default is that definability (in any given structure) allows parameters (from the underlying set of the structure) and we identify interdefinable structures. Whenever syntactic dependence on the language is relevant, we shall make it clear. We always regard each \mathbb{R}^n as equipped with its usual topology, and subsets of \mathbb{R}^n with the induced topology. We abbreviate “connected component” by “component.” The set of all nonnegative integers is denoted by \mathbb{N} .

Proofs of results stated in this introduction are postponed to later in the paper.

DEFINITIONS. A structure with underlying set \mathbb{R} is:

- (1) *path-component closed*, or *PCC* for short, if for every definable set E , each path component of E is definable;

Received July 13, 2020.

2020 *Mathematics Subject Classification.* 03C64, 03D35, 54D99.

Key words and phrases. o-minimal, locally o-minimal, path component, quasicomponent, undecidable.

- (2) *component closed*, or *CC* for short, if (1) holds with “component” in place of “path component”;
- (3) *quasicomponent closed*, or *QCC* for short, if (1) holds with “quasicomponent” in place of “path component.”

Note that every structure on \mathbb{R} satisfying any of these conditions defines the usual order $<$ on \mathbb{R} . (Consider $\{(x, y) \in \mathbb{R}^2 : x \neq y\}$.) Thus, the definitions are really about expansions of $(\mathbb{R}, <)$.

We suspect that, in this generality, none of these conditions imply any of the others, but our candidates for counterexamples are ad hoc and unverified as yet. Currently we are most interested in PCC structures, but simultaneous consideration of the other two conditions is natural.

Trivially, the expansion of \mathbb{R} by each subset of \mathbb{R}^n as n ranges over the positive integers is PCC, CC and QCC. Thus, abstractly, every structure on \mathbb{R} has a least expansion that is PCC, CC and QCC; of course, this holds also for each of the conditions individually and pairwise. Relative to known results, it is easy to see that there exist two concrete classes of nontrivial examples.

PROPOSITION 1.1. *Every o-minimal expansion of $(\mathbb{R}, <)$ is PCC, CC and QCC. Every expansion of $(\mathbb{R}, +, \cdot, \mathbb{N})$ is PCC, CC and QCC.*

O-minimal expansions of $(\mathbb{R}, <)$ have been studied extensively. Expansions of $(\mathbb{R}, +, \cdot, \mathbb{N})$ are too complicated for us to study as definability theory (every real projective set is definable). The main underlying reason for starting this investigation was to see if certain properties of o-minimal expansions of $(\mathbb{R}, +, \cdot)$ extend to some other settings. Thus, we are interested in PCC structures on the real field that are generated by locally path connected sets, but neither are o-minimal nor define \mathbb{N} . Recent work of the third author [21] provides some examples, but by construction, they are easily seen to interpret $(\mathbb{N}, +, \cdot)$ (and thus to have undecidable theories). We show here that the interpretability of $(\mathbb{N}, +, \cdot)$ is unavoidable, even in much leaner structures.

Notation. Throughout, $|$ indicates the usual divisibility relation on \mathbb{N} , regarded as the set $\{(n, dn) : n, d \in \mathbb{N}\}$.

By Robinson [20], $(\mathbb{N}, <, |)$ is interdefinable with $(\mathbb{N}, +, \cdot)$, hence also with the expansion of \mathbb{N} by all arithmetic sets (of any arity); we tend to use this fact without further mention.

THEOREM 1.2. *If \mathfrak{R} is an expansion of $(\mathbb{R}, <, +)$ by Boolean combinations of open subsets of various \mathbb{R}^n , and is PCC, CC or QCC, then exactly one of the following holds.*

- (1) \mathfrak{R} is o-minimal.
- (2) There is a strictly increasing $\sigma : \mathbb{N} \rightarrow \mathbb{R}$ such that $\{(\sigma(m), \sigma(n)) : m | n\}$ is definable.

As we shall see later, every expansion of $(\mathbb{R}, <, +, |)$ by subsets of various \mathbb{N}^n is PCC, CC and QCC. Trivially, there are plenty of examples of expansions of $(\mathbb{R}, +, \cdot)$ for which it is known that condition (2) holds without the assumption of PCC, CC or QCC, but there are also such examples for which every definable set is a finite union of locally path connected definable sets: see [8, 9, 13, 17, 23].

COROLLARY 1.3. *If \mathfrak{A} is a PCC expansion of $(\mathbb{R}, <, +)$ generated by topological submanifolds, and \mathfrak{A} is not o-minimal, then no expansion of \mathfrak{A} has a decidable theory.*

This is perhaps not so surprising, but also not as discouraging as it might seem. Definability is generally more important than abstract interpretability in the analytic geometry of expansions of $(\mathbb{R}, <)$.

Theorem 1.2 relies on the following technical result.

PROPOSITION 1.4. *If $\emptyset \neq A \subseteq \mathbb{R}$ has empty interior and $f : A \rightarrow A$ is strictly increasing and strictly dominates the identity, then there is a strictly increasing $\sigma : \mathbb{N} \rightarrow \mathbb{R}$ such that every expansion of $(\mathbb{R}, <, f)$ that is PCC, CC or QCC defines $\{(\sigma(m), \sigma(n)) : m \mid n\}$.*

(By “strictly dominates the identity” we mean that $x < f(x)$ for all x in the domain of f . For logicians: The function f is regarded as a subset of \mathbb{R}^2 , not the interpretation of a unary function symbol.) A key step in the proof is the special case that $A = \mathbb{N}$ and f is the usual successor function on \mathbb{N} .

PROPOSITION 1.5. *Every expansion of $(\mathbb{R}, <, \mathbb{N})$ that is PCC, CC or QCC defines \mid .*

Via quantifier elimination in an appropriate language, it is easy to see that $(\mathbb{R}, <, \mathbb{N})$ does not define $\{2n : n \in \mathbb{N}\}$; then it does not define \mid , and so is neither PCC, CC nor QCC.

It appears to us at this time that dealing with arbitrary expansions of $(\mathbb{R}, <, +)$ is daunting, especially those that define a bijection between a bounded interval and an unbounded interval. Thus, we first attempt to understand some less complicated structures.

From now on: \mathfrak{A} denotes a fixed, but arbitrary, expansion of $(\mathbb{R}, <)$.

We say that \mathfrak{A} is *locally o-minimal* if for each definable $E \subseteq \mathbb{R}$ and $x \in \mathbb{R}$ there is an open interval U containing x such that $E \cap U$ is a finite union of points and open intervals. (One might find different definitions in the literature, but as far as we know, all are equivalent over $(\mathbb{R}, <)$.) Evidently, every o-minimal expansion of $(\mathbb{R}, <)$ is locally o-minimal, but there are locally o-minimal expansions of $(\mathbb{R}, <)$ that are not o-minimal. Of particular importance in this paper is that the expansion of $(\mathbb{R}, <, +)$ by all subsets of each \mathbb{N}^n (as n ranges over positive integers), is locally o-minimal (see, e.g., [8]), and so the same is true of all of its reducts. Thus, $(\mathbb{R}, <, \mathbb{N})$ is locally o-minimal, but neither PCC, CC nor QCC.

PROPOSITION 1.6. *The following are equivalent:*

- (1) \mathfrak{A} is locally o-minimal.
- (2) If $E \subseteq \mathbb{R}^n$ is bounded and definable, then the expansion of $(\mathbb{R}, <)$ by all definable subsets of E is o-minimal.
- (3) Every definable set is locally path connected.
- (4) For every definable set, its components are the same as its path components and its quasicomponents.
- (5) Components of bounded definable subsets of \mathbb{R}^2 are path connected.
- (6) Quasicomponents of bounded definable subsets of \mathbb{R}^2 are connected.
- (7) If $A \subseteq \mathbb{R}$ is definable and has empty interior, then A is closed and discrete.

(Most of the implications are either trivial or easy exercises in topology that can be done on their own, but (2) \Rightarrow (3) will require some explanation.)

COROLLARY 1.7. *If \mathfrak{R} is locally o-minimal, then it is PCC if and only if it is CC, if and only if it is QCC.*

Thus, when dealing with locally o-minimal expansions of $(\mathbb{R}, <)$, we may work with any of the conditions (PCC, CC or QCC) as convenient. We present a class of examples.

PROPOSITION 1.8. *Let \mathfrak{R} be an expansion of $(\mathbb{R}, <, +, |)$ by subsets of various \mathbb{N}^n .*

- (1) *Every bounded definable set is definable in $(\mathbb{R}, <, +)$.*
- (2) *If E is definable and connected, then for all $x, y \in E$ there is a path in E definable in $(\mathbb{R}, <, +)$ joining x to y .*
- (3) *\mathfrak{R} is PCC.*

REMARKS. (a) Thus, \mathfrak{R} is not just locally o-minimal, but “locally o-minimal with respect to $(\mathbb{R}, <, +)$.” This is neither surprising nor necessarily original, nor is it difficult to then derive (2). The point is that \mathfrak{R} is PCC; our proof of this requires (2) and our proof of (1). (b) Trivially, the theory of the expansion of \mathbb{R} by all subsets of each \mathbb{N}^n interprets every countable theory. Thus, in contrast to its local geometry, the model theory of \mathfrak{R} can be quite wild. (c) The group structure is not necessary for either (1) or (3) to hold, but (2) can fail. To illustrate, it is not hard to check (or see [15]) that the expansion of $(\mathbb{R}, <)$ by all subsets of each \mathbb{N}^n is PCC, and every definable subset of any $(-\infty, b)^n$ with $b \in \mathbb{R}$ is definable in $(\mathbb{R}, <)$. But there is no definable path joining any point in the definable set $(-\infty, 1) \times (-\infty, 2)$ to the point $(1, 2)$.

Observe that \mathbb{N} is \emptyset -interdefinable with \mathbb{Z} over $(\mathbb{R}, <, +)$. By combining results 1.5, 1.7 and 1.8, we obtain the following characterization.

THEOREM 1.9. *If \mathfrak{R} is an expansion of $(\mathbb{R}, <, +, \mathbb{Z})$ by subsets of various \mathbb{Z}^n , then \mathfrak{R} is PCC, CC or QCC if and only if it defines all arithmetic sets.*

We now say more about the original motivation for this work. One might be interested in understanding “reachability” properties of given $E \subseteq \mathbb{R}^n$. This can be made more precise by considering what is known if $(\mathbb{R}, +, \cdot, E)$ is o-minimal. Since path components of E are definable, it suffices to consider the case that E is path connected; then it is path connected in a strong sense: (a) there is a definable map $\gamma: E^2 \times [0, 1] \rightarrow E$ such that, for all $x, y \in E$, the path $t \mapsto \gamma(x, y, t): [0, 1] \rightarrow E$ is rectifiable and joins x to y ; (b) if moreover E is compact, then there is a definable function $f: [0, \infty) \rightarrow [0, \infty)$ such that, for all $x, y \in E$, the length of $t \mapsto \gamma(x, y, t)$ is bounded by $f(\|x - y\|)$. (See [6, 4.21] for details.) These are desirable properties in real-analytic geometry and control theory, and we hope that at least something similar will hold for certain cases that $(\mathbb{R}, +, \cdot, E)$ is not o-minimal. Here is a case of particular interest. Let ω be a nonzero real number, S be the logarithmic spiral $\{e^t \cos(\omega t), e^t \sin(\omega t) : t \in \mathbb{R}\}$, and E be definable in $(\mathbb{R}, +, \cdot, S)$. Evidently, $(\mathbb{R}, +, \cdot, S)$ is not locally o-minimal, but it is known to have a number of desirable analytic-geometric properties; see, e.g., [14, 4.4], [16], and [25, Theorem 4.1.1]. Some of these properties, in combination with Theorem 1.2, reveal that $(\mathbb{R}, +, \cdot, S)$ is not PCC, but perhaps there might be PCC expansions of $(\mathbb{R}, +, \cdot, S)$ in which most of these good properties, or variants thereof, are preserved. At present, all we know is that there exist PCC expansions $(\mathbb{R}, +, \cdot, S)$ that preserve some of its good properties

but fail to preserve some others. It remains to be seen if enough of the properties useful for reachability analysis can be preserved in a PCC expansion of $(\mathbb{R}, +, \cdot, S)$. See also [1, 11, 22, 24] for some related material on reachability properties of sets definable in certain expansions of $(\mathbb{R}, <)$.

The previous paragraph explains somewhat why we have so far mentioned only working over the real line. But the question does arise: What about expansions of other dense linear orders, or even more generally, first-order topological structures as defined in [19]? We defer discussion of these more general settings to the end of the paper.

Some history and attributions. The original questions underlying this research were raised by Thamrongthanyalak in conversations with Miller. Some early results, including some first steps toward Theorem 1.9, were documented in [15]. (See also [7].) Savatovsky became interested in the project after attending a presentation by Miller at Universität Konstanz in May 2017, subsequently leading to the establishment of Proposition 1.5 and the motivating case (namely, $\mathfrak{R} = (\mathbb{R}, <, +, \cdot)$) for Proposition 1.8. The proof of Proposition 1.8.3 presented here is due essentially to Dolich. Some earlier work of Kawakami et al. [10, Section 4] is related to Proposition 1.8.1, but the different setting makes comparisons cumbersome.

§2. Proofs. We now provide proofs of the results stated in the introduction (but not in the same order as they were stated). As before, \mathfrak{R} denotes an arbitrary expansion of $(\mathbb{R}, <)$.

We begin with some conventions and routine facts from topology. Let Y be a topological space and $X \subseteq Y$. The closure of X is denoted by \overline{X} . We say that X is locally connected if, in the subspace topology, X has a basis consisting of connected sets. If $u, v \in X$, then a path in X from u to v is a continuous map γ from a nonempty compact interval $[a, b] \subseteq \mathbb{R}$ into Y such that $\gamma(a) = u$, $\gamma(b) = v$, and $\gamma([a, b]) \subseteq X$. The set X is path connected if for every $u, v \in X$ there is a path in X from u to v , and is locally path connected if, in the subspace topology, X has a basis consisting of path-connected sets.

2.1. Here are some facts to keep in mind.

- The component of $y \in Y$ is the union of all connected sets containing y (and similarly for path components).
- The quasicomponent of $y \in Y$ is the intersection of all clopen sets containing y .
- If X is a component or a quasicomponent of Y , then X is closed.
- If Y is locally connected, then its quasicomponents and its components are the same.
- If Y is locally path connected, then its path components and its components are the same (which in turn are the same as its quasicomponents).
- If Y has a countable basis at $y \in Y$ consisting of connected sets and $Y \setminus \{y\}$ is locally path connected, then Y is locally path connected.

REMARK. There are closed subsets of \mathbb{R}^2 having quasicomponents that are not components, e.g., $\{-1, 1\} \times \mathbb{R}$ is a quasicomponent of the closure of the union of the boundaries of the boxes $(-1 + 2^{-n}, 1 - 2^{-n}) \times (-2^n, 2^n)$, $n \in \mathbb{N}$.

PROOF OF PROPOSITION 1.1. Suppose that \mathfrak{R} expands $(\mathbb{R}, +, \cdot, \mathbb{N})$. We show that \mathfrak{R} is PCC, CC and QCC. Let $n \in \mathbb{N}$. Recall (see, e.g., [5, p. 16]) that there exist $m \in \mathbb{N}$ and $Z \subseteq \mathbb{R}^m \times \mathbb{R}^n$ such that Z is \emptyset -definable in $(\mathbb{R}, +, \cdot, \mathbb{N})$ and $\{ \{ y \in \mathbb{R}^n : (a, y) \in Z \} : a \in \mathbb{R}^m \}$ is exactly the collection of the closed subsets of \mathbb{R}^n . Let $E \subseteq \mathbb{R}^n$. If X is either a component or a quasicomponent of E , then X is closed in E , and so $(\mathbb{R}, +, \cdot, \mathbb{N}, E)$ defines X . Let X be a path component of E ; we show that $(\mathbb{R}, +, \cdot, \mathbb{N}, E)$ defines X . It suffices to fix $x \in X$ and show that the set of all $v \in \mathbb{R}^n$ for which there is a path in E from x to v is definable in (\mathbb{R}, Z, E) . Now, $v \in X$ if and only if there is a continuous $\gamma : [0, 1] \rightarrow \mathbb{R}^n$ such that $\gamma(0) = x$, $\gamma(1) = v$, and the image of $[0, 1]$ under γ is contained in E . To put this another way, $v \in X$ if and only if there exists $a \in \mathbb{R}^m$ such that: the fiber $Z_a := \{ y \in \mathbb{R}^n : (a, y) \in Z \}$ is a bounded subset of E ; for all $t \in [0, 1]$ there exists a unique $y \in \mathbb{R}^n$ such that $(t, y) \in [0, 1] \times Z_a$; and, the points $(0, x)$ and $(1, v)$ belong to $[0, 1] \times Z_a$. (The resulting function is continuous because its graph is closed.) As the set of all such v is definable in $(\mathbb{R}, +, \cdot, \mathbb{N}, E)$, so is X .

Suppose that \mathfrak{R} is o-minimal. We show that \mathfrak{R} is PCC, CC and QCC. Each definable set has only finitely many components, each of which is definable [5, Chapter 3, (2.18) and (2.19).7]. Hence, \mathfrak{R} is CC. For PCC and QCC, it suffices by the basic topological facts to show that every definable set is locally path connected. By cell decomposition and a routine induction on dimension, it suffices to let $C \subseteq \mathbb{R}^n$ be a cell of \mathfrak{R} and $y \in \overline{C} \setminus C$, and show that $\{y\} \cup C$ is locally path connected. It is an exercise to see that $\{y\} \cup C$ is locally connected at y (indeed, see [5, Chapter 3, (2.19).8]), that is, in the subspace topology, $\{y\} \cup C$ has a basis at y consisting of connected sets; as we are working over \mathbb{R} , we may take this basis to be countable. Now, $(\{y\} \cup C) \setminus \{y\} = C$, and cells are locally path connected. By the last item of 2.1, $\{y\} \cup C$ is locally path connected at y (as was to be shown). ⊣

PROOF OF PROPOSITION 1.6. This is mostly just an exercise, so we give only an outline.

(1)⇒(2). Let \mathfrak{R} be locally o-minimal. Let $E \subseteq \mathbb{R}^n$ be bounded and definable. We contend that the expansion of $(\mathbb{R}, <)$ by all definable subsets of E is o-minimal. By the Bolzano–Weierstrass Theorem, every bounded subset of \mathbb{R} definable in \mathfrak{R} is a finite union of points and open intervals. Thus, there is an open interval $I \subseteq \mathbb{R}$ such that the expansion of $(I, <)$ by all subsets of E definable in \mathfrak{R} is o-minimal. It is now routine to see that the expansion of $(\mathbb{R}, <)$ by all definable subsets of E is also o-minimal.

(2)⇒(3). Recall the proof of Proposition 1.1.

(3)⇒(4) is just topology, and (4)⇒((5) & (6)) is trivial.

(5)⇒(7). If $E \subseteq \mathbb{R}$ has empty interior and a limit point c , then

$$(E \setminus \{c\} \times [0, 1]) \cup \{(c, 1)\} \cup (\mathbb{R} \times \{0\})$$

is connected, but not path connected.

(6)⇒(7). If $E \subseteq \mathbb{R}$ has empty interior and a limit point c , then $\{(c, 0), (c, 1)\}$ is a quasicomponent of its union with $(E \setminus \{c\}) \times [0, 1]$.

(7)⇒(1). The boundary of every definable subset of \mathbb{R} is closed and discrete. ⊣

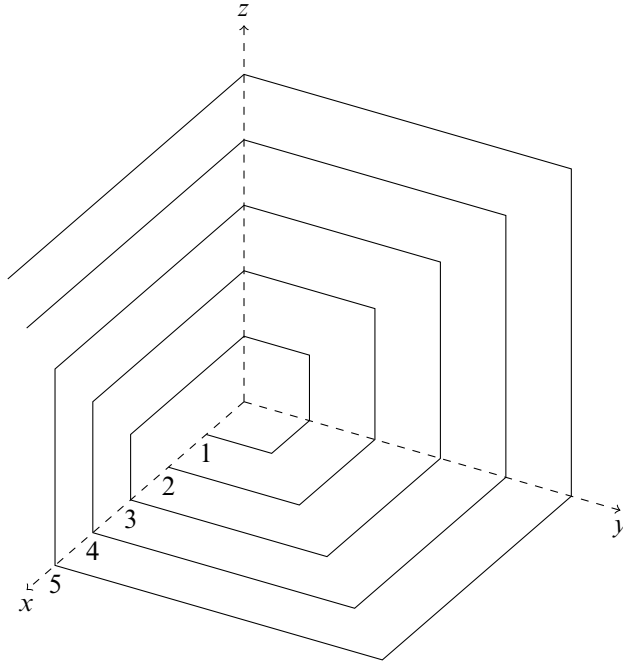

FIGURE 1. \mathbb{S}_2 near the origin.

PROOF OF PROPOSITION 1.5. Suppose that \mathfrak{R} defines \mathbb{N} and is PCC, CC or QCC. We show that \mathfrak{R} defines $|$. For $d \in \mathbb{N}$, put $d\mathbb{N} := \{dn : n \in \mathbb{N}\}$. As $a \mid b$ if and only if $b\mathbb{N} \subseteq a\mathbb{N}$, it suffices to show that $\bigcup_{d \in \mathbb{N}} (\{d\} \times d\mathbb{N})$ is definable.

First we show that each $d\mathbb{N}$ is definable. Let \mathbb{S}_0 be the intersection of the boundary of $(0, \infty)^3$ with the union of the boundaries of the boxes $(-n, n)^3$, $0 < n \in \mathbb{N}$. Put $P = \{(x, 0, z) \in \mathbb{R}^3 : x, z > 0\}$. For $d \in \mathbb{N}$, put

$$\mathbb{S}_d = (\mathbb{S}_0 \setminus P) \cup ((\mathbb{S}_0 \cap P) + (d, 0, 0)) \cup ([0, d] \times \{0\} \times \mathbb{N}^{>0}).$$

In words, \mathbb{S}_d is the result of replacing $\mathbb{S}_0 \cap P$ by shifting it d units in the positive x direction and then filling in the resulting gaps with the line segments $[0, d] \times \{0\} \times \{n\}$, $n > 0$. (See Figure 1 for $d = 2$.) Observe that \mathbb{S}_d is locally path connected, definable in $(\mathbb{R}, <, \mathbb{N})$ and $(d, 0, 0) \in \mathbb{S}_d$. Let C_d be the component of \mathbb{S}_d that contains $(d, 0, 0)$; then C_d is also the path component and the quasicomponent that contains $(d, 0, 0)$, and thus is definable. The intersection of C_d with the positive x -axis is the set $\{(d(n + 1), 0, 0) : n \in \mathbb{N}\}$. (See Figure 2 for $d = 2$.) As C_d is definable, so is $d\mathbb{N}$. Note that we could have obtained $d\mathbb{N}$ instead by first obtaining the set $\{dn + 1 : n \in \mathbb{N}\}$, which is the intersection of the positive x -axis with the component of \mathbb{S}_d that contains $(1, 0, 0)$.

Let $+\uparrow\mathbb{N}^2$ denote addition on \mathbb{N} , regarded as a subset of \mathbb{R}^3 . Examination of the construction of the sets \mathbb{S}_d yields that $\bigcup_{d \in \mathbb{N}} (\{d\} \times \mathbb{S}_d)$ is locally path connected and definable in $(\mathbb{R}, <, +\uparrow\mathbb{N}^2)$ (because shifting by d units along the

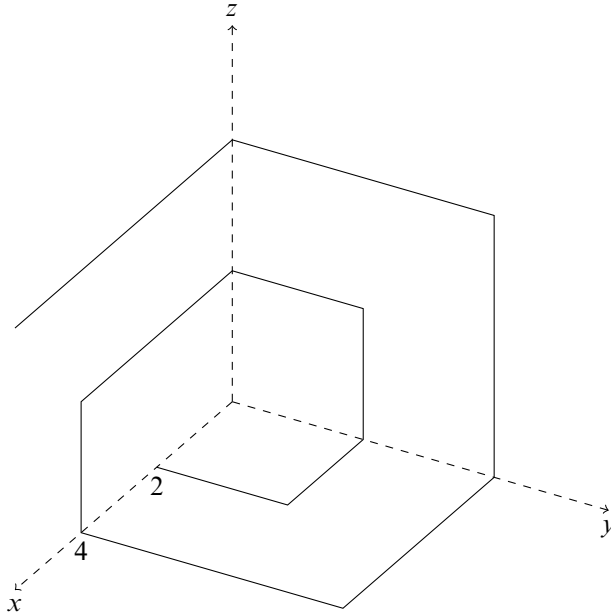

FIGURE 2. C_2 near the origin.

positive x -axis is uniformly definable). Let C be the component of $\{(t, 1, 0, 0) : t \in \mathbb{R}\} \cup \bigcup_{d \in \mathbb{N}} (\{d\} \times \mathbb{S}_d)$ that contains $(1, 1, 0, 0)$. Again, C is also the path component and the quasicomponent that contains $(1, 1, 0, 0)$, and thus is definable. Observe that $C \cap \{(j, k, 0, 0) : j, k \in \mathbb{N}\} = \bigcup_{d \in \mathbb{N}} \{(d, dn + 1, 0, 0) : n \in \mathbb{N}\}$. Thus, $\bigcup_{d \in \mathbb{N}} (\{d\} \times \{dn + 1 : n \in \mathbb{N}\})$ is definable, yielding that $\bigcup_{d \in \mathbb{N}} (\{d\} \times d\mathbb{N})$ is definable (as was to be shown). Hence, in order to finish the proof, it suffices to show that $\{(a, b, c) \in \mathbb{N}^3 : a \leq b \ \& \ a + b = c\}$ is definable (as then $+\lceil \mathbb{N}^2$ is also definable).

Let χ denote the characteristic function of the set of odd natural numbers as a subset of \mathbb{R} . For each $m, n \in \mathbb{N}$ with $m \leq n$, let $\Gamma_{m,n}$ be the union of the images of the paths

$$\begin{aligned} t &\mapsto (m, n, t, \chi(m)t, \chi(n)t) : [0, 1] \rightarrow \mathbb{R}^5, \\ t &\mapsto (t, n, 1, \chi(m), \chi(n)) : [m, m + 1] \rightarrow \mathbb{R}^5, \\ t &\mapsto (m + 1, t, 1, \chi(m), \chi(n)) : [n, n + 1] \rightarrow \mathbb{R}^5, \\ t &\mapsto (m + 1, n + 1, t, \chi(m)t, \chi(n)t) : [0, 1] \rightarrow \mathbb{R}^5. \end{aligned}$$

Each path is definable in $(\mathbb{R}, <)$, and $\Gamma_{m,n}$ is definable in $(\mathbb{R}, <)$, connected and compact. If $j, k \in \mathbb{N}$ and $j \leq k$, then $\Gamma_{j,k} \cap \Gamma_{m,n}$ is equal to one of the following:

$$\emptyset, \Gamma_{m,n}, \{(m, n, 0, 0, 0, 0)\}, \{(m + 1, n + 1, 0, 0, 0, 0)\}.$$

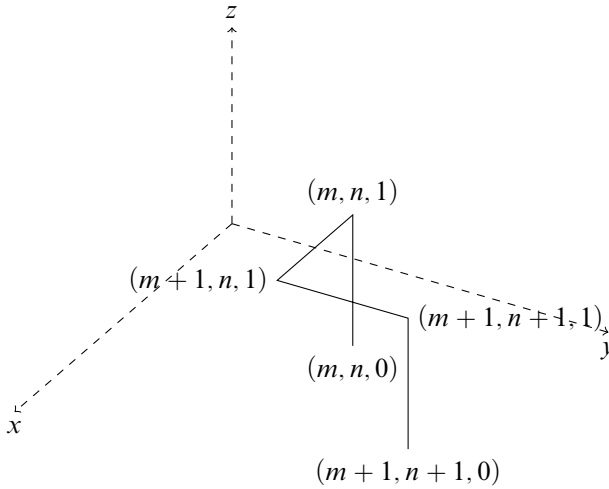

FIGURE 3. The projection of $\Gamma_{m,n}$ on the first three coordinates.

It is perhaps helpful to regard the pair $(\chi(m), \chi(n)) \in \{0, 1\}^2$ as a color assigned to the projection of $\Gamma_{m,n}$ on the first three coordinates, and then to regard projections having different colors as being disjoint except possibly at the endpoints in the xy -plane (see Figure 3). Hence, for each $d \in \mathbb{N}$, $\{d\} \times \bigcup_{k \in \mathbb{N}} \Gamma_{k,d+k}$ is the component of $\{d\} \times \bigcup_{m,n \in \mathbb{N}} \Gamma_{m,n}$ that contains $(d, 0, d, 0, 0, 0)$. Let L be the line in \mathbb{R}^6 containing both the origin and $(1, 0, 1, 0, 0, 0)$. Put $E = L \cup (\mathbb{N} \times \bigcup_{m \leq n \in \mathbb{N}} \Gamma_{m,n})$ and note that E is definable in $(\mathbb{R}, <, \mathbb{N}, 2\mathbb{N})$. Let D be the component of E that contains the origin. As before, D is definable. It is routine to see that $L \cup \bigcup_{d,k \in \mathbb{N}} (\{d\} \times \Gamma_{k,d+k})$ is closed, contained in D , and open in D ; thus, $D = L \cup \bigcup_{d,k \in \mathbb{N}} (\{d\} \times \Gamma_{k,d+k})$. If $(a, b, c) \in \mathbb{N}^3$, then $(a, b, c, 0, 0, 0) \in D$ if and only if $a \leq b$ and $c = a + b$. Hence, $\{(a, b, c) \in \mathbb{N}^3 : a \leq b \ \& \ a + b = c\}$ is definable, as was to be shown. \dashv

Note. We did not need PCC, CC or QCC per se, only that certain rather special kinds of path-connected subsets of certain rather special definable sets are definable. We discuss this further at the end of the paper.

PROOF OF THEOREM 1.4. Let $\emptyset \neq A \subseteq \mathbb{R}$ have empty interior and $f : A \rightarrow A$ be strictly increasing and strictly dominating the identity. We find a strictly increasing $\sigma : \mathbb{N} \rightarrow \mathbb{R}$ such that every expansion of $(\mathbb{R}, <, f)$ that is PCC, CC or QCC also defines $\{(\sigma(m), \sigma(n)) : m \mid n\}$. Note that A cannot have a maximal element and there exists $a_0 \in A$ such that $A \cap [a_0, \infty)$ is infinite. By replacing A with $A \cap [a_0, \infty)$ and f with its restriction to $A \cap [a_0, \infty)$ we reduce to the case that $\min A$ exists; for ease of notation, say $\min A = 0$. We obtain a subset S of \mathbb{R}^3 by repeating the construction of \mathbb{S}_1 (as in the proof of 1.5), but with A instead of \mathbb{N} , and f instead of the successor function on \mathbb{N} . Note that S is definable in $(\mathbb{R}, <, f)$. Let P be the path component of S that contains $f(0)$. Note that P is a component and a

quasicomponent of S , and the intersection of P with $[0, \infty) \times \{0\} \times \{0\}$ is the orbit of f on $f(0)$. Thus, it suffices to assume that A is the image of a strictly increasing function $\mathbb{N} \rightarrow \mathbb{R}$ and f is the successor function on A ; then $((-\infty, \sup A), <, A)$ is isomorphic to $(\mathbb{R}, <, \mathbb{N})$ and we apply Proposition 1.5 to finish. \dashv

PROOF OF THEOREM 1.2. Let \mathfrak{R} be an expansion of $(\mathbb{R}, <, +)$ by Boolean combinations of open sets. Suppose that \mathfrak{R} is PCC, CC or QCC, but is not o-minimal. We find a strictly increasing $\sigma : \mathbb{N} \rightarrow \mathbb{R}$ such that $\{(\sigma(m), \sigma(n)) : m \mid n\}$ is definable. It suffices by the proof of Theorem 1.4 to show that \mathfrak{R} defines the range of a strictly increasing sequence in \mathbb{R} . By Dougherty and Miller [4] and Dolich et al. [3], \mathfrak{R} defines an infinite discrete $A \subseteq \mathbb{R}$. If A is closed, then at least one of $A \cap [0, \infty)$ or $-A \cap [0, \infty)$ is the range of a strictly increasing sequence. Suppose now that A is not closed. Put $F = \overline{A} \setminus A$; then F is nonempty, has no interior, and is closed (because A is locally closed).

Suppose that F has no isolated points; then there exists $N \in \mathbb{N}$ such that $F \cap [-N, N]$ is a Cantor set. The set of negatives of lengths of the maximal open intervals of $[-N, N] \setminus F$ is definable and the range of a strictly increasing sequence of real numbers.

Suppose that F has an isolated point c . Let $x, y \in \mathbb{R}$ be such that $F \cap (x, y) = \{c\}$. As c is a limit point of A , at least one of $A \cap (x, c)$ or $A \cap (c, y)$ is infinite and discrete; assume the former (the latter is similar). By increasing x , we have that $A \cap (x, c)$ is the range of a strictly increasing sequence (because $A \cap (x, c)$ has no limit points in (x, c)). \dashv

REMARK. The last paragraph of the proof does not require the group structure.

We now begin to work toward the proof of Proposition 1.8.

2.2. Let \mathfrak{R}_0 be an o-minimal expansion of $(\mathbb{R}, <, +)$ such that every bounded set definable in \mathfrak{R} is definable in \mathfrak{R}_0 . Let $E \subseteq \mathbb{R}^n$ be connected and definable in \mathfrak{R} . Let $x, y \in E$. Then there is a path in E definable in \mathfrak{R}_0 joining x to y .

PROOF. As \mathfrak{R} is locally o-minimal, E is path connected. As images of paths are compact, there exist $N \in \mathbb{N}$ and a path in $E \cap [-N, N]^n$ joining x to y . By assumption, $E \cap [-N, N]^n$ is definable in \mathfrak{R}_0 . By o-minimality, the path components of $E \cap [-N, N]^n$ are definable in \mathfrak{R}_0 . Thus, we may reduce to the case that $E \cap [-N, N]^n$ is path connected. By Cell Decomposition and Curve Selection, there is a path in $E \cap [-N, N]^n$ joining x to y that is definable in \mathfrak{R}_0 . \dashv

For the remainder of this section, our approach will be more model theoretic than our earlier material. In particular, we use both “expansion” and “reduct” in the traditional first-order syntactic sense, “quantifier-free definable” means “defined by a quantifier-free formula of the language under consideration,” and “QE” abbreviates “quantifier elimination.”

Let $T_{\mathbb{Q}}$ be the theory of ordered \mathbb{Q} -vector spaces with a distinguished positive element, in the language $L_{\mathbb{Q}} := \{<, +, 0, 1\} \cup \{\lambda_q : q \in \mathbb{Q}\}$, where $0 < 1$ and λ_q is intended to indicate left scalar multiplication by q . Let $[\]$ be a new unary function symbol and put $L'_{\mathbb{Q}} = L_{\mathbb{Q}} \cup \{[\]\}$. Let $T'_{\mathbb{Q}}$ be the union of $T_{\mathbb{Q}}$ and the universal

closures of the following:

- $\lfloor [x] + y \rfloor = \lfloor x \rfloor + \lfloor y \rfloor$,
- $0 \leq x < 1 \rightarrow \lfloor x \rfloor = 0$,
- $\lfloor 1 \rfloor = 1$,
- $\lfloor x \rfloor \leq x < \lfloor x \rfloor + 1$.

Observe that as $T_{\mathbb{Q}}$ is universally axiomatizable, so is $T'_{\mathbb{Q}}$. By [12, Appendix], $T'_{\mathbb{Q}}$ has QE and is complete.¹ It is easy to see that $(\mathbb{R}, <, +, \mathbb{N})$ is \emptyset -interdefinable with $(\mathbb{R}, <, +, 0, 1, (q \cdot x)_{q \in \mathbb{Q}}, \lfloor \cdot \rfloor)$, where $\lfloor \cdot \rfloor$ denotes the usual “floor” function $t \mapsto \max(\mathbb{Z} \cap (-\infty, t])$ for $t \in \mathbb{R}$. Thus, $\text{Th}(\mathbb{R}, <, +, \mathbb{N})$ is bi-interpretable with $T'_{\mathbb{Q}}$. It is more convenient to prove Proposition 1.8 by working over $(\mathbb{R}, <, +, \mathbb{Z})$ instead of $(\mathbb{R}, <, +, \mathbb{N})$.

Let \mathfrak{Z} be a structure on \mathbb{Z} in a language $L_{\mathfrak{Z}}$ such that:

- $L_{\mathfrak{Z}}$ has no function or constant symbols;
- there is a symbol $Z \in L_{\mathfrak{Z}}$ that is interpreted as \mathbb{Z} in \mathfrak{Z} ;
- $\text{Th}(\mathfrak{Z})$ has QE;
- \mathfrak{Z} defines $<$ and $|$ (hence also all arithmetic sets).

Put $L = L'_{\mathbb{Q}} \cup L_{\mathfrak{Z}}$ and $T = T'_{\mathbb{Q}} \cup \{\forall x (Zx \leftrightarrow \lfloor x \rfloor = x)\} \cup \{\sigma^Z : \sigma \in \text{Th}(\mathfrak{Z})\}$, where σ^Z denotes the relativization of σ to Z (see, e.g., [2] for a definition). We will show that T has QE. The proof is an extension of that of the corresponding result for $T'_{\mathbb{Q}}$, but the added complication justifies outlining some details. We begin by disposing of a number of routine technical observations and lemmas (the proofs of which we leave mostly to the reader). Unless indicated otherwise, “term” means “ L -term.”

Every term is a finite composition of $\lfloor \cdot \rfloor$ and $L_{\mathbb{Q}}$ -terms. Every finite composition of $\lfloor \cdot \rfloor$ is T -equivalent to $\lfloor \cdot \rfloor$. Every $L_{\mathbb{Q}}$ -term in variables x_1, \dots, x_n is $T_{\mathbb{Q}}$ -equivalent to one of the form $\sum_{i=1}^n \lambda_{q_i} x_i + \lambda_{q_0} 1$ for some $n \in \mathbb{N}$ and $q_1, \dots, q_n \in \mathbb{Q}$; we tend to write $\sum_{i=1}^n q_i x_i + q_0$ instead of $\sum_{i=1}^n \lambda_{q_i} x_i + \lambda_{q_0} 1$. If τ_1 and τ_2 are $L_{\mathbb{Q}}$ -terms in variables x_1, \dots, x_n , then there is an $L_{\mathbb{Q}}$ -term σ in the same variables such that

$$\begin{aligned} T_{\mathbb{Q}} \vdash \tau_1 x_1 \cdots x_n = \tau_2 x_1 \cdots x_n &\leftrightarrow \sigma x_1 \cdots x_n = 0, \\ T_{\mathbb{Q}} \vdash \tau_1 x_1 \cdots x_n < \tau_2 x_1 \cdots x_n &\leftrightarrow \sigma x_1 \cdots x_n < 0. \end{aligned}$$

In what follows, we tend to let \mathfrak{B} (allowing subscripts) denote an arbitrary model of T , with underlying set B (allowing corresponding subscripts). Let $Z(\mathfrak{B})$ denote the interpretation of the symbol Z in \mathfrak{B} . Note that $Z(\mathfrak{B}) = \{b \in B : \lfloor b \rfloor = b\}$. We recall a lemma used in the proof of QE of $T'_{\mathbb{Q}}$, restated for our current purposes, followed by some routine consequences.

2.3. For all $b \in Z(\mathfrak{B})$ and positive integers m there exists a unique $i \in \{0, \dots, m - 1\}$ such that $\frac{1}{m}(b + i) \in Z(\mathfrak{B})$.

2.4. Let $n \geq 1$ and $\tau(x_1, \dots, x_n)$ be a term.

1. There is a finite partition \mathcal{C} of $Z(\mathfrak{B})$ into sets \emptyset -definable in the reduct of \mathfrak{B} to $L_{\mathfrak{Z}}$ such that, for each $C \in \mathcal{C}$, there exist $q \in \mathbb{Q}$ and a term $\sigma(x_1, \dots, x_{n-1})$

¹Some minor errors in the published proof were noticed and repaired by Trent Ohl while he was a Ph.D. student of author Miller.

with $\tau = \sigma + qx_n$ on $B^{n-1} \times C$. (More precisely: The restriction to $B^{n-1} \times C$ of the interpretation of τ in \mathfrak{B} is equal to the restriction to $B^{n-1} \times C$ of the interpretation of $\sigma + qx_n$ in \mathfrak{B} .)

2. There is a finite partition \mathcal{C} of $Z(\mathfrak{B})$ into sets \emptyset -definable in the reduct of \mathfrak{B} to L_3 such that, for each $C \in \mathcal{C}$, there exist $q, r \in \mathbb{Q}$ and a term $\sigma(x_1, \dots, x_{n-1})$ such that for all $(b, c) \in B^{n-1} \times C$, if $\tau(b, c) \in Z(\mathfrak{B})$, then $\tau(b, c) = \sigma(b) + qc + r$ and both $\sigma(b)$ and $qc + r$ lie in $Z(\mathfrak{B})$.
3. Let $m \leq n$, $b \in B^m$ and D be the definable closure of b in the reduct of \mathfrak{B} to $L'_\mathbb{Q}$. There is a finite partition \mathcal{C} of $[0, 1)^{n-m}$ into sets that are D -definable in the reduct of \mathfrak{B} to $L_\mathbb{Q}$ such that, for each $C \in \mathcal{C}$, there exist $q_1, \dots, q_{n-m} \in \mathbb{Q}$ and $d, e \in D$ with $\tau(\{b\} \times C) = \sum_{i=m+1}^n q_i x_i + d$ and $\lfloor \tau \rfloor(\{b\} \times C) = e$.

We omit proofs. (Generally, proceed via 2.3 and induction on terms, noting that the interesting cases tend to be when τ is of the form $\lfloor \phi \rfloor$.)

2.5. Every subset of $Z(\mathfrak{B})^n$ that is quantifier-free definable in $(\mathfrak{B}, (b)_{b \in B})$ is definable in $(Z(\mathfrak{B}), (R(\mathfrak{B}))_{R \in L_3})$, where $R(\mathfrak{B})$ is the interpretation of R in \mathfrak{B} .

SKETCH OF PROOF. As every arithmetic set is \emptyset -definable in \mathfrak{Z} , there is a bijection from $Z(\mathfrak{B})^n$ to $Z(\mathfrak{B})$ that is quantifier-free definable in \mathfrak{B} . Thus, it suffices to consider subsets of $Z(\mathfrak{B})$ that are atomically defined in $(\mathfrak{B}, (b)_{b \in B})$. Functions given by unary terms of $(\mathfrak{B}, (b)_{b \in B})$ are given by compositions of $\lfloor \]$ and functions of the form $qx + b$ with $b \in B$. Employ 2.4.1 and 2.4.2 as needed. \dashv

2.6. Let $Y \subseteq B^{m+n}$ be quantifier-free definable in \mathfrak{B} and $(u, z) \in B^m \times Z(\mathfrak{B})^n$. Let D be the definable closure of (u, z) in the reduct of \mathfrak{B} to $L'_\mathbb{Q}$. Then

$$\{x \in B^n : (u, x) \in Y\} \cap \prod_{i=1}^n [z_i, z_i + 1)$$

is D -definable in the reduct of \mathfrak{B} to $L_\mathbb{Q}$.

SKETCH OF PROOF. It suffices to show the result for atomically defined sets. Employ 2.4.3. \dashv

2.7. T is complete and has QE.

PROOF. As the L -structure $(\mathbb{Q}, <, +, 0, 1, (\lambda_q)_{q \in \mathbb{Q}}, \lfloor \], \mathfrak{Z})$ embeds into every model of T , it is enough to show that T has QE. We employ one of the standard “embedding tests.” Let $\mathfrak{B}_1, \mathfrak{B}_2 \models T$ and \mathfrak{A} (with underlying set A) be a substructure of \mathfrak{B}_1 that is also embedded into \mathfrak{B}_2 . Assume that \mathfrak{B}_2 is $\text{card}(B_1)^+$ -saturated. We show that the embedding extends to an embedding of \mathfrak{B}_1 into \mathfrak{B}_2 .

We first reduce to the case that $Z(\mathfrak{B}_1) = Z(\mathfrak{A})$ as follows. Suppose there exists $c_1 \in Z(\mathfrak{B}_1) \setminus Z(\mathfrak{A})$; we show that we may replace \mathfrak{A} with the substructure of \mathfrak{B}_1 generated over \mathfrak{A} by c_1 . (Then iterate as needed.) In order to reduce clerical clutter, let us assume that the embedding of \mathfrak{A} into \mathfrak{B}_2 is just the identity on A . As $\text{Th}(\mathfrak{Z})$ has QE, there exists $c_2 \in B_2$ such that the L_3 -type of c_2 over $A \cap Z(\mathfrak{B}_2)$ is equal to the L_3 -type of c_1 over $A \cap Z(\mathfrak{B}_1)$. It suffices now to show that the quantifier-free L -type of c_2 over A is equal to the quantifier-free L -type of c_1 over A . We illustrate by dealing with a special case. Let: m and n be positive integers; τ be an n -ary term; $a \in A^{n-1}$; R be an m -ary relation symbol of L_3 ; and $a' \in A^{m-1}$. It follows from 2.4.3.

applied to each of \mathfrak{B}_1 and \mathfrak{B}_2 that if $\mathfrak{B}_1 \models R(\tau(a, c_1), a')$, then $\mathfrak{B}_2 \models R(\tau(a, c_2), a')$. (Other cases are handled similarly using 2.4.1 or 2.4.2.)

Now assume that $Z(\mathfrak{B}_1) = Z(\mathfrak{A})$ and let $c_1 \in B \setminus A$. As $T'_\mathbb{Q}$ has QE, there exists $c_2 \in B_2$ such that the $L'_\mathbb{Q}$ -type of c_2 over the image of A (under the embedding) is equal to the $L'_\mathbb{Q}$ -type of c_1 over A . The rest of the proof is similar to (but easier than) the previous case. We omit details. \dashv

PROOF OF PROPOSITION 1.8. Suppose that \mathfrak{R} is an expansion of $(\mathbb{R}, <, +, |)$ by subsets of various \mathbb{N}^n . By passing to an extension by definitions, we assume that $\mathfrak{R} = (\mathbb{R}, <, +, 0, 1, (qx)_{q \in \mathbb{Q}}, \lfloor \cdot \rfloor, \mathfrak{Z})$ where \mathfrak{Z} is the expansion of \mathbb{Z} by all subsets of each \mathbb{Z}^n that are \emptyset -definable in \mathfrak{R} . (*Remark:* By 2.5, every definable subset of any \mathbb{Z}^n is \emptyset -definable, and so \mathfrak{Z} is equal to the structure induced on \mathbb{Z} in \mathfrak{R} .) By 2.7, $\text{Th}(\mathfrak{R})$ has QE and is axiomatized by T . By QE and 2.6, every bounded set definable in \mathfrak{R} is definable in $(\mathbb{R}, <, +)$, i.e., Proposition 1.8.1 holds; then Proposition 1.8.2 is immediate via 2.2. It remains to show that \mathfrak{R} is CC.

Let $E \subseteq \mathbb{R}^n$ be definable in \mathfrak{R} . We must show that each component of E is definable. Let $m \in \mathbb{N}$, $c \in \mathbb{R}^m$ and $X \subseteq \mathbb{R}^{m+n}$ be \emptyset -definable in \mathfrak{R} such that $E = \{e \in \mathbb{R}^n : (c, e) \in X\}$. Via QE, 2.5, 2.1 and model-theoretic compactness, there exist

- $N \in \mathbb{N}$,
- sets $Y_1, \dots, Y_N \subseteq \mathbb{R}^{m+n}$ that are \emptyset -definable in $(\mathbb{R}, <, +, 1)$,
- maps $F_1, \dots, F_N : \mathbb{R}^{m+n} \rightarrow \mathbb{R}^m$ that are \emptyset -definable in \mathfrak{R} .

such that, for each $z \in \mathbb{Z}^n$, there exists $J \subseteq \{1, \dots, N\}$ such that the sets

$$\{x \in \mathbb{R}^n : (F_j(c, z), x) \in Y_j\}, \quad j \in J$$

partition $E \cap \prod_{k=1}^n [z_k, z_k + 1)$ into cells of $(\mathbb{R}, <, +)$. The set of all $z \in \mathbb{Z}^n$ such that $\prod_{k=1}^n [z_k, z_k + 1)$ intersects E is definable in \mathfrak{R} , and the possible descriptions of the cells in $E \cap \prod_{k=1}^n [z_k, z_k + 1)$ can be coded uniformly in z by subsets of $\{0, 1\}^d$ for some $d \in \mathbb{N}$. Thus, there exist $m \in \mathbb{N}$ and definable $S \subseteq \mathbb{Z}^m \times \mathbb{R}^n$ such that, letting A be the projection of S on the first m coordinates, the fibers $S_a (= \{e \in \mathbb{R}^n : (a, e) \in S\})$ of S over A partition E into connected sets that are each definable in $(\mathbb{R}, <, +)$. As any expansion of $(\mathbb{Z}, <, \{0\})$ has Definable Choice, we reduce to the case that $a \mapsto S_a$ is injective. Let G be the set of all pairs $(a, b) \in A^2$ such that $(S_a \cap \overline{S_b}) \cup (S_b \cap \overline{S_a}) \neq \emptyset$; then G is definable in \mathfrak{R} , hence also in \mathfrak{Z} . As \mathfrak{Z} defines all arithmetic sets, each graph component of (A, G) is definable in \mathfrak{Z} . (To put this another way: Since G is computable from A , each graph component of (A, G) is computably enumerable from A , hence definable in $(\mathbb{Z}, +, \cdot, A)$.) It is an exercise (cf. [5, Chapter 3, (2.19).5]) to see that C is a graph component of (A, G) if and only if $\bigcup_{a \in C} S_a$ is a component of E . \dashv

§3. Concluding remarks. Examination of the proof of Proposition 1.8 yields a number of other results; below are three illustrative examples.

3.1. Let \mathfrak{R} be an expansion of $(\mathbb{R}, <, +, 1, \mathbb{Z})$ by subsets of various \mathbb{Z}^n . Then $\text{Th}(\mathfrak{R})$ is axiomatized over the union of $\text{Th}(\mathbb{R}, <, +, 1)$ and the relativization to \mathbb{Z} of the theory of the structure induced on \mathbb{Z} in \mathfrak{R} by expressing that $(\mathbb{Z}, +, 1)$ is a substructure of $(\mathbb{R}, +, 1)$ and, for every $r \in \mathbb{R}$, there is a unique $k \in \mathbb{Z}$ such that $k \leq r < k + 1$.

3.2. If \mathfrak{R}_0 is a reduct in the sense of definability of $(\mathbb{R}, <, +)$ over $(\mathbb{R}, <)$, and \mathfrak{R} is an expansion of $(\mathfrak{R}_0, \mathbb{N})$ by subsets of various \mathbb{N}^n , then \mathfrak{R} is PCC, CC or QCC if and only if it defines $|$.

(For the QE, replace \mathfrak{R}_0 with the expansion in the syntactic sense of $(\mathbb{R}, <, 0, 1)$ by all $\{0, 1\}$ -definable functions of \mathfrak{R}_0 . Every such function is \emptyset -definable in $(\mathbb{R}, <, +, 1)$.)

3.3. Let G be a divisible additive subgroup of \mathbb{R} containing 1 and \mathfrak{G} be an expansion of $(G, <, +, \mathbb{Z})$ by subsets of various \mathbb{Z}^n . If \mathfrak{G} defines $|$, then for all $E \subseteq G^n$ definable in \mathfrak{G} and $x \in E$, \mathfrak{G} defines the set of $y \in E$ for which there is a definable-in- $(G, <, +)$ continuous map $\gamma: [a, b] \rightarrow E$ such that $\gamma(a) = x$ and $\gamma(b) = y$.

(The appropriate analogue of 2.2 follows from [5, p. 100].)

We now return to a question hinted at in the introduction: To what extent does Proposition 1.5 depend on working over \mathbb{R} ?

The notion of PCC is problematic in more general settings. The usual definition of “path” includes the requirement that the domain of a path be a compact subinterval of \mathbb{R} , and in practice, one typically uses that $-x$ is an order-reversing bijection of \mathbb{R} and all infinite compact intervals are definably isomorphic in the vector space $(\mathbb{R}, +, (rx)_{r \in \mathbb{R}})$. We can get around this in some special settings. Let $(M, <)$ be a linear order. If $X \subseteq M^n$, then we say that a path in X , relative to $(M, <)$, is a continuous map f from an interval $[a, b]$ into M^n such that $f([a, b]) \subseteq X$, and declare a piecewise path in X (relative to $(M, <)$) to be a finite sequence

$$\gamma := (\gamma_1: [a_1, b_1] \rightarrow M^n, \dots, \gamma_{p+1}: [a_{p+1}, b_{p+1}] \rightarrow M^n)$$

of paths in X (for some $p \in \mathbb{N}$) such that $\gamma_k(b_k) = \gamma_{k+1}(a_{k+1})$ for $k = 1, \dots, p$. We say that γ is injective if each γ_j is injective and the images $\gamma([a_1, b_1]), \dots, \gamma([a_p, b_p]), \gamma([a_{p+1}, b_{p+1}])$ are pairwise disjoint. The image of γ is the union of the images of the γ_k . We abuse terminology somewhat and say that X is path connected relative to $(M, <)$ if for all $u, v \in X$ there is a piecewise path γ in X such that u and v are contained in the image of γ . If the piecewise paths can be taken to be injective, then we say that X is injectively path connected relative to $(M, <)$. Now fix an expansion \mathfrak{M} of $(M, <)$ and $A \subseteq M$. We can specialize these definitions to the notion “ A -definable in \mathfrak{M} ” in a mostly obvious fashion. (Some authors might require that X be A -definable in order to call it A -definably path connected relative to \mathfrak{M} , but we do not.) If $A = M$, then we omit mention of A . (Thus, definably path connected relative to $(\mathbb{R}, <, +, \cdot, \mathbb{N})$ is the same as path connected in the usual sense.) An examination of the proof of Proposition 1.5 yields the following technical result, thus establishing that working over \mathbb{R} is not necessary if one is willing to modify a few definitions.

3.4. Let D be a dense subset of \mathbb{R} that contains \mathbb{N} . Let $A \subseteq D$ and \mathfrak{D} be an expansion of $(D, <, \mathbb{N})$ such that for all $E \subseteq F \subseteq D^7$, if F is \emptyset -definable in $(D, <, \mathbb{N})$ and E is maximally \emptyset -definably injectively path connected relative to $(D, <, (n)_{n \in \mathbb{N}})$, then E is A -definable in \mathfrak{D} . Then $|$ is A -definable in \mathfrak{D} .

(A priori, the hypothesis is weaker than PCC for expansions of $(\mathbb{R}, <)$. We leave nonarchimedean settings to the interested reader.)

As an application, we obtain the converse of 3.3, hence also the following extension of Theorem 1.9.

3.5. Let G be a divisible subgroup of \mathbb{R} containing 1 and \mathfrak{G} be an expansion of $(G, <, +, \mathbb{Z})$ by subsets of various \mathbb{Z}^n . Then \mathfrak{G} defines $|$ if and only if for all E definable in \mathfrak{G} and $x \in E$, \mathfrak{G} defines the set of all $y \in E$ for which there is a definable-in- $(G, <, +)$ continuous map $\gamma: [a, b] \rightarrow E$ such that $\gamma(a) = x$ and $\gamma(b) = y$.

As we have defined it, the notion of CC is of little use in more general settings, even for o-minimal expansions of dense linear orders. To illustrate, every expansion of a totally disconnected linear order is trivially CC. However, there is a natural generalization of the notion of CC to first-order topological structures (as defined in [19]): Every definable set A should be a union of definable sets C that are maximal with respect to the property of not being disconnected by any pair of definable open sets. In [5], such sets C are called definably connected components of A (and are definable *by definition*).

In o-minimal structures, all definable sets are unions of finitely many definably connected components [5, p. 57]. But by QE of $\text{Th}(\mathbb{R}, <)$, there is no piecewise path definable in $(\mathbb{R}, <)$ joining any point in $(-\infty, 1) \times (-\infty, 2)$ to the point $(1, 2)$. Thus, in $(\mathbb{R}, <)$, the set $(-\infty, 1) \times (-\infty, 2) \cup \{(1, 2)\}$ is path connected and definably connected, but not definably path connected relative to $(\mathbb{R}, <)$.

Let \mathfrak{M} be as before. Under any reasonable definition, M should be regarded as \emptyset -definably injectively path connected in \mathfrak{M} —but M need not be definably connected in \mathfrak{M} , even if $(M, <)$ is densely ordered (say, if \mathfrak{M} is weakly o-minimal, but not o-minimal). This failure of the fundamental topological fact that path connectedness implies connectedness invalidates many of the techniques used in our arguments over $(\mathbb{R}, <)$. However, it is known that if $(M, <)$ is densely ordered and M is definably connected in \mathfrak{M} , then the implication is essentially restored for definable data. Hence, we have the following corollary of 3.4, the proof of which we leave as an exercise (familiarity with some results in [12] will be needed).

3.6. Let D be a dense subset of \mathbb{R} that contains \mathbb{N} . Let \mathfrak{D} be an expansion of $(D, <, \mathbb{N})$ such that D is definably connected in \mathfrak{D} and every definable set is a union of definably connected components. Then $|$ is definable in \mathfrak{D} .

In particular, if \mathfrak{R} is an expansion of $(\mathbb{R}, <, \mathbb{N})$ such that every definable set is a union of definably connected components (an a priori weaker condition than CC), then $|$ is definable.

We leave any potential generalizations of QCC to the interested reader.

Acknowledgments. Research of Dolich was funded in part by PSC-CUNY Grant 61234-00 49. Research of Miller was funded in part by a Simons Visiting Professorship, hosted by Mathematisches Forschungsinstitut Oberwolfach, Universität Konstanz, and Université Savoie Mont Blanc (Bourget-du-Lac). Research of Thamrongthanyalak was conducted in part while a Zassenhaus Assistant Professor at Ohio State University. We thank David Marker, Russell Miller, Serge Randriambololona, Charles Steinhorn and Erik Walsberg for helpful observations.

REFERENCES

- [1] M. ASCHENBRENNER and A. THAMRONGTHANYALAK, *Michael's selection theorem in a semilinear context*. *Advances in Geometry*, vol. 15 (2015), no. 3, pp. 293–313.
- [2] C. C. CHANG and H. J. KEISLER, *Model Theory*, third ed., Studies in Logic and the Foundations of Mathematics, 73, North-Holland Publishing Co., Amsterdam, 1990.
- [3] A. DOLICH, C. MILLER, and C. STEINHORN, *Structures having o -minimal open core*. *Transactions of the American Mathematical Society*, vol. 362 (2010), no. 3, pp. 1371–1411.
- [4] R. DOUGHERTY and C. MILLER, *Definable Boolean combinations of open sets are Boolean combinations of open definable sets*. *Illinois Journal of Mathematics*, vol. 45 (2001), no. 4, pp. 1347–1350.
- [5] L. VAN DEN DRIES, *Tame Topology and O -Minimal Structures*, London Mathematical Society Lecture Note Series, 248, Cambridge University Press, Cambridge, 1998.
- [6] L. VAN DEN DRIES and C. MILLER, *Geometric categories and o -minimal structures*. *Duke Mathematical Journal*, vol. 84 (1996), no. 2, pp. 497–540.
- [7] A. FORNASIERO, *Definably connected nonconnected sets*. *Mathematical Logic Quarterly*, vol. 58 (2012), no. 1–2, pp. 125–126.
- [8] H. FRIEDMAN and C. MILLER, *Expansions of o -minimal structures by sparse sets*. *Fundamenta Mathematicae*, vol. 167 (2001), no. 1, pp. 55–64.
- [9] ———, *Expansions of o -minimal structures by fast sequences*, this JOURNAL vol. 70 (2005), no. 2, pp. 410–418.
- [10] T. KAWAKAMI, K. TAKEUCHI, H. TANAKA, and A. TSUBOI, *Locally o -minimal structures*. *Journal of the Mathematical Society of Japan*, vol. 64 (2012), no. 3, pp. 783–797.
- [11] G. LAFFERRIERE and C. MILLER, *Uniform Reachability Algorithms*, Proceedings of the Hybrid Systems: Computation and Control, 3rd International Workshop, HSCC2000, Pittsburgh, PA, USA, March 23–25, 2000, Springer, Berlin, 2000, pp. 215–228.
- [12] C. MILLER, *Expansions of dense linear orders with the intermediate value property*, this JOURNAL vol. 66 (2001), no. 4, pp. 1783–1790.
- [13] ———, *Tameness in expansions of the real field*, *Logic Colloquium '01*, Lecture Notes in Logic, vol. 20, Association for Symbolic Logic, Urbana, IL, 2005, pp. 281–316.
- [14] ———, *Expansions of o -minimal structures on the real field by trajectories of linear vector fields*. *Proceedings of the American Mathematical Society*, vol. 139 (2011), no. 1, pp. 319–330.
- [15] C. MILLER and A. THAMRONGTHANYALAK, *Component-closed expansions of the real line (preliminary report)*. *Structures algébriques ordonnées*, Équipe de Logique Mathématique, Université Paris Diderot, Paris, 2018.
- [16] ———, *D -minimal expansions of the real field have the zero set property*. *Proceedings of the American Mathematical Society*, vol. 146 (2018), no. 12, pp. 5169–5179.
- [17] C. MILLER and J. TYNE, *Expansions of o -minimal structures by iteration sequences*. *Notre Dame Journal of Formal Logic*, vol. 47 (2006), no. 1, pp. 93–99.
- [18] J. R. MUNKRES, *Topology: A First Course*, Prentice-Hall, Inc., Englewood Cliffs, NJ, 1975.
- [19] A. PILLAY, *First order topological structures and theories*, this JOURNAL vol. 52 (1987), no. 3, pp. 763–778.
- [20] J. ROBINSON, *Definability and decision problems in arithmetic*, this JOURNAL vol. 14 (1949), pp. 98–114.
- [21] A. SAVATOVSKY, *Structure theorems for d -minimal expansions of the real additive ordered group and some consequences*, Ph.D. thesis, University of Konstanz, 2020.
- [22] S. SOKANTIKA and A. THAMRONGTHANYALAK, *Definable continuous selections of set-valued maps in o -minimal expansions of the real field*. *Bulletin of the Polish Academy of Sciences Mathematics*, vol. 65 (2017), no. 2, pp. 97–105.
- [23] A. THAMRONGTHANYALAK, *Dimensional coincidence does not imply measure-theoretic tameness*. *Fundamenta Mathematicae*, vol. 242 (2018), no. 1, pp. 103–107.
- [24] ———, *Michael's selection theorem in d -minimal expansions of the real field*. *Proceedings of the American Mathematical Society*, vol. 147 (2019), no. 3, pp. 1059–1071.
- [25] M. A. TYCHONIEVICH, *Tameness results for expansions of the real field by groups*, Ph.D. thesis, The Ohio State University, 2013.

DEPARTMENT OF MATHEMATICS AND COMPUTER SCIENCE
KINGSBOROUGH COMMUNITY COLLEGE
2001 ORIENTAL BOULEVARD
BROOKLYN, NY 11235, USA

and

DEPARTMENT OF MATHEMATICS
THE GRADUATE CENTER
365 FIFTH AVENUE
ROOM 4208
NEW YORK, NY 10016, USA

E-mail: alfredo.dolich@kbcc.cuny.edu

DEPARTMENT OF MATHEMATICS
OHIO STATE UNIVERSITY
231 WEST 18TH AVENUE
COLUMBUS, OH 43210, USA

E-mail: miller@math.ohio-state.edu

DEPARTMENT OF MATHEMATICS AND STATISTICS
UNIVERSITY OF KONSTANZ
78457 KONSTANZ, GERMANY

Current address:

DEPARTMENT OF MATHEMATICS, FACULTY OF NATURAL SCIENCES
UNIVERSITY OF HAIFA
199 ABBA KHOSHAY AVENUE
MOUNT CARMEL, HAIFA, 3498838, ISRAEL

E-mail: alex@savatovsky.net

DEPARTMENT OF MATHEMATICS
OHIO STATE UNIVERSITY
231 WEST 18TH AVENUE
COLUMBUS, OH 43210, USA

Current address:

DEPARTMENT OF MATHEMATICS AND COMPUTER SCIENCE
FACULTY OF SCIENCE
CHULALONGKORN UNIVERSITY
BANGKOK, 10330, THAILAND

E-mail: athipat.th@chula.ac.th