

Original Article

Cite this article: So SHo-wai, Chung LKin-hei, Tse Chun-Yu, Chan SSau-man, Chong GHeung-chuen, Hung KShee-yueng, Sommer IEC (2021). Moment-to-moment dynamics between auditory verbal hallucinations and negative affect and the role of beliefs about voices. *Psychological Medicine* **51**, 661–667. <https://doi.org/10.1017/S0033291719003611>

Received: 15 August 2019

Revised: 12 November 2019

Accepted: 22 November 2019

First published online: 7 January 2020

Key words:

Affect; auditory verbal hallucinations; beliefs about voices; cognitive models; experience sampling; psychosis

Author for correspondence:

Suzanne Ho-wai So,
E-mail: shwso@psy.cuhk.edu.hk

Moment-to-moment dynamics between auditory verbal hallucinations and negative affect and the role of beliefs about voices

Suzanne Ho-wai So¹ , Lawrence Kin-hei Chung¹, Chun-Yu Tse¹, Sandra Sau-man Chan², George Heung-chuen Chong³, Karen Shee-yueng Hung⁴ and Iris E. C. Sommer⁵

¹Department of Psychology, The Chinese University of Hong Kong, New Territories, Hong Kong SAR, China; ²Department of Psychiatry, The Chinese University of Hong Kong, New Territories, Hong Kong SAR, China; ³Clinical Psychology Service, Kwai Chung Hospital, Kowloon, Hong Kong SAR, China; ⁴Department of Psychiatry, Castle Peak Hospital, New Territories, Hong Kong SAR, China and ⁵Department of Neuroscience and Department of Psychiatry, University Medical Center Groningen, The University of Groningen, Groningen, The Netherlands

Abstract

Background. Negative affect (NA) has been suggested to be both an antecedent and a consequence of auditory verbal hallucinations (AVH). Furthermore, negative appraisals of voices have been theorized to contribute to the maintenance of AVH. Using the experience sampling method (ESM), this study examined the bi-directional relationship between NA and AVH, and the moderating effect of negative beliefs about voices.

Methods. Forty-seven patients diagnosed with schizophrenia spectrum disorders with frequent AVH completed a clinical interview, followed by ESM for 10 times a day over 6 days on an electronic device. Time-lagged analyses were conducted using multilevel regression modeling. Beliefs about voices were assessed at baseline.

Results. A total of 1654 data points were obtained. NA predicted an increase in AVH in the subsequent moment, and AVH predicted an increase in NA in the subsequent moment. Baseline beliefs about voices as malevolent and omnipotent significantly strengthened the association between NA and AVH within the same moment. In addition, the belief of omnipotence was associated with more hallucinatory experiences in the moment following NA. However, beliefs about voices were not associated directly with momentary levels of NA or AVH.

Conclusions. Experiences of NA and AVH drove each other, forming a feedback loop that maintained the voices. The associations between NA and AVH, either within the same moment or across moments, were exacerbated by negative beliefs about voices. Our results suggest that affect-improving interventions may stop the feedback loop and reduce AVH frequency.

Introduction

Auditory verbal hallucinations (AVH), experiences of hearing voices without external stimuli, affect 75% of patients with schizophrenia (Waters & Fernyhough, 2017). Within this group, 25–30% of individuals experienced persistent AVH despite antipsychotic medication (Kane, Honigfeld, Singer, & Meltzer, 1988; Meltzer, 1992) and 75% of voice hearers experienced a high level of distress associated with their voices (Copolov, Mackinnon, & Trauer, 2004). Patients with schizophrenia also commonly experienced anxiety and depression, with reported rates of 45% (Badcock, Paulik, & Maybery, 2011; Cosoff & Hafner, 1998; Leff, Tress, & Edwards, 1988; Lysaker & Salyers, 2007; Turnbull & Bebbington, 2001). There is cross-sectional evidence for more frequent and more severe AVH when patients also suffered from depression (Smith et al., 2006; Soppitt & Birchwood, 1997).

It has been proposed that negative emotions are not merely consequences of AVH, but also antecedents of AVH (Allen & Agus, 1968; Slade, 1976). In a semi-structured interview, patients with AVH recalled experiencing sadness, fear, and anger prior to hallucinations (Nayani & David, 1996). A number of longitudinal studies investigating onset and relapse of psychosis also pointed toward a pivotal role of negative emotions in the emergence and exacerbations of positive symptoms (including hallucinations) (see review by Hartley, Barrowclough, & Haddock, 2013). In the prodromal phase of psychosis, there is robust evidence for emotional disturbances to precede transition into psychosis in the majority of cases (see reviews by Birchwood, Macmillan, & Smith, 1992; Broome et al., 2005; Yung & McGorry, 1996).

The temporal relationship between AVH and emotions has been investigated mostly by retrospective methods of measurement, which may be subject to recall bias (Shiffman,

Stone, & Hufford, 2008). Experience sampling methodology (ESM) is a structured diary in the respondents' daily living environment that captures subjective moment-to-moment experiences (see reviews by Fahrenberg, Myrtek, Pawlik, & Perez, 2007; Myin-Germeys et al., 2009, 2018; Scollon, Prieto, & Diener, 2009). As AVH are discrete phenomena with identifiable points of onset and termination (Oorschot et al., 2012) and varying intensity over hours and days (Delepaul, Devries, & van Os, 2002), ESM provides a feasible and reliable tool to address the temporality of AVH and associated mechanisms. Using ESM, Peters et al. (2012a) found that hallucinatory intensity was associated with an increased level of negative affect (NA) and a decreased level of positive affect (PA) within the same moment. An across-moments approach of analysis, however, revealed inconsistent results. Delepaul et al. (2002) found an elevated anxiety level before the onset of hallucinations, which subsided at the end of the hallucinatory episode. Oorschot et al. (2012), in contrast, reported no change in NA before or after occurrence of AVH. More data are needed to clarify the temporal interplay between AVH and affect.

While earlier research suggested that voice hearers' behavioral and emotional responses directly arise from the experience of AVH *per se* (e.g. Benjamin, 1989), recent developments in cognitive models of AVH posit that behavioral and emotional consequences may be exacerbated by the beliefs that voice hearers held about the voices (Birchwood & Chadwick, 1997; Chadwick & Birchwood, 1994, 1995; Morrison & Renton, 2001). Specifically, voices appraised to be evil (malevolent) and powerful (omnipotent) provoke distress and are resisted, whereas voices perceived to have good intentions (benevolent) lead to PA and are engaged (Birchwood & Chadwick, 1997; So & Wong, 2008). While the association between beliefs about voices and emotional distress has been corroborated across studies (Andrew, Gray, & Snowden, 2008; Mawson, Cohen, & Berry, 2010; Peters, Williams, Cooke, & Kuipers, 2012b; van der Gaag, Hageman, & Birchwood, 2003), these studies focused on level of emotional distress rather than change in distress in response to occurrence of AVH. Whether beliefs about voices moderate the temporal associations between hallucinations and NA in real time has not been formally tested. For example, it is possible that individuals who believe their voices to be malevolent may become subsequently more distressed, whereas individuals who believe their voices to be benevolent may choose to initiate a hallucinatory experience when they are upset. Examining the influence of beliefs on the temporal relationship between voices and distress will provide insights on how beliefs, emotions, and hallucinations interact, thereby consolidating the cognitive model of psychosis.

The present study aimed to elucidate the moment-to-moment associations between the intensity of AVH and the level of NA, and the effect of baseline negative beliefs about voices on the moment-to-moment associations, using ESM among patients experiencing frequent AVH.

The key hypotheses were as follows:

- (1) Momentary level of NA will predict the intensity of AVH at the following time point
- (2) Momentary intensity of AVH will predict the level of NA at the following time point
- (3) Baseline beliefs about voices (malevolence, omnipotence, and benevolence) will moderate the moment-to-moment relationships between AVH and NA

Methods

Participants

Ethical approval for this study was granted by the Joint Chinese University of Hong Kong – New Territories East Cluster Clinical Research Ethics Committee (2015.685-T), Kowloon West Cluster Research Ethics Committee [KW/FR-15-216 (94-12)] and New Territories West Cluster Research Ethics Committee (NTWC/CREC/17028). Inclusion criteria were: psychiatric outpatients with present AVH [scoring 3 or above on item P3 hallucinatory behavior of the Positive and Negative Syndrome Scale (PANSS; Kay, Fiszbein, & Opler, 1987)], a diagnosis of schizophrenia spectrum disorder (based on the SCID interview), and aged 18 or above. Exclusion criteria were patients with drug-induced or organic psychosis, a primary diagnosis of substance misuse, and intellectual disability.

Measures

Clinical interview

The Chinese-bilingual Structured Clinical Interview for DSM-IV Axis I Disorders (CB-SCID-I/P; So et al., 2003) is a semi-structured interview-based instrument for obtaining reliable DSM-IV Axis I disorders diagnoses. Good inter-rater and test-retest reliabilities have been reported (So et al., 2003).

Severity of schizophrenia symptoms and hallucinations

Severity of schizophrenia symptoms was assessed by using the PANSS (Kay et al., 1987), with a total score ranging from 30 to 210. Severity of hallucinations was assessed by using the hallucination sub-scales of Scale of Assessment for Positive Symptoms (SAPS; Andreasen, 1984) and the Psychotic Symptom Rating Scales (PSYRATS; Haddock, McCarron, Tarrier, & Faragher, 1999).

Depressive symptoms

Calgary Depression Scale for Schizophrenia (CDSS; Addington, Addington, Maticka-Tyndale, & Joyce, 1992) is a nine-item, four-point (0–3) rating semi-structured interview scale for assessing depressive symptoms in patients with schizophrenia. Each item is anchored by descriptors. CDSS total score ranges from 0 to 27. High internal consistency and strong correlation with other established measures of depression have been reported (Addington et al., 1992).

Anxiety symptoms

The Chinese version of the Beck Anxiety Inventory (BAI; Beck, Epstein, Brown, & Steer, 1988) is a 21-item, four-point (0–3) rating self-report questionnaire that measures anxiety severity and unique symptom features that are independent of that in depression, including somatic symptoms and subjective experience of panic and anxiety. Good reliability and validity of the Chinese version have been reported (Cheng et al., 2002).

Experience sampling method

ESM, a structured self-assessment diary method, was used to measure momentary levels of affect and symptoms (see reviews above). A mobile application was programmed to display the same ESM questionnaire for 10 times a day over 6 days, using a signal-contingent protocol in parallel to our previous ESM studies (see Chan et al., 2019; Leung et al., 2019; So, Peters, Swendsen, Garety, & Kapur, 2013, 2014 for more details). The application

evoked a beep signal at a random time of the day to prompt participants to complete a new ESM entry. Each entry was at least 30 min apart. Care was taken to ensure that the signals would occur within the waking hours of the participants, with 10–12 target hours each day. The questionnaire could only be activated within 15 min after the signal to minimize any preemptive responses, and would otherwise be inaccessible by the participants. The questions were displayed one at a time, and each response was time-stamped. Participants were told to respond as soon as possible upon a signal.

The ESM questionnaire included items on NA and PA, psychotic symptoms, and current activity and environment. NA items measured subjective feelings of 'irritated', 'low', and 'tense', while PA items measured subjective feelings of 'cheerful', 'relaxed', and 'content' (Myin-Germeys, Nicolson, & Delespaul, 2001; Myin-Germeys, Birchwood, & Kwapil, 2011). Each affective item was phrased 'Do you feel...right now?'. High internal consistency of NA (Cronbach's $\alpha = 0.853$) and PA (Cronbach's $\alpha = 0.867$), based on the data on day 1, was achieved. The AVH item was phrased as follows: 'Do you hear voices that other people cannot hear right now?' (Kimhy et al., 2017; Varese, Udachina, Myin-Germeys, Oorschot, & Bentall, 2011). Items on NA, PA, and AVH were rated on seven-point Likert scales, which ranged from one (not at all) to seven (very much).

Beliefs about voices and responses to voices

The Chinese version of the Revised Beliefs about Voices Questionnaire (BAVQ-R; Chadwick, Lees, & Birchwood, 2000) is a 35-item, four-point (0–3) rating self-report questionnaire that consists of three subscales pertaining to beliefs about voices: malevolence (i.e. voices as evil and persecutory), omnipotence (i.e. voices as controlling and powerful), and benevolence (i.e. voices as helpful), with scores of each subscale ranging from 0 to 18, and two subscales pertaining to emotional and behavioral responses to voices: resistance and engagement (four items for emotion and five items for behavior each), with score ranges from 0 to 27 and 0 to 24, respectively. Good internal consistency and test-retest reliability of the Chinese version have been reported (Wong & Chen, 2015).

Procedures

Upon written consent, participants completed the baseline interview conducted by a graduate-level research assistant and trainee clinical psychologists, closely supervised by the first author, and self-report questionnaires. Toward the end of the assessment, participants were trained to use the ESM application on their personal smartphone, or an iPod touch fifth generation (Model A1509) borrowed from the research team. A practice trial was completed with the guidance of a researcher. Participants were encouraged to maintain their daily routine while carrying the mobile devices with them at all times throughout the assessment period. A follow-up phone call was made on the next day. Additional technical support was provided as required. After 6 days, participants returned the device where applicable, and were debriefed.

Statistical analysis

Baseline variables were analyzed using SPSS version 24.0. Multilevel linear regression modeling with maximum likelihood estimation was used to evaluate the association between ESM variables

(Goldstein, 1987). All regression models were tested using the XT MIXED command in STATA 11.2. ESM variables were entered as level-1 variables and participant was entered as a level-2 random-effect variable. In order to capture the mean relation between a patient's time-specific deviation in a certain ESM variable, relative to the overall level of that variable for each patient, repeated ESM variables were group-mean centered (i.e. within each patient). In order to compare the effects of baseline variables across patients, baseline variables such as beliefs about voices were grand-mean centered (i.e. within the entire sample) (Curran & Bauer, 2011; Wang & Maxwell, 2015). As in previous ESM studies (Udachina, Bentall, Varese, & Rowse, 2017; Vaessen et al., 2018; Westermann et al., 2017), participants who completed <30% (i.e. 18 out of 60) of ESM observations were excluded from the analysis.

To model between-moment associations of ESM variables, time-lagged analyses were performed. The effect of the independent variable (IV) at a given moment t (IV_t) on change in the dependent variable (DV) was modeled by regressing DV at the subsequent moment $t + 1$ (DV_{t+1}) on IV_t , controlling for DV at moment t (DV_t). To test the effect of baseline variables (*Malevolence*, *Omnipotence*, *Benevolence*) on the moment-to-moment association between NA and AVH, separate multilevel linear regression models were estimated. With the level of NA as DV, *Malevolence* and *Malevolence* \times *AVH* interaction, *Omnipotence* and *Omnipotence* \times *AVH* interaction, *Benevolence* and *Benevolence* \times *AVH* interaction, along with the level of AVH, were entered as IVs, respectively. With the level of AVH as DV, *Malevolence* and *Malevolence* \times *NA* interaction, *Omnipotence* and *Omnipotence* \times *NA* interaction, *Benevolence* and *Benevolence* \times *NA* interaction, along with the level of NA, were entered as IVs, respectively.

Results

Demographic and clinical data

A total of 54 patients consented to participate in this study. After excluding seven patients who did not meet our inclusion criteria, the final sample consisted of 47 patients, among whom 41 completed at least 18 out of 60 ESM entries and were included in the analysis. There was no significant difference between completers and non-completers in age, gender, years of education, number of psychiatric admissions, or any of the clinical and self-report measures ($p > 0.05$). Four extreme responders for the AVH item of the ESM questionnaire were identified (three reported score of 1 for all entries and one reported score of 7 for all entries). Results did not differ after removing these individuals. Therefore, we kept them in the analysis, and reported results based on a sample of 41 individuals. In total, 1654 data points were obtained. The consecutive ESM moments within the same day were 18.92 to 172.78 min apart (mean = 71.77, s.d. = 24.26).

Table 1 presents the descriptive statistics of the sample ($N = 41$). The average baseline rating of SAPS hallucinations scale score was 14.41 (s.d. = 6.59, range 5–29), PSYRATS auditory hallucinations scale score was 25.49 (s.d. = 7.37, range 9–40), and PANSS item P3 (hallucinatory behavior) was 4.12 (s.d. = 0.81, range 3–6), indicating a moderate to moderate-severe level of severity (Kay et al., 1987). Moreover, the average PSYRATS AVH frequency and duration score were 2.49 (range 1–4) and 2.71 (range 1–4), respectively, indicating an hourly to daily occurrence of AVH that lasted for several minutes to at least an hour (Haddock et al., 1999).

Table 1. Sample characteristics ($N = 41$)

	Mean (s.d.)	Range
Male, number (%)	15 (36.59%)	
Age	43.83 (12.40)	19–64
Year of education	10.88 (2.87)	5–16
No. of psychiatric admissions	3.12 (3.48)	0–20
Dosage in CPZ (mg/day)	564.49 (338.47)	68.00–1631.25
Dosage in HAL (mg/day)	13.94 (8.81)	1.97–43.50
PANSS positive	15.56 (5.59)	9–32
PANSS negative	11.37 (3.99)	7–23
PANSS general psychopathology	25.05 (7.02)	16–45
PANSS total	51.98 (12.93)	33–83
CDSS total	3.51 (3.46)	0–12
BAI total	17.12 (13.02)	0–50

CPZ, chlorpromazine equivalent; HAL, haloperidol equivalent; PANSS, Positive and Negative Syndrome Scale; CDSS, Calgary Depression Scale for Schizophrenia; BAI, Beck Anxiety Inventory.

Average baseline ratings of subscales of BAVQ-R were as follows: Malevolence = 6.32 (s.d. = 4.85, range 0–18), Omnipotence = 7.54 (s.d. = 3.85, range 2–18), Benevolence = 5.02 (s.d. = 5.20, range 0–18), Resistance = 14.83 (s.d. = 6.09, range 0–25), and Engagement = 6.37 (s.d. = 5.77, range 0–19). Given that the assumption of normality is violated, Spearman's ρ was examined. Malevolence and Omnipotence were positively associated with each other [$r_s(39) = 0.50, p = 0.001$] and with Resistance [$r_s(39) = 0.53, p < 0.001$ and $r_s(39) = 0.38, p = 0.015$], respectively, whereas Benevolence was positively associated with Engagement [$r_s(39) = 0.82, p < 0.001$] and negatively associated with Resistance [$r_s(39) = -0.41, p = 0.008$]. Omnipotence was also positively associated with Engagement [$r_s(39) = 0.33, p = 0.037$].

The average ESM compliance rate was 67.20 (s.d. = 20.47, range = 30.00–98.33). The average ratings of ESM items, collapsed across 6 days, were as follows: NA = 2.81 (s.d. = 1.45, range 1–7), PA = 4.11 (s.d. = 1.65, range 1–7), and AVH = 3.00 (s.d. = 2.12, range 1–7). There was no significant change in momentary level of NA ($\beta = -0.013, s.e. = 0.012, p = 0.290$), level of PA ($\beta = -0.015, s.e. = 0.012, p = 0.193$), and intensity of AVH ($\beta = -0.008, s.e. = 0.014, p = 0.568$) over 6 days.

Same-moment associations between NA and AVH

Multilevel linear regression showed that NA_t was significantly and positively associated with AVH_t ($\beta = 0.109, s.e. = 0.022, p < 0.001$). Conversely, PA_t was significantly and negatively associated with AVH_t ($\beta = -0.060, s.e. = 0.021, p = 0.004$). Results did not differ after controlling for baseline CDSS score, BAI score, age, and gender.

Across-moment associations between NA and AVH

Time-lagged analysis showed that NA_t was significantly associated with AVH_{t+1} ($\beta = 0.130, s.e. = 0.034, p < 0.001$). After controlling for AVH_t , the association between NA_t and AVH_{t+1} remained significant ($\beta = 0.077, s.e. = 0.034, p = 0.022$). Therefore, the level of NA predicted both the intensity of and increase in AVH at the

following time point. Results did not differ after controlling for baseline CDSS score, BAI score, emotional content of AVH (on PSYRATS), age, and gender.

Time-lagged analysis showed that AVH_t was significantly associated with NA_{t+1} ($\beta = 0.091, s.e. = 0.026, p < 0.001$). After controlling for NA_t , the association between AVH_t and NA_{t+1} remained significant ($\beta = 0.060, s.e. = 0.026, p = 0.018$). Therefore, the intensity of AVH predicted both the level of and increase in NA at the following time point. Results did not differ after controlling for baseline CDSS score, BAI score, emotional content of AVH (on PSYRATS), age, and gender.

Moderating effect of baseline beliefs about voices (malevolence, omnipotence, and benevolence) on the moment-to-moment associations between NA and AVH

Regression analyses revealed no main effect of Malevolence, Omnipotence, or Benevolence on either NA_t or AVH_t ($p > 0.05$). Main effects of Resistance and Engagement were also non-significant ($p > 0.05$). This indicated that none of the BAVQ-R scores was associated with momentary levels of NA and AVH.

In the model with NA_t as DV, there was a significant interaction effect between Malevolence and AVH_t ($\beta = 0.016, s.e. = 0.005, p < 0.001$), and Omnipotence and AVH_t ($\beta = 0.017, s.e. = 0.006, p = 0.004$). However, there was no significant interaction effect between Benevolence and AVH_t ($\beta = -0.007, s.e. = 0.004, p = 0.067$). This indicated that beliefs about voices as malevolent and omnipotent exacerbated the relationship between AVH and NA within the same moment.

In the model with NA_{t+1} as DV and NA_t as covariate, there was no significant interaction effect between Malevolence and AVH_t ($\beta = -0.008, s.e. = 0.005, p = 0.151$), Omnipotence and AVH_t ($\beta = -0.009, s.e. = 0.007, p = 0.197$), or Benevolence and AVH_t ($\beta = 0.003, s.e. = 0.004, p = 0.551$). This indicated that beliefs about voices did not predict a change in NA at the subsequent time point, following AVH.

In the model with AVH_{t+1} as DV and AVH_t as covariate, there was a significant interaction effect between Omnipotence and NA_t ($\beta = 0.015, s.e. = 0.008, p = 0.046$). However, there was no significant interaction effect between Malevolence and NA_t ($\beta = 0.010, s.e. = 0.007, p = 0.168$), and Benevolence and NA_t ($\beta = -0.008, s.e. = 0.006, p = 0.187$). This indicated that the belief about voices as omnipotent exacerbated an increase in AVH at the subsequent time point, following NA.

Results remained unchanged after controlling for baseline CDSS score, BAI score, age, and gender. The key findings are summarized in Fig. 1 in a schematic manner.

Discussion

The present study employed ESM to reveal the moment-to-moment associations between AVH and NA, and the moderating effect of beliefs about voices on their temporal dynamics, among a group of patients with frequent AVH. Momentary level of AVH predicted an increase in NA at the subsequent moment. Crucially, the momentary level of NA also predicted an increase in AVH at the subsequent moment. These findings remained robust after controlling for baseline demographic characteristics and mood symptoms. This demonstrated, to our knowledge the first time, a bi-directional relationship between AVH and NA, whereby patients following a hallucinatory episode experienced

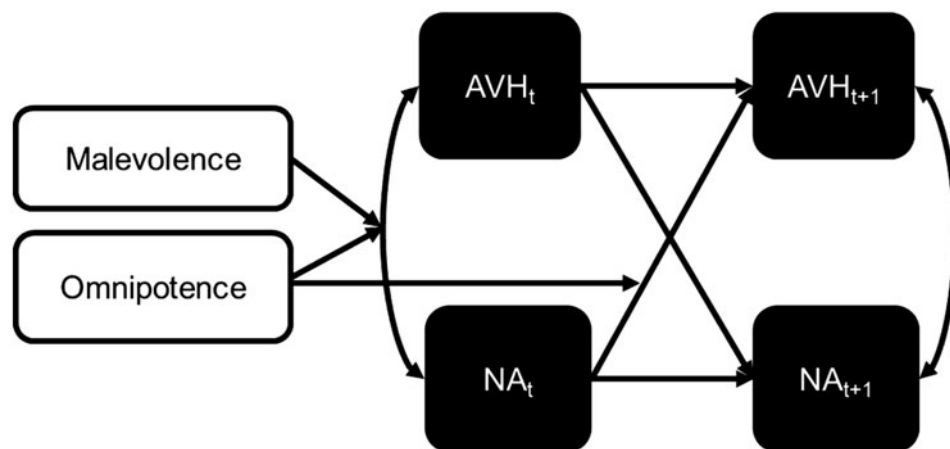

Fig. 1 Schematic diagram illustrating relationships between variables within and across time points. All relationships shown are positive.

more NA that further triggered subsequent hallucinations, leading to a perpetual negative feedback loop.

This study added to the current ESM literature on AVH and emotions in several ways. Firstly, we replicated Peters et al.'s (2012a) finding of a positive association between AVH and negative emotions within the same moment, and further revealed that such positive association was also true across moments. Secondly, rather than setting an arbitrary threshold of a 'hallucinatory episode' like Delespaul et al. (2002) and Oorschot et al. (2012), we treated the severity of AVH as a continuous variable which allowed for greater statistical power and sensitivity to examine variations across time points. Thirdly, we included multiple NA items and adopted an aggregate score rather than restricted to one single emotion (e.g. anxiety, Delespaul et al., 2002). This is supported by previous ESM studies (Kimhy et al., 2006; Myin-Germeys, Delespaul, & van Os, 2005; So et al., 2013) where a high correlation between the NA items was consistently reported.

Mapping out the vicious cycle between AVH and negative emotions carries treatment implications. In cognitive behavioral therapy for psychosis (CBTp), individuals are typically asked to identify triggers and situations that are associated with higher or lower severity of AVH, a procedure called functional analysis (van der Gaag, Valmaggia, & Smit, 2014). Individuals are also encouraged to identify behavioral and emotional responses to AVH, and how they in turn lead to more AVH (Tarrier et al., 1993; Thomas et al., 2014). In addition to recent ESM studies (Chan et al., 2019; Kimhy et al., 2017; Leung et al., 2019; So et al., 2013, 2014), we have demonstrated the feasibility and reliability of mapping out moment-to-moment dynamics between symptoms and subjective experiences. This indicates that ESM, with assistance from a therapist, can be used more routinely in clinical practice to assist patients' understanding of their illness and to facilitate illness management (Bell, Lim, Rossell, & Thomas, 2017; Bell et al., 2018a, 2018b; Myin-Germeys et al., 2011; Simons et al., 2017; van Os et al., 2017). Our results further suggest that activities to lift affect may be effective in reducing the frequency and severity of AVH. Indeed, singing and physical activity have frequently been described as effective coping strategies (Carter, Mackinnon, & Copolov, 1996).

Consistent with Peters et al. (2012b) and others, we found that, at baseline, beliefs about voices as malevolent and omnipotent were associated with resistance of voices, whereas the belief about voices as benevolent was associated with engagement

with voices. However, we found omnipotence to also be significantly associated with engagement with voices. Although beliefs about voices were not significantly associated with momentary levels of NA or AVH, omnipotence was associated with subsequent increase in hallucinatory experiences following NA. Our result is in line with van der Gaag et al.'s (2003) argument of differential effects of the two types of beliefs about voices (malevolence and omnipotence). Believing one's voices as powerful (omnipotent) may or may not lead to resistance against the voices, but what matters to a resistant response is when the power is interpreted as carrying a bad intention. Considering the potential collinearity between malevolence and omnipotence on NA, we conducted a post-hoc test of Malevolence \times Omnipotence interaction. We found no significant interaction effect. Our results raised the possibility that, for some patients who believe their voices to be powerful, they may engage with voices more in times when they are in distress. Indeed, Hacker, Birchwood, Tudway, Meaden, and Amphlett (2008) found that individuals who believed their voices as omnipotent engaged more frequently in safety-seeking behaviors, which included conversing with their voices. These suggest that the relationship between beliefs about voices and engagement/resistance may be less straightforward than previously expected, which warrants further research.

There are several limitations to this study. Firstly, beliefs about voices were only assessed once at baseline. Although appraisals about hallucinations were assumed to be habitual (Csipke & Kinderman, 2006), Peters et al. (2012a) reported that beliefs about power and control of voices may fluctuate across moments. This may explain the absence of associations between beliefs about voices and momentary AVH and NA. The one-time assessment of beliefs about voices in the present study also did not allow us to test for mediation effects. Secondly, although the focus of this study was voices, other co-occurring psychotic symptoms (such as visual hallucinations, delusions, and negative symptoms) may have convoluted the relationships between affect and AVH, and factors such as life events and emotional processing may also affect hallucinatory experiences in ways that we did not measure (Larøi et al., 2019). Thirdly, the random-signal contingency led to varying duration between beeps. We are unsure whether the results would be different if the duration was consistent, or that any between-moment relationships may have been lost due to the duration being too long or too short.

This study demonstrated a vicious cycle between hallucinatory experiences and emotional experiences, which occur in real time

in the flow of daily life among patients with drug-resistant hallucinations. How an individual interprets the power and intent of their voices has an impact on their hallucinatory experiences and emotions. The interaction between hallucinations, emotions, and beliefs about voices reported in this study is consistent with cognitive models of psychosis and may inform CBTp.

Acknowledgements. We would like to thank the participants for giving up their time to take part in this project.

Financial support. This work was supported by the Health and Medical Research Fund, the Food and Health Bureau, The Government of the Hong Kong Special Administrative Region (grant number 13140131).

Conflict of interest. None.

Ethical standards. The authors assert that all procedures contributing to this work comply with the ethical standards of the relevant national and institutional committees on human experimentation and with the Helsinki Declaration of 1975, as revised in 2008.

References

- Addington, D., Addington, J., Maticka-Tyndale, E., & Joyce, J. (1992). Reliability and validity of a depression rating scale for schizophrenics. *Schizophrenia Research*, 6, 201–208.
- Allen, T. E., & Agus, B. (1968). Hyperventilation leading to hallucinations. *American Journal of Psychiatry*, 125, 632–637.
- Andreasen, N. C. (1984). *The Scale for the Assessment of Positive Symptoms (SAPS)*. Iowa City, Iowa: The University of Iowa.
- Andrew, E., Gray, N. S., & Snowden, R. J. (2008). The relationship between trauma and beliefs about hearing voices: A study of psychiatric and non-psychiatric voice hearers. *Psychological Medicine*, 38, 1409–1417.
- Badcock, J. C., Paulik, G., & Maybery, M. T. (2011). The role of emotion regulation in auditory hallucinations. *Psychiatry Research*, 185, 303–308.
- Beck, A. T., Epstein, N., Brown, G., & Steer, R. A. (1988). An inventory for measuring clinical anxiety: Psychometric properties. *Journal of Consulting and Clinical Psychology*, 56, 893–897.
- Bell, I. H., Fielding-Smith, S. F., Hayward, M., Rossell, S. L., Lim, M. H., Farhall, J., & Thomas, N. (2018a). Smartphone-based ecological momentary assessment and intervention in a blended coping-focused therapy for distressing voices: Development and case illustration. *Internet Interventions*, 14, 18–25.
- Bell, I. H., Fielding-Smith, S. F., Hayward, M., Rossell, S. L., Lim, M. H., Farhall, J., & Thomas, N. (2018b). Smartphone-based ecological momentary assessment and intervention in a coping-focused intervention for hearing voices (SAVVy): Study protocol for a pilot randomised controlled trial. *Trials*, 19, 262.
- Bell, I. H., Lim, M. H., Rossell, S. L., & Thomas, N. (2017). Ecological momentary assessment and intervention in the treatment of psychotic disorders: A systematic review. *Psychiatric Services*, 68, 1172–1181.
- Benjamin, L. S. (1989). Is chronicity a function of the relationship between the person and the auditory hallucination? *Schizophrenia Bulletin*, 15, 291–310.
- Birchwood, M., & Chadwick, P. (1997). The omnipotence of voices: Testing the validity of a cognitive model. *Psychological Medicine*, 27, 1345–1353.
- Birchwood, M., Macmillan, F., & Smith, J. (1992). Early intervention. In M. Birchwood & N. Tarrier (Eds.), *Innovations in the psychological management of schizophrenia* (pp. 115–145). Chichester: Wiley.
- Broome, M. R., Woolley, J. B., Tabraham, P., Johns, L. C., Bramon, E., Murray, G. K., ... Murray, R. M. (2005). What causes the onset of psychosis? *Schizophrenia Research*, 79, 23–34.
- Carter, D. M., Mackinnon, A., & Copolov, D. L. (1996). Patients' strategies for coping with auditory hallucinations. *The Journal of Nervous and Mental Disease*, 184, 159–164.
- Chadwick, P., & Birchwood, M. (1994). The omnipotence of voices: A cognitive approach to auditory hallucinations. *The British Journal of Psychiatry*, 164, 190–201.
- Chadwick, P., & Birchwood, M. (1995). The omnipotence of voices II: The beliefs about voices questionnaire (BAVQ). *The British Journal of Psychiatry*, 166, 773–776.
- Chadwick, P., Lees, S., & Birchwood, M. (2000). The revised beliefs about voices questionnaire (BAVQ-R). *The British Journal of Psychiatry*, 177, 229–232.
- Chan, Y., So, S. H. W., Mak, A. D. P., Siah, K. T. H., Chan, W., & Wu, J. C. Y. (2019). The temporal relationship of daily life stress, emotions, and bowel symptoms in irritable bowel syndrome – diarrhea subtype: A smartphone-based experience sampling study. *Neurogastroenterology & Motility*, 31, e13514.
- Cheng, S. K. W., Wong, C. W., Wong, K. C., Chong, G. S. C., Wong, M. T. P., Chang, S. S. Y., ... Wu, K. O. (2002). A study of psychometric properties, normative scores, and factor structure of the Beck Anxiety Inventory – the Chinese version. *Chinese Journal of Clinical Psychology*, 10, 4–6.
- Copolov, D. L., Mackinnon, A., & Trauer, T. (2004). Correlates of the affective impact of auditory hallucinations in psychotic disorders. *Schizophrenia Bulletin*, 30, 163–171.
- Cosoff, S. J., & Hafner, R. J. (1998). The prevalence of comorbid anxiety in schizophrenia, schizoaffective disorder and bipolar disorder. *Australian and New Zealand Journal of Psychiatry*, 32, 67–72.
- Csipke, E., & Kinderman, P. (2006). A longitudinal investigation of beliefs about voices. *Behavioural and Cognitive Psychotherapy*, 34, 365–369.
- Curran, P. J., & Bauer, D. J. (2011). The disaggregation of within-person and between-person effects in longitudinal models of change. *Annual Review of Psychology*, 62, 583–619.
- Delespaul, P., Devries, M., & van Os, J. (2002). Determinants of occurrence and recovery from hallucinations in daily life. *Social Psychiatry and Psychiatric Epidemiology*, 37, 97–104.
- Fahrenberg, J., Myrtek, M., Pawlik, K., & Perrez, M. (2007). Ambulatory assessment – monitoring behavior in daily life settings: A behavioral-scientific challenge for psychology. *European Journal of Psychological Assessment*, 23, 206–213.
- Goldstein, H. (1987). *Multilevel models in educational and social research*. London, England: Oxford University Press.
- Hacker, D., Birchwood, M., Tudway, J., Meaden, A., & Amplett, C. (2008). Acting on voices: Omnipotence, sources of threat, and safety-seeking behaviours. *British Journal of Clinical Psychology*, 47, 201–213.
- Haddock, G., McCarron, J., Tarrier, N., & Faragher, E. (1999). Scales to measure dimensions of hallucinations and delusions: The psychotic symptom rating scales (PSYRATS). *Psychological Medicine*, 29, 879–889.
- Hartley, S., Barrowclough, C., & Haddock, G. (2013). Anxiety and depression in psychosis: A systematic review of associations with positive psychotic symptoms. *Acta Psychiatrica Scandinavica*, 128, 327–346.
- Kane, J., Honigfeld, G., Singer, J., & Meltzer, H. (1988). Clozapine for the treatment-resistant schizophrenic: A double-blind comparison with chlorpromazine. *Archives of General Psychiatry*, 45, 789–796.
- Kay, S. R., Fiszbein, A., & Opler, L. A. (1987). The positive and negative syndrome scale (PANSS) for schizophrenia. *Schizophrenia Bulletin*, 13, 261–276.
- Kimhy, D., Delespaul, P., Corcoran, C., Ahn, H., Yale, S., & Malaspina, D. (2006). Computerized experience sampling method (ESMc): Assessing feasibility and validity among individuals with schizophrenia. *Journal of Psychiatric Research*, 40, 221–230.
- Kimhy, D., Wall, M. M., Hansen, M. C., Vakhrusheva, J., Choi, C. J., Delespaul, P., ... Malaspina, D. (2017). Autonomic regulation and auditory hallucinations in individuals with schizophrenia: An experience sampling study. *Schizophrenia Bulletin*, 43, 754–763.
- Larøi, F., Thomas, N., Aleman, A., Fernyhough, C., Wilkinson, S., Deamer, F., & McCarthy-Jones, S. (2019). The ice in voices: Understanding negative content in auditory-verbal hallucinations. *Clinical Psychology Review*, 67, 1–10.
- Leff, J., Tress, K., & Edwards, B. (1988). The clinical course of depressive symptoms in schizophrenia. *Schizophrenia Research*, 1, 25–30.
- Leung, M. H. T., So, S. H. W., Kwok, N. T. K., Ng, I. H. C., Chan, P. S., Lo, C. C. W., ... Lee, S. (2019). Moment-to-moment interaction between affectivity and coping behaviours in bipolar disorder and the role of cognitive appraisals. *BJPsych Open*, 5, e44.
- Lysaker, P. H., & Salyers, M. P. (2007). Anxiety symptoms in schizophrenia spectrum disorders: Associations with social function, positive and negative

- symptoms, hope and trauma history. *Acta Psychiatrica Scandinavica*, 116, 290–298.
- Mawson, A., Cohen, K., & Berry, K. (2010). Reviewing evidence for the cognitive model of auditory hallucinations: The relationship between cognitive voice appraisals and distress during psychosis. *Clinical Psychology Review*, 30, 248–258.
- Meltzer, H. Y. (1992). Treatment of the neuroleptic-nonresponsive schizophrenic patient. *Schizophrenia Bulletin*, 18, 515–542.
- Morrison, A. P., & Renton, J. C. (2001). Cognitive therapy for auditory hallucinations: A theory-based approach. *Cognitive and Behavioral Practice*, 8, 147–160.
- Myin-Germeys, I., Birchwood, M., & Kwapil, T. (2011). From environment to therapy in psychosis: A real-world momentary assessment approach. *Schizophrenia Bulletin*, 37, 244–247.
- Myin-Germeys, I., Delespaul, P., & van Os, J. (2005). Behavioural sensitization to daily life stress in psychosis. *Psychological Medicine*, 35, 733–741.
- Myin-Germeys, I., Kasanova, Z., Vaessen, T., Vachon, H., Kirtley, O., Viechtbauer, W., & Reininghaus, U. (2018). Experience sampling methodology in mental health research: New insights and technical developments. *World Psychiatry*, 17, 123–132.
- Myin-Germeys, I., Nicolson, N., & Delespaul, P. A. (2001). The context of delusional experiences in the daily life of patients with schizophrenia. *Psychological Medicine*, 31, 489–498.
- Myin-Germeys, I., Oorschot, M., Collip, D., Lataster, J., Delespaul, P., & van Os, J. (2009). Experience sampling research in psychopathology: Opening the black box of daily life. *Psychological Medicine*, 39, 1533–1547.
- Nayani, T. H., & David, A. S. (1996). The auditory hallucination: A phenomenological survey. *Psychological Medicine*, 26, 177–189.
- Oorschot, M., Lataster, T., Thewissen, V., Bentall, R., Delespaul, P., & Myin-Germeys, I. (2012). Temporal dynamics of visual and auditory hallucinations in psychosis. *Schizophrenia Research*, 140, 77–82.
- Peters, E., Lataster, T., Greenwood, K., Kuipers, E., Scott, J., Williams, S., ... Myin-Germeys, I. (2012a). Appraisals, psychotic symptoms and affect in daily life. *Psychological Medicine*, 42, 1013–1023.
- Peters, E. R., Williams, S. L., Cooke, M. A., & Kuipers, E. (2012b). It's not what you hear, it's the way you think about it: Appraisals as determinants of affect and behaviour in voice hearers. *Psychological Medicine*, 42, 1507–1514.
- Scollon, C. N., Prieto, C. K., & Diener, E. (2009). Experience sampling: Promises and pitfalls, strength and weaknesses. In E. Diener (Ed.), *Assessing well-being* (pp. 157–180). Dordrecht: Springer.
- Shiffman, S., Stone, A. A., & Hufford, M. R. (2008). Ecological momentary assessment. *Annual Review of Clinical Psychology*, 4, 1–32.
- Simons, C. J. P., Drukker, M., Evers, S., van Mastrigt, G. A. P. G., Höhn, P., Kramer, I., ... Wichers, M. (2017). Economic evaluation of an experience sampling method intervention in depression compared with treatment as usual using data from a randomized controlled trial. *BMC Psychiatry*, 17, 415.
- Slade, P. (1976). An investigation of psychological factors involved in the predisposition to auditory hallucinations. *Psychological Medicine*, 6, 123–132.
- Smith, B., Fowler, D. G., Freeman, D., Bebbington, P., Bashforth, H., Garety, P., ... Kuipers, E. (2006). Emotion and psychosis: Links between depression, self-esteem, negative schematic beliefs and delusions and hallucinations. *Schizophrenia Research*, 86, 181–188.
- So, E., Kam, I., Leung, C., Chung, D., Liu, Z., & Fong, S. (2003). The Chinese-bilingual SCID-I/P Project: Stage 1 – reliability for mood disorders and schizophrenia. *Hong Kong Journal of Psychiatry*, 13, 7–19.
- So, S. H., & Wong, C. (2008). Experience and coping with auditory hallucinations in first-episode psychosis: Relationship with stress coping. *East Asian Archives of Psychiatry*, 18, 115–121.
- So, S. H. W., Peters, E. R., Swendsen, J., Garety, P. A., & Kapur, S. (2013). Detecting improvements in acute psychotic symptoms using experience sampling methodology. *Psychiatry Research*, 210, 82–88.
- So, S. H. W., Peters, E. R., Swendsen, J., Garety, P. A., & Kapur, S. (2014). Changes in delusions in the early phase of antipsychotic treatment – an experience sampling study. *Psychiatry Research*, 215, 568–573.
- Soppitt, R. W., & Birchwood, M. (1997). Depression, beliefs, voice content and topography: A cross-sectional study of schizophrenic patients with auditory verbal hallucinations. *Journal of Mental Health*, 6, 525–532.
- Tarrier, N., Beckett, R., Harwood, S., Baker, A., Yusupoff, L., & Ugarteburu, I. (1993). A trial of two cognitive-behavioural methods of treating drug-resistant residual psychotic symptoms in schizophrenic patients: I. Outcome. *British Journal of Psychiatry*, 162, 524–532.
- Thomas, N., Hayward, M., Peters, E., van der Gaag, M., Bentall, R. P., Jenner, J., ... McCarthy-Jones, S. (2014). Psychological therapies for auditory hallucinations (voices): Current status and key directions for future research. *Schizophrenia Bulletin*, 40, S202–S212.
- Turnbull, G., & Bebbington, P. (2001). Anxiety and the schizophrenic process: Clinical and epidemiological evidence. *Social Psychiatry and Psychiatric Epidemiology*, 36, 235–243.
- Udachina, A., Bentall, R. P., Varese, F., & Rowse, G. (2017). Stress sensitivity in paranoia: Poor-me paranoia protects against the unpleasant effects of social stress. *Psychological Medicine*, 47, 2834–2843.
- Vaessen, T., Kasanova, Z., Hernaes, D., Lataster, J., Collip, D., van Nierop, M., & Myin-Germeys, I. (2018). Overall cortisol, diurnal slope, and stress reactivity in psychosis: An experience sampling approach. *Psychoneuroendocrinology*, 96, 61–68.
- van der Gaag, M., Hageman, M. C., & Birchwood, M. (2003). Evidence for a cognitive model of auditory hallucinations. *The Journal of Nervous and Mental Disease*, 191, 542–545.
- van der Gaag, M., Valmaggia, L. R., & Smit, F. (2014). The effects of individually tailored formulation-based cognitive behavioural therapy in auditory hallucinations and delusions: A meta-analysis. *Schizophrenia Research*, 156, 30–37.
- van Os, J., Verhagen, S., Marsman, A., Peeters, F., Bak, M., Marcelis, M., ... Delespaul, P. (2017). The experience sampling method as an mHealth tool to support self-monitoring, self-insight, and personalized health care in clinical practice. *Depression and Anxiety*, 34, 481–493.
- Varese, F., Udachina, A., Myin-Germeys, I., Oorschot, M., & Bentall, R. P. (2011). The relationship between dissociation and auditory verbal hallucinations in the flow of daily life of patients with psychosis. *Psychosis*, 3, 14–28.
- Wang, L. P., & Maxwell, S. E. (2015). On disaggregating between-person and within-person effects with longitudinal data using multilevel models. *Psychological Methods*, 20, 63–83.
- Waters, F., & Fernyhough, C. (2017). Hallucinations: A systematic review of points of similarity and difference across diagnostic classes. *Schizophrenia Bulletin*, 43, 32–43.
- Westermann, S., Grezellschak, S., Oravec, Z., Moritz, S., Lüdtke, T., & Jansen, A. (2017). Untangling the complex relationships between symptoms of schizophrenia and emotion dynamics in daily life: Findings from an experience sampling pilot study. *Psychiatry Research*, 257, 514–518.
- Wong, A. W., & Chen, E. Y. (2015). Psychometric properties of translated outcome measures of cognitive behavioural therapy for psychosis in the Chinese context. *Asian Journal of Psychiatry*, 13, 62–65.
- Yung, A. R., & McGorry, P. D. (1996). The prodromal phase of first-episode psychosis: Past and current conceptualizations. *Schizophrenia Bulletin*, 22, 353–370.