

REVIEW ARTICLE

Sign-Based Construction Grammar: A guided tour¹

FRANK VAN EYNDE

University of Leuven

(Received 10 March 2015; revised 25 August 2015)

Hans C. Boas & Ivan A. Sag (eds.), *Sign-Based Construction Grammar*.
Stanford: CSLI Publications, 2012. Pp. xvi + 391.

Sign-Based Construction Grammar (SBCG) is, on the one hand, a formalized version of Berkeley Construction Grammar (BCG), and, on the other hand, a further development of constructionist Head-driven Phrase Structure Grammar (HPSG). The volume edited by Hans Boas and Ivan Sag is the first book length presentation of the framework. Its centerpiece is a 130-page synopsis of the theory by Ivan Sag. The other contributions to the volume provide background, justification, case studies, an extension to diachronic syntax and a presentation of the FrameNet Constructicon. This review gives a guided tour of the framework, explaining its central notions and assumptions, as well as the notation in which they are cast. It also compares the SBCG framework with other types of Construction Grammar and with HPSG. The case studies are summarized and briefly evaluated.

1. WHAT'S IN A NAME?

Construction Grammar (CxG) is a label that stands for a family of frameworks that stress the importance of constructions in linguistic theory. The original members of the family are known as Cognitive Construction Grammar² and Berkeley Construction Grammar.³ A common characteristic is the tendency to focus on irregularities and idiosyncratic phenomena, in reaction to frameworks that prefer to treat these as marginal or irrelevant, such as Transformational Grammar with its distinction between core and periphery. Besides, the approach

[1] This paper has benefited greatly from the comments that I received from the editor and two anonymous *J. Linguistics* referees, as well as from Stefan Müller. Very useful were also the reactions of the audience of a course on SBCG which I gave for the LOT Summer School in 2015.

I wish to dedicate this article to the memory of Ivan Andrew Sag (1949–2013), a brilliant linguist and a good friend.

[2] Lakoff (1987), Langacker (1987), Goldberg (1995, 2006).

[3] Fillmore, Kay & O'Connor (1988), Fillmore & Kay (unpublished), Kay & Fillmore (1999).

is inductive rather than deductive, and there is a certain reluctance, especially in Cognitive Construction Grammar, to make use of formal notation. Over time the family has expanded. New members include Radical Construction Grammar with its emphasis on typology and comparative studies (Croft 2001), Embedded Construction Grammar with its emphasis on human language processing (Bergen & Chang 2009) and Fluid Construction Grammar with its emphasis on computational language processing (Steels 2011). Given its name, Sign-Based Construction Grammar (SBCG) could be seen as the newest member of this expanding family, but this impression is misguided, for two reasons.

The first reason is that it is not so much a new branch of Construction Grammar as a continuation of Berkeley Construction Grammar (BCG). In fact, SBCG aims to be ‘recognizable as a formalized version of BCG, with a few straightforward (and only minimal) notational adjustments’ (Sag 2012: 70). The second reason is that SBCG is to a large extent a continuation of Head-driven Phrase Structure Grammar (HPSG), a lexicalist constraint-based framework that took shape around the same time as BCG in the mid eighties, and that aimed to provide a monostratal surface-oriented alternative for the then prevailing Transformational Grammar framework.⁴ In that respect it joined arms and tools with a number of other frameworks, including Generalized Phrase Structure Grammar,⁵ Lexical-Functional Grammar⁶ and Categorical Grammar. The emphasis on matters of formalization in these frameworks was not likely to endear them in CxG circles, but there was nonetheless a rapprochement between HPSG and BCG in the mid nineties. This was largely the consequence of the growing realization in HPSG that the properties of composed signs cannot always be derived from the properties of lexical elements and a few very general combination schemata. Ivan Sag’s work on relative clauses (Sag 1997) was a first step toward the inclusion of more specific combination schemata, and Ginzburg & Sag (2000) consolidated it, yielding what is now known as constructionist HPSG. It is this branch of HPSG that is in fact the main source of inspiration for Sign-Based Construction Grammar.

Boas & Sag (2012) is the first comprehensive presentation of SBCG. It consists of seven contributions by various authors. The centerpiece is a near book length synopsis of the framework by Ivan Sag. The other contributions provide background (Ivan Sag, Hans Boas & Paul Kay), justification (Laura Michaelis), case studies (Gert Webelhuth and Paul Kay & Ivan Sag), an extension to diachronic syntax (Jóhanna Barddal & Þórhallur Eythórsson) and a presentation of the FrameNet Constructicon (Charles Fillmore, Russell Lee-Goldman & Russell Rhomieux). This review focuses on the centerpiece in Section 2 and on the case studies in Section 3. The other contributions are discussed in Sections 4 and 5. Unless indicated otherwise, all quotes are from Boas & Sag (2012).

[4] Pollard & Sag (1987), Pollard & Sag (1994).

[5] Gazdar, Klein, Pullum & Sag (1985).

[6] Bresnan (1982), Bresnan (2000).

2. THE SBCG FRAMEWORK

A presentation of the leading ideas of SBCG inevitably involves the use of formal notation. Its importance is in fact stressed throughout the volume, starting in the introduction: ‘With formalization comes more precise empirical prediction, enhanced comparability of analyses across languages, and general theoretical clarity.’ (p. 3). For this reason we start the guided tour with a look at the central notions of the framework, paying special attention to the way in which they are captured in formal notation. These central notions include signs (Section 2.1), constructs (Section 2.2) and constructions (Section 2.3). The last subsection (Section 2.4) provides a comparison with CXG and constructionist HPSG.

2.1 *Signs*

As in HPSG, the central notion in SBCG is that of the linguistic sign. In terms of the typed feature structure notation that has become the *lingua franca* for a wide spectrum of computational and formal linguists, signs are declared to have the following features (p. 98).⁷

- (1) *sign* :

PHONOLOGY	<i>phonological-object</i>
FORM	<i>morphological-object</i>
SYNTAX	<i>syntax-object</i>
SEMANTICS	<i>semantic-object</i>
CONTEXT	<i>context-object</i>

The values of the PHONOLOGY and FORM features represent respectively the spoken and the written forms of signs, the value of the SYNTAX feature contains information about category and valence, and the values of the SEMANTICS and CONTEXT features jointly represent the meanings of signs. As an example, the past tense form of the English *laugh* has the PHONOLOGY value */læf-d/*, the FORM value *<laughed>*, a SYNTAX value that contains the information that it is an intransitive finite verb, a SEMANTICS value that contains the information that it denotes a situation in which somebody laughs and a CONTEXT value that contains the time of utterance with respect to which the tense of the verb is understood.

This definition of the sign is deliberately reminiscent of Saussure’s conception of the sign as a unit of form (*signifiant*) and meaning (*signifié*) (de Saussure 1916). It gives substance to the claim ‘that construction-based grammar has deep roots in Structural Linguistics’ (p. 70). While the Saussurean sign is first and foremost a lexical sign, the signs of HPSG/SBCG also include phrases, sentences and other larger units. In fact they come in a variety of types which are organized in a hierarchy (p. 98).

[7] (1) is a type declaration. It is of the form $\tau:D$, where the features in the description D are declared to be appropriate for entities of type τ .

(2)

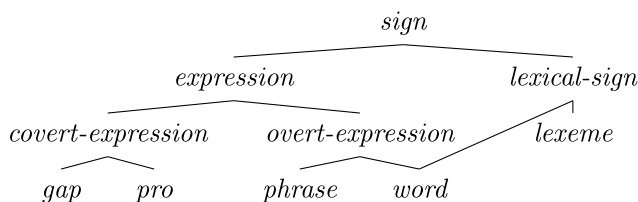

Overt expressions are the words and phrases that show up in sentences. Covert expressions include unbounded dependency gaps and silent pronouns. Lexemes stand for classes of words that belong to the same inflectional paradigm, such as *laugh*, *laughs*, *laughed* and *laughing*. They are comparable to lemmata in monolingual dictionaries. The reason why they do not belong to the overt expressions is that they do not show up in sentences: sentences are not made up of lexemes, but of the words that are derived from lexemes, see [Section 2.3](#).

Subtypes inherit the properties of their supertypes.⁸ This implies that the various types of signs have (at least) the features that are mentioned in (1). Besides, they may have features of their own. Words and lexemes, for instance, have an ARG(UMENT)-ST(RUCTURE) feature whose value ‘encodes the combinatoric potential of a lexical sign by listing its potential syntactico-semantic arguments’ (p. 79).

(3) *lexical-sign* : $\left[\text{ARG-ST } \textit{list}(\textit{expression}) \right]$

The ARG-ST value of the verb *read*, for instance, is a list that contains two noun phrases. Notice that the elements on the list are required to be expressions. Given the type hierarchy in (2), this implies that they may be phrases, words or covert expressions, but not lexemes. The list may also be empty, as in the case of proper nouns and pronouns, which do not select any arguments.

To spell out the syntactic properties of signs, the values of the SYNTAX feature are given further structure, as in (4).

(4) *syntax-object* : $\left[\begin{array}{ll} \text{CATEGORY} & \textit{category} \\ \text{VALENCE} & \textit{list}(\textit{expression}) \\ \text{MARKING} & \textit{marking} \end{array} \right]$

The CATEGORY value is a part of speech, such as noun or verb. It may in turn be declared to have category-specific features, such as VFORM for verbs and CASE for (pro)nouns.

(5) *noun* : $\left[\text{CASE } \textit{case} \right]$ *verb* : $\left[\text{VFORM } \textit{vform} \right]$

[8] A subtype may inherit from more than one supertype. Words, for instance, inherit the properties of both the lexical signs and the overt expressions. This is called multiple inheritance.

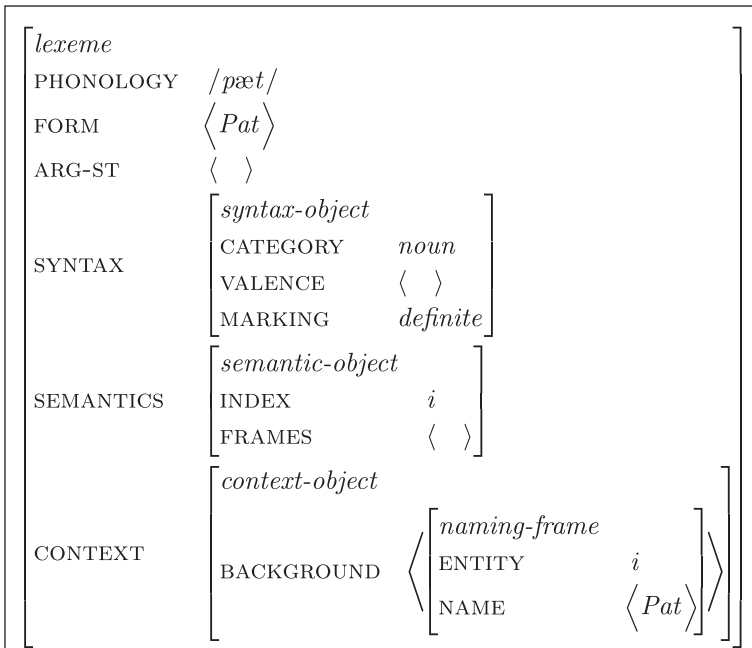

Figure 1
A model of the lexeme *Pat*.

The VALENCE value is a list of expressions, just like ARG-ST. In contrast to the latter, it figures in the representations of all signs, not just the lexical ones. Its function is to keep track of which of the arguments are realized locally. The MARKING value contains the information that is provided by specifiers and modifiers. In a similar way, the values of the SEMANTICS and CONTEXT features are given structure to spell out the semantic properties of signs. This is largely done in terms of frames, a central notion of Berkeley Construction Grammar.

Employing the types and their features, one can model the information that is conveyed by particular signs, as in Figure 1, which represents some of the properties of the lexeme *Pat*.⁹ Figure 1 is a typed feature structure. It provides information about the form of the sign, in both phonological and orthographic terms, it specifies that *Pat* does not select any arguments, that it is a fully saturated definite noun and that it denotes an entity *i* that bears the name *Pat*. Typed feature structures model the properties of individual signs. They are surrounded by boxes in order to differentiate them from the properties that apply to classes of signs. The latter are called descriptions.

[9] *< >* stands for the empty list. Lexemes with an empty FRAMES list lack descriptive content.

2.2 *Constructs*

Constructs are local trees, consisting of a mother and at least one daughter (p. 106).¹⁰

$$(6) \text{ construct} : \left[\begin{array}{ll} \text{MOTHER} & \textit{sign} \\ \text{DAUGHTERS} & \textit{nelist}(\textit{sign}) \end{array} \right]$$

Just like the signs, the constructs are organized in a hierarchy. The basic distinction is that between lexical and phrasal constructs (p. 107).

$$(7) \begin{array}{c} \textit{construct} \\ \hline \textit{lexical-cxt} \quad \textit{phrasal-cxt} \end{array}$$

Lexical constructs model the results of morphological processes, such as inflection, derivation and compounding. Their DAUGHTERS value is a list of lexical signs, i.e. words or lexemes. Phrasal constructs model the results of phrase formation. Their MOTHER value is a phrase, and their DAUGHTERS value is a list of overt expressions, i.e. words or phrases.

$$(8) \textit{lexical-cxt} : \left[\begin{array}{ll} \text{DAUGHTERS} & \textit{list}(\textit{lexical-sign}) \end{array} \right]$$

$$(9) \textit{phrasal-cxt} : \left[\begin{array}{ll} \text{MOTHER} & \textit{phrase} \\ \text{DAUGHTERS} & \textit{list}(\textit{overt-expression}) \end{array} \right]$$

Notice that the type declarations in (8) and (9) are more specific versions of the type declaration in (6).

At a finer-grained level the hierarchy distinguishes a number of more specific lexical and phrasal constructs. The most important of the former are the inflectional and derivational ones.

$$(10) \begin{array}{c} \textit{lexical-cxt} \\ \hline \textit{inflectional-cxt} \quad \textit{derivational-cxt} \quad \dots \end{array}$$

The mother of an inflectional construct is a word and its daughter is a list of lexemes.

$$(11) \textit{inflectional-cxt} : \left[\begin{array}{ll} \text{MOTHER} & \textit{word} \\ \text{DAUGHTERS} & \textit{list}(\textit{lexeme}) \end{array} \right]$$

The construct that represents the word *laughs*, for instance, is a tree with the inflected form as the mother and the lexeme as its only daughter. Notice that the

[10] *nelist* is short for non-empty list, i.e. a list with at least one member.

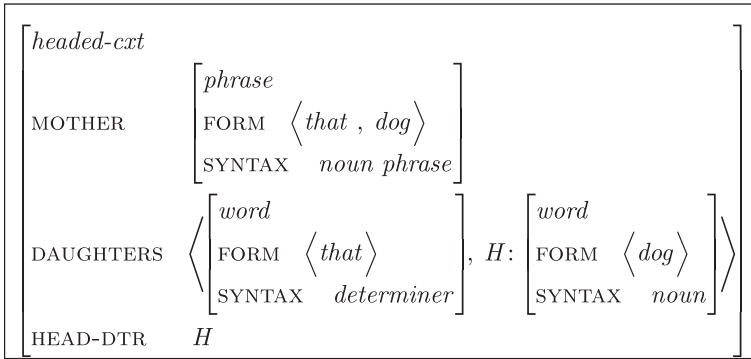

Figure 2
A partial representation of the phrasal construct *that dog*.

mother and the daughter are not just forms, but fully fledged signs, including the values of syntactic and semantic features.

The mother of a derivational construct is a lexeme. The representation of *unable*, for instance, is a tree with the derived lexeme as the mother and the lexeme *able* as its only daughter.

$$(12) \textit{derivational-cxt} : \left[\textit{MOTHER} \textit{ lexeme} \right]$$

Since compounding is also treated as derivational, there can be more than one daughter, as in *rain coat*. Since the daughters can be inflected words, as in *women friends* and *Beatles fan*, they are not required to be lexemes.

The basic distinction in the hierarchy of phrasal constructs is that between headed and non-headed constructs.

$$(13) \begin{array}{c} \textit{phrasal-cxt} \\ \underbrace{\hspace{10em}} \\ \textit{headed-cxt} \quad \textit{nonheaded-cxt} \end{array}$$

The headed constructs have an extra feature that identifies the head daughter.

$$(14) \textit{headed-cxt} : \left[\textit{HEAD-DAUGHTER} \textit{ overt-expression} \right]$$

The non-headed constructs, such as the coordinate ones, lack this feature. Since head daughters are required to be overt expressions, they cannot be gaps or silent pronouns.

Constructs are of the same level of specificity as signs. To make this explicit they are surrounded by boxes, as in Figure 2. This is a partial representation, because it only contains the FORM and SYNTAX features. *H* is both the second member of DAUGHTERS and the value of HEAD-DTR. It is comparable to a variable in logic.

2.3 Constructions

It is not in terms of the individual signs and constructs that linguistic generalizations are expressed, but rather in terms of constructions. These apply to classes of signs and constructs. Technically, they are implicational constraints of the form $\tau \Rightarrow D$, where τ is a type and D a description. There are two kinds of constructions in SBCG: lexical class constructions (Section 2.3.1) and combinatoric constructions (Section 2.3.2).

2.3.1 Lexical class constructions

Taking a second look at the typed feature structure of *Pat* in Figure 1, it is clear that it contains a lot of information that is shared with other proper nouns. To capture this, the hierarchy of lexeme types is extended as in (15).

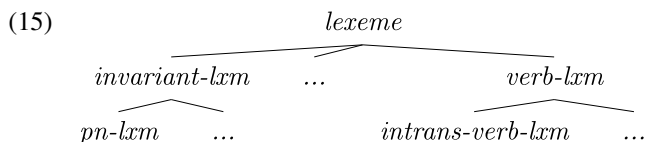

The invariant lexemes are those that do not show any inflectional variation. In English they comprise among others the proper noun lexemes (*pn-lxm*).¹¹ The properties that the proper noun lexemes have in common are spelled out in (16) (p. 109).

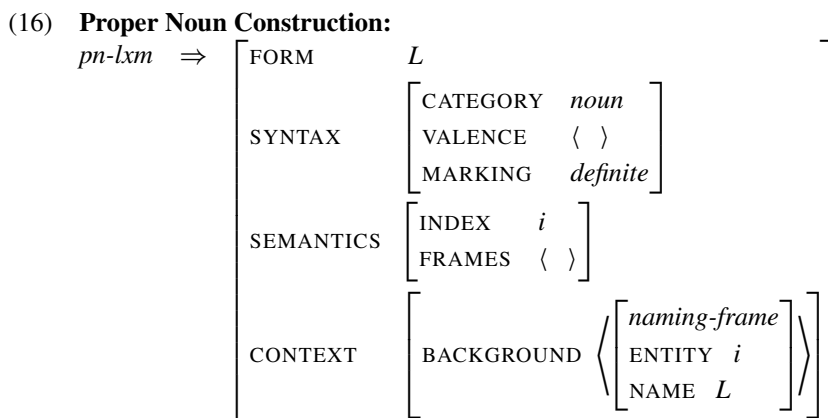

In (16) the fact is captured that proper noun lexemes are nouns, that they do not select any valents (subjects or complements), that they are syntactically definite, that they denote an entity, that they lack descriptive content and that the denoted

[11] The combination of a proper noun with the possessive 's, as in *Pat's bike*, is not treated as an instance of word formation, but as an instance of phrase formation, involving a nominal and a clitic pronoun, see Pollard & Sag (1994: 53–54).

individual has a name L which is identified with the FORM value of the proper noun. Here, L stands for a list, since proper nouns may consist of more than one word, as in *New York* and *Vladimir Putin*.

Given the constraint in (16), the lexical entry of *Pat* can be reduced to the assignment of the relevant type and the information that is specific for it, such as the fact that its FORM value is $\langle Pat \rangle$. Lexical entries that have been reduced to the information that is specific for them are called listemes. This term ‘is first proposed by di Sciullo & Williams (1987) as a generalization of the notion “lexical entry” to include multiword expressions of various kinds’ (p. 71). The set of all listemes of some given language is its lexicon.

2.3.2 Combinatoric constructions

Regularities in word and phrase formation are modeled in terms of combinatoric constructions. Technically, they are implicational constraints that apply to types of constructs. As an example let us take the construction that licenses inflectional constructs in (17) (p. 185).

(17) **Inflectional Construction:**

$$inflectional-cxt \Rightarrow \left[\begin{array}{l} \text{MOTHER} \quad \left[\begin{array}{ll} \text{ARG-ST} & L \\ \text{CONTEXT} & X \end{array} \right] \\ \text{DAUGHTERS} \quad \left\langle \left[\begin{array}{ll} \text{ARG-ST} & L \\ \text{CONTEXT} & X \end{array} \right] \right\rangle \end{array} \right]$$

This constraint states that the ARGUMENT-STRUCTURE and CONTEXT values of a word have to be identical to those of the lexeme from which the word is derived. It also adds the constraint that there is one and only one daughter. Notice the difference between the type declaration in (11) and the construction in (17). The former spells out what the relevant features for the inflectional constructs are and what their possible values are, while the latter puts constraints on the values of those features and especially on the identity relations between those values.

More specific inflectional processes are spelled out in terms of constraints on subtypes of the inflectional constructs. Of special relevance for English is the one that models zero inflection, i.e. the derivation of a word from a lexeme that does not involve any addition of affixes (p. 119).

(18) **Zero Inflection Construction:**

$$zero-infl-cxt \Rightarrow \left[\begin{array}{ll} \text{MOTHER} & X! \textit{word} \\ \text{DAUGHTERS} & \langle X : \textit{invariant-lxm} \rangle \end{array} \right]$$

The constructs that are licensed by this construction have a daughter of type *invariant-lexeme*. In English, they comprise among others the proper nouns, the adjectives, the adverbs and the prepositions. The mother shares all of its properties

(X) with its daughter, except for those that are spelled out after the exclamation mark (!). In this case that is just the type of the mother, i.e. *word*.

There are similar constructions for licensing phrasal constructs. To illustrate how they work I start from the hierarchy of headed constructs in (19).

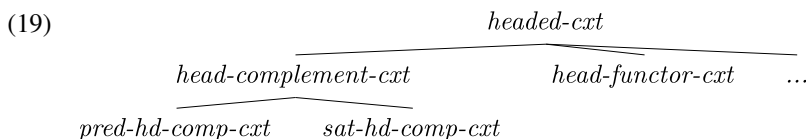

The head-complement constructs are local trees consisting of a mother, a head daughter and at least one other daughter. They are partitioned into those that are fully saturated (*saturational-head-comp-cxt*) and those that still need an external argument (*predicational-head-comp-cxt*). The construction that licenses the latter is given in (20) (p. 152).¹²

(20) **Predicational Head-Complement Construction:**

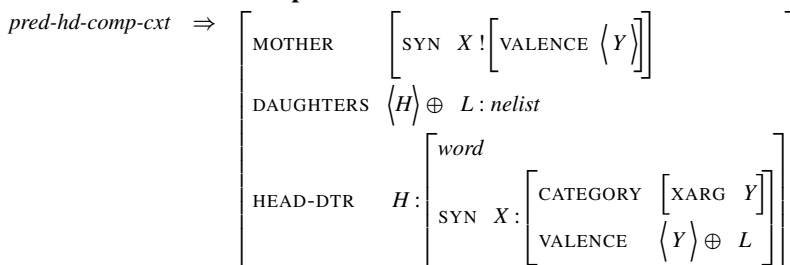

The construction in (20) licenses constructs that contain a mother and a list of daughters of which the first one (*H*) is the head daughter. The head daughter is required to be a word that selects an external argument (*Y*) and a non-empty list of complements (*L*). The requirements on those complements are matched with the list of non-head daughters, and the mother has the same SYN(TAX) value as the head daughter (*X*) except for (!) the fact that the complement requirements are subtracted from the VALENCE list. A finite verb phrase, such as *met his uncle*, for instance, is verbal and finite, just like its head daughter *met*, but in contrast to the latter it no longer requires a direct object.

The construction in (20) is extremely general: it not only licenses the combination of a verb with its complement(s), but also of a preposition with its complement, as in *under the table*, of an adjective with its complement, as in *proud of his bike*, and of a noun with its complement, as in *destruction of Rome*. This high level of generality is made explicit by the high position of the *pred-hd-comp-cxt* type in the hierarchy of phrasal constructs.

The tendency toward generalization is also clear from the introduction of the head-functor constructs, first proposed in Van Eynde (1998, 2006) and

[12] \oplus is the concatenation operation on lists.

Allegrezza (1998, 2007). This type models the combination of a head with its modifiers, specifiers and markers. The construction that licenses them is spelled out in (21).

(21) **Head-Functor Construction:**

$$head\text{-}func\text{-}cxt \Rightarrow \left[\begin{array}{l} \text{MOTHER} \quad \left[\text{SYN } X \! \left[\text{MARKING } M \right] \right] \\ \text{DAUGHTERS} \quad \left\langle \left[\text{SYN} \left[\text{CAT} \left[\text{SELECT } H \right] \right] \right] \right\rangle, H : \left[\text{SYN } X \right] \right\rangle \\ \text{HEAD-DTR} \quad H \end{array} \right]$$

A head-functor construct consists of a mother and two daughters, of which the second one is the head daughter (*H*). The first daughter (the functor) selects the head daughter, and the mother shares its SYN(TAX) value (*X*) with the head daughter except for (!) the MARKING value (*M*), which it shares with the functor daughter.¹³ Some examples of this type of construct are the combination of an attributive adjective and a noun, as in *red box*, and of a determiner with a nominal, as in *every box*. In such combinations, the non-head daughter (the functor) selects its head sister. The attributive *red*, for instance, selects a bare nominal, the quantifying *every* selects a singular count bare nominal, the demonstrative *those* a plural bare nominal, and so on.¹⁴ The MARKING feature is used among others to differentiate the functors that can be stacked, as in *big red box*, from those that cannot, as in *every that box*. To model this, attributive adjectives are required to select a bare nominal and are marked as bare themselves, so that the resulting combination is compatible with another attributive adjective. A demonstrative determiner, by contrast, selects a bare nominal, but its own MARKING value is not bare, which implies that the resulting combination is not bare either, and is hence incompatible with an attributive adjective or another determiner.

The totality of combinatoric constructions that jointly describe a given language is called its construction. Together with the lexicon, it constitutes the full description of the language.

While the constructions that have been presented in this section are characterized by a high level of generality, it is also possible and in fact essential for the SBCG enterprise to add and define constructions with a lower level of generality. A good example is the construction that models the idiosyncratic properties of the verb phrases in (22).

- (22) (a) Chris lied his way into the meeting.
- (b) She whistled her way out of the room.

[13] The MARKING feature was introduced in Pollard & Sag (1994: 44–46) to model the combination of a complementizer and a clause, but it has a much broader range of application in the functor analysis.

[14] The feature that models this selection (SELECT) replaces the MOD(IFIED) and SPEC(IFIED) features of earlier HPSG. Moreover, it makes the SPR feature for the selection of a specifier by its head superfluous.

The construction that models this is a constraint on lexical constructs that extends the ARG-ST of the verb with an NP that is headed by *way* and a directional PP (p. 142).

In a similar way, one can define constraints on phrasal constructs in order to model patterns of phrase formation with a low level of generality. Examples will be given in [Section 3](#).

Since the constructs are all part of the same hierarchy, no matter how general or specific they are, this method of description provides a natural way to integrate the general and the idiosyncratic. This fits in well with – in fact it formalizes – one of the central tenets of Berkeley Construction Grammar:

To know what is idiomatic about a phrase one has to know what is nongeneral and to identify something as nongeneral one has to be able to identify the general ... The picture that emerges from the consideration of special constructions is of a grammar in which the particular and the general are knit together seamlessly. (Kay & Fillmore 1999)

2.3.3 *Summing up*

The relation between signs, constructs, listemes and constructions is spelled out in the Sign Principle (p. 105).

(23) **The Sign Principle:**

Every sign must be listemically or constructionally licensed, where:

- a sign is listemically licensed only if it satisfies some listeme, and
- a sign is constructionally licensed only if it is the mother of some well-formed construct.

In combination with some given lexicon, a constructicon and a type hierarchy, this principle differentiates the well-formed signs from the ill-formed ones.

2.4 *A comparison with CxG and constructionist HPSG*

The SBCG treatment of constructions bears obvious similarities to both the BCG treatment and the constructionist HPSG treatment, but there are also some differences. A major difference from BCG concerns the insistence on locality:

(24) **Constructional Localism:**

Constructions license mother–daughter configurations without reference to embedding or embedded contexts.

This contrasts with BCG-style constructions, which allow configurations of arbitrary depth. The localism requirement implies that non-local phenomena, such as unbounded dependencies, require the use of structure sharing, along the same lines as in HPSG. Another difference from BCG, and in fact from Construction Grammar in general, is that the inheritance of properties is constrained by the type

hierarchy. This is not the case in CxG, where ‘constructions are combined (unified) freely to form actual expressions as long as they don’t conflict’ (Goldberg 2009: 97). For both differences, the book provides ample motivation, not only in Ivan Sag’s contribution, but also in the contribution by Laura Michaelis and in the introductory chapter by Ivan Sag, Hans Boas and Paul Kay.

A property that SBCG shares with BCG but not with the other branches of Construction Grammar is the possibility for constructions to exclusively constrain form or meaning. This is not possible in Cognitive Construction Grammar, since it defines a construction as ‘any conventionalized pairing of form and meaning’. An example of a construction that does not fit this mould is Subject–Auxiliary Inversion (SAI). While syntactically uniform, it is semantically heterogeneous, comprising polar questions, exclamatives, inverted wishes, irrealis conditions, and the like (p. 77). To model this it makes sense to have an SAI supertype that exclusively refers to syntactic properties and a number of subtypes that add more specific semantic constraints.

A major difference from constructionist HPSG concerns the addition of a hierarchy of constructs to the grammar:

To readers steeped in HPSG theory, SBCG will no doubt seem like a minor variant of constructional HPSG (as developed in Sag (1997), Ginzburg & Sag (2000) and elsewhere), with the principal innovation being the introduction of the distinction between signs and constructs. (p. 70)

A motivation for this change is not given explicitly, but it is safe to guess that it relates to the locality issue. While HPSG signs can be of arbitrary depth, containing daughters that in turn have other daughters, constructs are local trees and, hence, of depth 1. In practice, this difference is not that large, since it has always been a matter of good practice in HPSG to define constraints and phrase structure schemata in a localist manner. In SBCG this limitation is wired into the framework itself. The cost is the addition of an extra feature, i.e. MOTHER. This move is criticized in Müller (2015: 297):

... this new organization of features does not bring with it any advantages. Since the grammar becomes more complex (an additional feature, meta-restriction), we should reject this change... if we do reject the revised feature geometry, then Sign-Based Construction Grammar and Constructionist HPSG are (almost) indistinguishable.¹⁵

As a long-time fan of Occam’s razor, I have some sympathy for this objection, but hasten to add that the addition of the MOTHER feature is compensated by the elimination of HPSG’s LOCAL feature.

Another difference from HPSG concerns the values of the selection features, such as ARG-ST, VALENCE and SELECT. In HPSG these are lists of SYNSEM values, but in SBCG they are full signs.¹⁶ This implies that selection features

[15] The intended meta-restriction is the Sign Principle.

[16] This change paves the way for the elimination of HPSG’s SYNSEM feature.

cannot only impose constraints on the syntactic and semantic properties of the selected elements, but also on their phonological, morphological and contextual properties. This is a non-trivial extension, but it is introduced without explanation or motivation. A possible motivation, suggested by an anonymous reviewer, is the treatment of such phenomena as the allomorphy of the English indefinite article (*a* versus *an*), whose complementary distribution can be modeled in terms of the SELECT feature, if that feature has access to the phonological properties of (the first phone of) the selected nominal.

In sum, while the differences with respect to BCG are spelled out and motivated in detail, the differences from constructionist HPSG receive far less attention. This is not entirely surprising given that the goal of SBCG is ‘to expand the empirical coverage of HPSG, while at the same time putting BCG on a firmer theoretical footing’ (p. 70). In other words, while BCG is shaken into another somewhat more solid form, HPSG is just stirred and expanded. The novelty with respect to HPSG is, hence, to be found in the treatment of a number of phenomena that had received little or no attention before. They include locative alternations, extended valence constructions, as in *Pat sneezed the napkin off the table*, and a treatment of the *What’s X doing Y* combination. Another novelty is a sketchy but intriguing treatment of the English auxiliaries, in which the Boolean AUX distinction is not applied to lexical elements, but to constructions.

3. TWO CASE STUDIES

The case studies show how the SBCG framework can be used for the description of specific phenomena. For ease of reference, the titles of the subsections are identical to the titles of the respective papers.

3.1 *Cleaning up the big mess: Discontinuous dependencies and complex determiners*

This contribution by Paul Kay and Ivan Sag (pp. 229–256) is a showcase of how SBCG deals with phenomena that show a subtle interaction of the general and the specific. The relevant phenomena are discontinuous dependencies, as in (25), and complex predeterminers, as in (26).

- (25) (a) [**so** willing to help out] that they called early
 (b) [**more** ready for what was coming] than I was
- (26) (a) [[**that** friendly] a policeman]
 (b) [[**how** hard] a problem] was it?

The clausal complements of the bold faced degree markers in (25) are not realized within the bracketed AP, but extraposed, and the APs with the bold faced degree markers in (26) are not realized in the canonical position for attributive APs, i.e. in between the determiner and the noun, but in the predeterminer position. The two phenomena may co-occur as in (27).

- (27) (a) [[[so big] a mess] resulted from the meeting of the committee on the seventeenth of August] that it took hours to clean it up
 (b) [[more sincere] an apology] than her critics acknowledged

To model the **discontinuous dependencies** Kay & Sag (2012) employ the feature EXTRA, briefly mentioned in a footnote in Pollard & Sag (1994: 366) and adopted for a monostratal treatment of extraposition in, among others, Bouma (1996), Van Eynde (1996) and Kim & Sag (2005). It is integrated in the listemes of the degree markers, such as the one for *so* in (28).

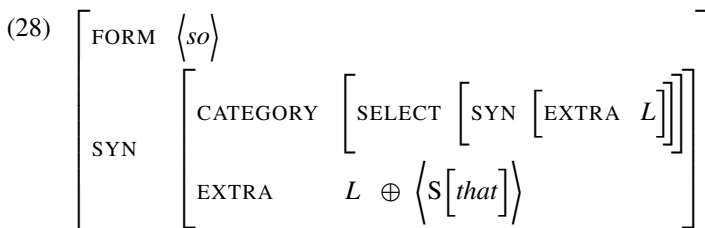

The SELECT value of the degree marker spells out that it selects a head sister, usually an adjectival or adverbial sign, and its EXTRA value contains the information that it also selects a *that*-clause. The listeme also foresees the possibility that the head sister already has something on its EXTRA list (*L*) and makes sure that it is also present in the EXTRA list of the degree marker. This is relevant to deal with the dependencies in (29).

- (29) Kim was [[so much more satisfied] than the last time] that he couldn't stop smiling.

In this sentence, *so* selects a head sister that already contains another degree marker *more*. The EXTRA value of the latter, which is an elliptical *than*-clause, is added to the EXTRA list of *so*.

To model the combination of a clause and an extraposed constituent, the authors add a phrasal construct to the hierarchy, called *head-extra-cxt*. The properties of such phrases are spelled out in terms of the combinatoric construction in (30).

(30) **Head-Extrapolation Construction:**

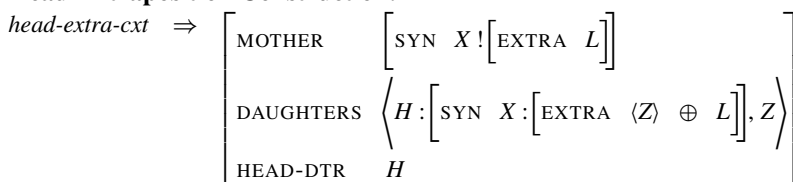

The head daughter (*H*) has an EXTRA list whose first member (*Z*) is matched with the non-head daughter, and the mother's SYN value is identical to that of the head daughter except for (!) the fact that *Z* is no longer in the EXTRA list.

Turning to the treatment of the **complex predeterminers**, the challenge is to account for the fact that, on the one hand, pronominal adjectives canonically select

a bare nominal (*big mess*) rather than an NP (* *big a mess*), while, on the other hand, the prenominal APs that are introduced by a degree marker, such as *so*, select a nominal that is introduced by the indefinite article (*so big a mess*) rather than a bare nominal (* *a so big mess*).

In the HPSG treatment of Van Eynde (2007), this is dealt with in two steps: the combination of the degree marker with the adjective is treated as a regular instance of the head-functor type, and the combination of the resulting AP with the indefinite NP is treated in terms of an idiosyncratic phrase type, called the *big-mess-phrase*. The SBCG treatment of Kay & Sag (2012) does it the other way round: it treats the combination of the AP with the indefinite NP as a regular instance of the head-functor type, and introduces an idiosyncratic type of construct for the combination of the degree marker with the adjective, the so-called *complex-predeterminer-cxt* (p. 238). The difference between the two treatments is small, but the former has the advantage of greater generality, since it treats the combination of the degree marker with the adjective in the same way, no matter whether it is used as a complex predeterminer (*so big a mess*), as a predicative AP (*is so big that it does not fit*) or as a postnominal modifier (*houses so big that they are hard to sell*). Kay & Sag (2012), by contrast, have a different treatment for the predeterminer than for the homophonous predicative AP and postnominal modifier.¹⁷

3.2 *The distribution of that-clauses in English: An SBCG account*

The contribution by Gert Webelhuth (pp. 203–227) addresses the thorny issue of the distribution of *that*-clauses. To give an idea of what the problems are he draws the attention to the filler–gap mismatch in (31).

- (31) (a) [That we won't abandon him]_i you may definitely depend on ..._i.
 (b) * You may definitely depend on [that we won't abandon him].

(31a) shows that a *that*-clause can be preposed from the complement position of a preposition, but (31b) shows that that same clause cannot be used in the complement position of the preposition. For the clausal complements of certain verbs and adjectives, the facts are the other way round.

- (32) (a) Mary informed Bill [that Sue was late again].
 (b) * [That Sue was late again]_i Mary informed Bill ..._i.
 (33) (a) He was unhappy [that Sue was late again].
 (b) * [That Sue was late again]_i he was unhappy ..._i.

[17] Kim & Sells (2011) present a third possibility. They treat both combinations as regular instances of the head-functor type, but in order to make this work, they change the definition of the type.

At the same time, there are also verbs that allow their clausal complement to be preposed, such as *find* in (34).

(34) [That Sue was late again]_i we didn't really find ____i very surprising.

Adding to the complexity are the data about the subject *that*-clauses in (35).

- (35) (a) [That John showed up] pleased me.
 (b) * Did [that John showed up] please you?
 (c) * [That [that John showed up] pleased her] is obvious.
 (d) * I don't know [how well known [that the world is round] is]
 (e) * How likely is [that John showed up]?

Apparently, subject *that*-clauses are allowed in clause-initial position, as in (35a), but not in any other position.

To account for these facts Webelhuth makes two assumptions. The first one is that *that*-clauses can only be preposed from positions in which proposition denoting NPs can occur. The anaphoric *that*, for instance, can be used as the complement of a preposition or a verb like *find*, but not as the complement of a predicative adjective or a verb like *informed*.

- (36) (a) We won't abandon him. You may depend on that.
 (b) Sue was late again. We didn't really find that very surprising.
 (c) * Sue was late again. He was unhappy that.
 (d) * Sue was late again. Mary informed Bill that.

The second assumption is that *that*-clauses cannot be realized in subject position. Instead, the *that*-clauses that realize the first argument of a verb like *please*, must appear in a left peripheral position. This echoes a position already advocated in transformational grammar in Koster (1978). In SBCG terms it implies that subject *that*-clauses are fillers which combine with a gapped main clause, as in (37).

(37) [That John showed up]_i --_i pleased me.

The ill-formedness of the other combinations in (35) is due to the fact that the *that*-clauses in those strings are not preposed. Further evidence for the preposed nature of the *that*-clause in (37) is provided by the fact that its place can be taken by the demonstrative anaphor, as in (38).

(38) John showed up. That pleased me.

To model his two assumptions in formal terms, Webelhuth proposes the construction in (39) (p. 221).¹⁸

[18] Webelhuth's representation format is a mix of SBCG and constructionist HPSG, but a conversion into SBCG would be trivial. IC is short for 'independent clause'.

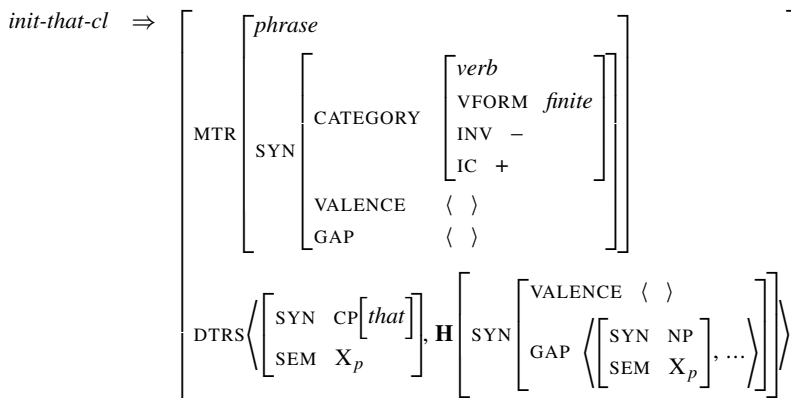
(39) **Initial-that-Clause Construction:**

This construction licenses the combination of a preposed *that*-clause with a finite main clause that has an NP gap with propositional semantics. The fact that the gap must be an NP while the preposed clause must be a CP captures the filler–gap mismatch. At the same time, it differentiates the well-formed combinations with a preposition or a verb like *find* in (31) and (34) from the ill-formed combinations with a predicative adjective or a verb like *inform* in (32) and (33). It also licenses the combination with the subject clause in (35a), but it does not allow any of the other combinations in (35), since the *that*-clauses in those sentences do not occur in the filler position.

The construction in (39) is a nice illustration of how the bewildering facts about the distribution of *that*-clauses can be modeled in SBCG, thus providing extra evidence for the latter’s flexibility. What is missing, though, is an indication of where the initial *that*-clause constructs belong in the type hierarchy of constructs. If added, this might simplify the definition of the construction in (39), as some of it could probably be inherited from supertypes, such as the *filler-head-cxt*.

4. LANGUAGE USE AND LANGUAGE CHANGE

One of the declared aims of SBCG is to make sure that its ‘linguistic proposals are motivated and evaluated in terms of how well they comport with models of language use, language learning and language change’ (p. 14). Two of the papers in the volume address these issues. More specifically, the one about FrameNet focuses on the interaction with models of language use, and the one about the comparative method focuses on the interaction with models of language change. They are presented in Sections 4.1 and 4.2 respectively.

4.1 *The FrameNet Constructicon*

This contribution by Charles Fillmore, Russell Lee-Goldman and Russell Rhomieux (pp. 309–372) provides a link between SBCG and language use. Taking its cue from the corpus-based construction of the FrameNet Lexicon

(Fillmore & Baker 2010), the paper shows how the approach can be extended to sample and describe constructions, yielding an embryonic FrameNet Constructicon. The paper first presents the FrameNet methods and annotation guidelines, and then proceeds with the discussion of 14 different constructions. In keeping with the CxG tradition, they are all constructions with idiosyncratic or non-compositional properties. For four of them, the authors provide both a FrameNet entry and an SBCG description. One of these concerns the use of adjectives as nominals, as in (40).

- (40) (a) Examine the plight of the very poor.
 (b) Their outfits range from the flamboyant to the functional.
 (c) The unimaginable happened.

The examples each illustrate a different subconstruction, called respectively *Human*, *Anaphoric* and *Abstract*. The first one is assigned the following FrameNet entry (p. 358).¹⁹

- (41) {*NP.plural* [*the*] [*AP*] }

Name	<i>Adjective-as-nominal.Human</i>
M	NP, plural, generic reference
D1	the word <i>the</i>
D2	an AP describing a property of people

- (42) (a) She is friend to {*NP* [*the*] [*AP* poor]}
 (b) {[The] [hard of hearing]} are sure to appreciate this new device.

[19] A FrameNet entry consists of two parts. One is a description of the construction, spelled out in terms of conditions on the mother and its daughters. The other is a set of annotated examples from the corpus (p. 347).

The corresponding SBCG description looks as follows (p. 359):

(43) **Adjective as Nominal (Human) Construction:**

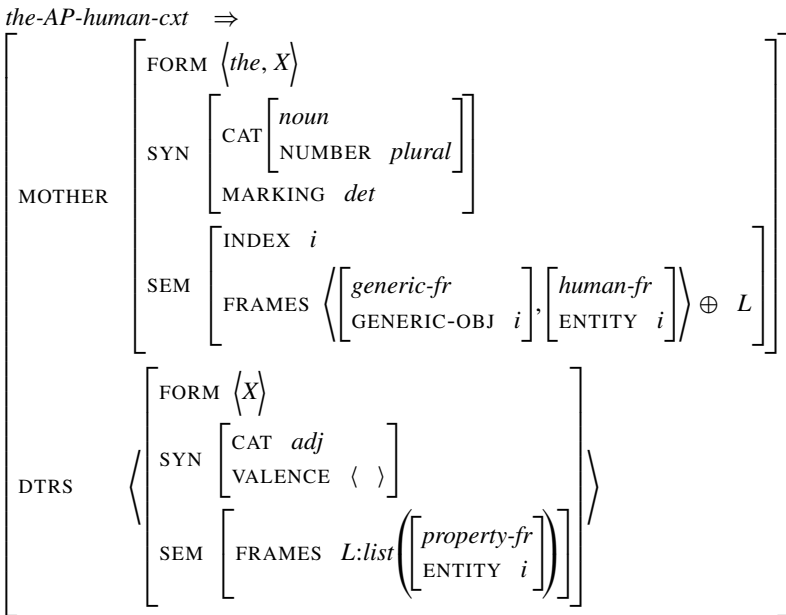

This construction licenses constructs in which a fully saturated AP is turned into a plural definite NP that denotes humans and that has a generic interpretation. The definite article is not treated as a separate daughter, but syncategorematically introduced. Whether the restriction to *the* is justified is questioned by the authors themselves, quoting combinations such as *England's poor* and *the state's persistently unemployed*, which suggest that possessive NPs may also fit the bill. The matter is, however, left in the air, as is much else about the FrameNet Constructicon.

In principle, it could provide the SBCG community, or the linguistics community at large, with a catalogue of constructions that require special attention and with an informal but well documented indication of what it is that makes them special. In its present stage, however, the constructicon is mainly the result of a cherry-picking approach (the authors' own words, p. 369) that is guided by linguists' intuitions about idiosyncrasy and by an assessment of the existing CxG literature. There is no procedure for culling the relevant constructions from a corpus in a (semi)automatic manner. That is admittedly not an easy task, but it is not impossible either. If one employs a treebank in which the corpus is analyzed by a parser, and not merely tagged as in the FrameNet case, and if the parser is well documented and geared toward the analysis of the regular and the compositional, then the combinations that the parser cannot deal with are good candidates for inclusion in the Constructicon.

4.2 *Reconstructing syntax: construction grammar and the comparative method*

The contribution by Jóhanna Barddal and Thórhallur Eythórsson (pp. 257–308) addresses the link between (Sign-Based) Construction Grammar and matters of language change. More specifically, it aims to show that Construction Grammar, and SBCG in particular, provides the means to broaden the historical-comparative method, which is usually confined to matters of phonology, morphology and lexicology, to matters of syntax and the syntax/semantics interface.

In the same way that form–function pairings are crucial for establishing relations between words of different languages and for the reconstruction of proto-words, see Meillet (1925), it is assumed that form–function pairings at the level of phrasal constructs are crucial for establishing relations between constructs of different languages and for the reconstruction of proto-constructs:

a resurgence of syntactic reconstruction is made possible by the development of the theory and framework of Construction Grammar, where objects once regarded as purely syntactic are viewed as form–function or form–meaning pairings, like words. This view of syntax makes ‘syntactic structures’ a legitimate object of the Comparative Method, as syntactic structures in this framework consist of a form side and a function side, just as words do. (p. 258)

The article first dwells on methodological issues and on possible objections against the application of the comparative method to syntax. It then focuses on a particular topic, i.e. the dative subject construction in Germanic languages. Employing data from Modern Icelandic, it is argued that the verbs that select a dative subject belong to two semantic classes: the experience-based predicates, comprising verbs such as *like*, and the happenstance predicates, comprising verbs such as *succeed*. They are further partitioned in a number of subtypes, see Table 1.

Experience-based		Happenstance	
Emotions	<i>like</i>	Success	<i>succeed</i>
Attitudes	<i>be easy for sb.</i>	Gain	<i>receive</i>
Cognition	<i>suspect</i>	Failure	<i>fail</i>
Perception	<i>taste</i>	Properties	<i>be natural</i>
Bodily States	<i>bleed</i>	Decline	<i>deteriorate</i>
Changes in Bodily States	<i>become sick</i>	Existence	<i>be</i>
		Social Interaction	<i>be friends</i>

Table 1
Verbs which take a dative subject in Modern Icelandic.

On carrying out the same exercise for Faroese and German, it turns out that the verbs that take a dative subject in German are a proper subset of the Icelandic set (6 + 4 subtypes), and that the Faroese ones are in turn a proper subset of the

German set (3 + 3 subtypes).²⁰ Moreover, a corpus-based comparison with Old Norse-Icelandic shows that the class of verbs with a dative subject has shrunk over time: from 18.4% of the verbs in a sample of Old Norse-Icelandic texts to 10.3% in a comparable sample of Modern Icelandic texts. This correlates with an almost equal increase of verbs with a nominative subject: from 76.3% in the Old Norse-Icelandic sample to 85% in the Modern Icelandic one. This strongly suggests that Proto-Germanic had a dative subject construction and that the number of verbs that it subsumed was a superset of that of Modern Icelandic.

While this is an interesting and plausible conclusion, the main question in this context is whether the use of SBCG has been instrumental in obtaining it. This is a legitimate question, since the authors explicitly claim in the concluding section that

the ultimate goal of this paper has been to demonstrate that the tools of CxG provide us with a principled approach to reconstructing grammar, and hence ‘syntax’, based on form–function pairings. In particular, the SBCG formalism provides the precision and coverage needed to reconstruct grammar. (p. 300)

Looking at the paper from that perspective, the evidence is underwhelming. The few traces of SBCG in the paper are the partial hierarchy of verbal lexemes in (44) and the lexical class constructions in (45).²¹

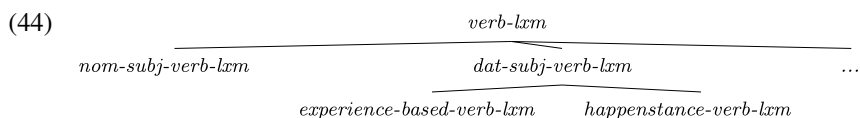

- (45) (a) *dat-subj-verb-lxm* ⇒ $\left[\text{SYN} \left[\text{CAT} \left[\text{XARG NP} \left[\text{dative} \right] \right] \right] \right]$
- (b) *experience-based-verb-lxm* ⇒ $\left[\text{SEM} \left[\text{FRAMES} \left\langle \left[\text{exp-fr} \right] \right\rangle \right] \right]$
- (c) *happenance-verb-lxm* ⇒ $\left[\text{SEM} \left[\text{FRAMES} \left\langle \left[\text{happen-fr} \right] \right\rangle \right] \right]$

There are no constructions for the subtypes of the two semantic classes. Besides, the few lexical class constructions in (45) curiously defeat the authors’ own purpose: the one for dative subject constructions has a syntactic constraint but no semantic one, and the ones on its two subtypes have a semantic constraint but no syntactic one. In other words, they are not constraints on form–meaning

[20] As pointed out by an anonymous reviewer, the assumption that German has dative subjects is controversial.

[21] The other subtypes of *verb-lxm* in (44) are *accusative-subject-verb-lxm* and *genitive-subject-verb-lxm*.

pairings, but either on form or on meaning. This is not a problem for SBCG, since it explicitly allows constructions to exclusively constrain form or meaning, as pointed out in [Section 2.4](#), but it is a problem for the claim of the authors that one needs form–meaning pairings in order to apply the historical-comparative method.

5. CONCLUSION

Sign-Based Construction Grammar (SBCG) is a blend of Construction Grammar, especially Berkeley Construction Grammar, and Head-driven Phrase Structure Grammar, especially the constructionist version familiar from Sag (1997) and Ginzburg & Sag (2000). The homophonous book provides an excellent introduction to the framework in Ivan Sag's contribution ([Section 2](#)) and two convincing case studies ([Section 3](#)). The papers on language use and language change are a welcome addition, but the link with SBCG is too thin for them to serve as showcases of how SBCG opens up new perspectives in corpus-based work and in diachronic syntax ([Section 4](#)).

The contribution by Laura Michaelis, 'Making the case for construction grammar' (pp. 31–67), and the opening text by Ivan Sag, Hans Boas and Paul Kay, 'Introducing Sign-Based Construction Grammar' (pp. 1–29), are not so much contributions to SBCG as comparisons of SBCG with other frameworks. Both papers argue why SBCG is superior to other variants of construction grammar, including Berkeley Construction Grammar, and do this with partly identical arguments, such as the localist nature of SBCG and its treatment of inheritance as a type-based device. They also both argue why SBCG is superior to Transformational Grammar, stressing the fact that the compositional and the idiosyncratic are so much interwoven that the distinction between core and periphery is untenable. What is missing is a comparison with constructionist HPSG. Advocates of the latter will find little justification for a wholesale conversion, but they will find a wealth of ideas and analyses which deserve incorporation in mainstream HPSG.

REFERENCES

- Allegranza, Valerio. 1998. Determiners as functors: NP structure in Italian. In Sergio Balari & Luca Dini (eds.), *Romance in HPSG*, 55–107. Stanford, CA: CSLI Publications.
- Allegranza, Valerio. 2007. *The signs of determination: Constraint-based modelling across languages*. Frankfurt am Main: Peter Lang.
- Bergen, Benjamin & Nancy Chang. 2009. Embodied Construction Grammar in simulation-based language understanding. In J.-O. Östman & M. Fried (eds.), *Construction Grammars: Cognitive grounding and theoretical extensions*, 147–190. Amsterdam: John Benjamins.
- Boas, Hans C. & Ivan A. Sag (eds.). 2012. *Sign-Based Construction Grammar*. Stanford, CA: CSLI Publications.
- Bouma, G. 1996. Extraposition as a nonlocal dependency. *Proceedings of Formal Grammar 96*, 1–14. UC Berkeley: Prague.
- Bresnan, Joan (ed.). 1982. *The mental representation of grammatical relations*. Cambridge, MA: MIT Press.
- Bresnan, Joan. 2000. *Lexical Functional Syntax*. Oxford: Blackwell.
- Croft, W. 2001. *Radical construction grammar: Syntactic theory in typological perspective*. Oxford: Oxford University Press.

- de Saussure, Ferdinand. 1916. *Cours de linguistique générale*. Paris: Payot.
- di Sciullo, Anna Maria & Edwin Williams. 1987. *On the definition of word*. Cambridge, MA: MIT Press.
- Fillmore, Charles & Collin Baker. 2010. A frames approach to semantic description. In B. Heine & H. Narrog (eds.), *The Oxford handbook of linguistic analysis*, 313–339. Oxford: Oxford University Press.
- Fillmore, Charles & Paul Kay. Unpublished. *Construction grammar coursebook*.
- Fillmore, Charles, Paul Kay & Mary O'Connor. 1988. Regularity and idiomaticity in grammatical constructions: The case of *let alone*. *Language* 64, 501–538.
- Gazdar, Gerald, Ewan Klein, Geoff Pullum & Ivan A. Sag. 1985. *Generalized phrase structure grammar*. Oxford: Basil Blackwell.
- Ginzburg, Jonathan & Ivan A. Sag. 2000. *Interrogative investigations*. Stanford, CA: CSLI Publications.
- Goldberg, Adele. 1995. *Constructions: A construction grammar approach to argument structure*. Chicago: Chicago University Press.
- Goldberg, Adele. 2006. *Constructions at work: The nature of generalization in language*. Oxford: Oxford University Press.
- Goldberg, Adele. 2009. The nature of generalization in language. *Cognitive Linguistics* 20, 93–127.
- Kay, Paul & Charles Fillmore. 1999. Grammatical constructions and linguistic generalizations: The 'what's x doing y?' construction. *Language* 75, 1–33.
- Kay, Paul & Ivan A. Sag. 2012. Cleaning up the big mess: Discontinuous dependencies and complex determiners. In Boas & Sag (eds.), 229–256.
- Kim, Jong-Bok & Ivan A. Sag. 2005. English object extraposition: A constraint-based approach. In Stefan Müller (ed.), *Proceedings of the 12th International Conference on Head-driven Phrase Structure Grammar*, 192–212. Stanford, CA: CSLI Publications, Stanford University.
- Kim, Jong-Bok & Peter Sells. 2011. The big mess construction: Interaction between the lexicon and constructions. *English Language and Linguistics* 15, 335–362.
- Koster, Jan. 1978. Why subject sentences don't exist. In S. Keyser (ed.), *Recent transformational studies in European languages*, 53–64. Cambridge, MA: MIT Press.
- Lakoff, G. 1987. *Women, fire and dangerous things*. Chicago: University of Chicago Press.
- Langacker, R. 1987. *Foundations of cognitive grammar: Theoretical prerequisites*. Stanford, CA: Stanford University Press.
- Meillet, Antoine. 1925. *La méthode comparative en linguistique historique*. Paris: Champion.
- Müller, Stefan. 2015. *Grammatical theory: From transformational grammar to constraint-based approaches*. Berlin: Language Science Press.
- Pollard, Carl & Ivan A. Sag. 1987. *Information-based syntax and semantics*. Stanford, CA: CSLI Publications.
- Pollard, Carl & Ivan A. Sag. 1994. *Head-driven Phrase Structure Grammar*. Stanford/Chicago: CSLI Publications and University of Chicago Press.
- Sag, Ivan A. 1997. English relative clause constructions. *Journal of Linguistics* 33, 431–484.
- Sag, Ivan A. 2012. Sign-Based Construction Grammar: An informal synopsis. In Boas & Sag (eds.), 69–202.
- Steels, Luc (ed.). 2011. *Design patterns in fluid construction grammar*. Amsterdam: John Benjamins.
- Van Eynde, Frank. 1996. An HPSG treatment of *it* extraposition without lexical rules. In G. Durieux, W. Daelemans & S. Gillis (eds.), *Clin vi. Papers from the Sixth Clin Meeting*, 231–248. Antwerpen: CNTS, University of Antwerp.
- Van Eynde, Frank. 1998. The immediate dominance schemata of HPSG. In Peter-Arno Coppen, Hans van Halteren & Lisanne Teunissen (eds.), *Computational linguistics in the Netherlands 1997*, 119–133. Amsterdam/Atlanta: Rodopi.
- Van Eynde, Frank. 2006. NP-internal agreement and the structure of the noun phrase. *Journal of Linguistics* 42, 139–186.
- Van Eynde, Frank. 2007. The big mess construction. In Stefan Müller (ed.), *Proceedings of the 14th International Conference on Head-driven Phrase Structure Grammar*, 415–433. Stanford, CA: CSLI Publications, Stanford University.

Author's address: Department of Linguistics, University of Leuven,
Blijde Inkomststraat 21,
3000 Leuven, Belgium
frank.vaneynde@ccl.kuleuven.be