

High power laser interaction with clusters

TARA DESAI

Dipartimento di Fisica, Università degli Studi di Milano–Bicocca, Via Emanuelli, 15-20126, Milano, Italy

(RECEIVED 30 November 2000; ACCEPTED 5 February 2001)

Abstract

Response of clusters to laser radiation depends on the laser parameters like wavelength, pulse duration, field, and so forth. At moderate laser intensities, $I \sim 10^{12}$ W/cm², using a laser beam of wavelength 1.06 μm and 10-ns pulse duration, we have studied X-ray emission spectra from aluminum clusters of diameter 0.4 μm and gold clusters of 1.25 μm . Aluminum clusters show a different spectra compared to bulk material whereas gold clusters evolve towards bulk gold. Results are analyzed on the basis of cluster dimension, laser wavelength, and pulse duration. At higher laser intensities $\geq 10^{18}$ W/cm², clusters undergo Coulomb explosion, giving rise to energetic electrons and ions. Here we discuss the possibility of harnessing these energetic particles for heating a small volume of the precompressed DT fuel to ignition condition relevant to fast ignition. Preliminary results are discussed.

1. INTRODUCTION

Clusters occupy the region between atoms/molecules, monomers, and condensed phase (Hagena, 1992) and they exist in solid, liquid, and gas phase (Mark, 1987). They are an aggregate of a large number of identical atoms/molecules. Response of an individual atom to the laser radiation depends on the laser field along with the electron configuration of the target atom, while that of the bulk material is the collective response of all the atoms as a whole. Therefore, the study of clusters provides valuable information about how the properties of matter change as one progresses from a single atom to that of solid material (Hutchinson, 1998). Although clusters are a less well-studied state of matter, there are some important observations about cluster behavior, for example, cluster size stabilizes with a definite number of atoms which is called a magic number (Kardt, 1984; Knight *et al.*, 1984). The total binding energy, average binding energy per unit, and individual binding energy of successive clusterings are of great importance in determining stability and structure of a cluster ion (Mark, 1987). Melting temperature is a thermodynamic property of matter. When a gold cluster is less than 100 Å in radius, the melting temperature is lower than that of the bulk gold material (Mark, 1987). Hg_n clusters exhibit metallic behavior (Brechignac *et al.*, 1985) with $n \geq 8$. Metallic conductivity is important in miniaturizing the size of the semiconductor devices. When

small clusters start displaying bulk properties implies a changing of ionization energies, hence work function, and affinity of metallic clusters (Mark, 1987).

In recent years, there has been a significant interest in understanding the physics of ultra short ($\sim\text{fs}$) and intense ($I > 10^{15}$ W/cm²) interaction with clusters. Much work has been reported using gas-jet-produced clusters at high laser irradiance. However, the purpose of all this research has been directed toward the generation of higher order harmonic conversion (Jeffrey *et al.*, 1992; Tisch *et al.*, 1997), energetic ion generation (Ditmire *et al.*, 1998; Eloy *et al.*, 1999), anomalous X-ray generation (McPherson *et al.*, 1994; Thomson *et al.*, 1994; Tisch *et al.*, 1997), as a diagnostic tool for high density, high temperature plasma, and so forth. Some of the interesting behavior of the clusters has been revealed during this research, like cluster sputtering (Mathew *et al.*, 1986), specific charge of cluster ions (Mark, 1987), dissociation dynamics (Lezius *et al.*, 1998), cluster explosion (Ditmire *et al.*, 1998; Lezius *et al.*, 1998) and so forth. In the first part of this report, we present our experimental study on X-ray emission by irradiating metal clusters like aluminum and gold at moderate intensities, $I \sim 10^{12}$ W/cm². These spectra are compared with the spectra from respective bulk materials. Metallic clusters are commercially available and their density is similar to that of solid material. Experimental results are analyzed on the basis of laser pulse duration and cluster size. In the second part, we discuss the possibility of using energetic particles generated due to ultra-intense laser ($I \geq 10^{18}$ W/cm²) interaction with clusters for the study of fast ignition. These results are also discussed briefly in our earlier work (Desai *et al.*, 2000).

Address correspondence and reprint requests to: Tara Desai, Dipartimento di Fisica, "G. Occhialini" and INFN, Università degli Studi di Milano–Bicocca, Via Emmanuelli 15 (Piazza della Scienza 3), 20126 Milano, Italy. E-mail: tara.desai@mi.infn.it.

2. MODERATE INTENSITY LASER-CLUSTER INTERACTION AND X-RAY GENERATION

2.1. Experiments

Experiments were performed using a laser radiation of wavelength $\lambda_L = 1.06 \mu\text{m}$ with optical energy $E_L < 1 \text{ J}$ with 10-ns (FWHM) duration. Two types of targets were used: Slab targets of aluminum and gold, (2) Cluster targets where clusters of aluminum and gold were embedded in polymers. A known quantity of aluminum clusters with an average diameter $C_{da} \sim 0.4 \mu\text{m}$ or gold clusters of average diameter $C_{dg} \sim 1.25 \mu\text{m}$ were homogeneously mixed in a polymer base solution and thin films of $\sim 10\text{-}\mu\text{m}$ thickness were fabricated for the present study. Here we consider two cases where cluster diameter is less than the laser wavelength ($C_d < \lambda_L$ in the aluminum cluster) and secondly, of the order or larger than laser wavelength ($C_d \geq \lambda_L$ in the case of gold cluster).

These targets were placed at the center of the plasma chamber evacuated to 10^{-5} torr of atmospheric pressure. Laser radiation was focused to $\sim 100 \mu\text{m}$ in diameter. X-ray emission spectra in the range of 5–22 nm were recorded at 45° to target normal using a grazing incidence spectrometer having 1200 lines/mm flat field grating coupled with a back-side illumination type CCD camera. CCD was cooled to -30°C . The experimental setup is shown in Figure 1. This work was also described in an earlier article (Desai & Pant, 2000) and the detailed analysis of the earlier spectra are presented here in a different perspective. X-ray emission spectra from cluster targets were compared with that of slab targets to check the cluster behavior during the process of X-ray emission.

The number of atoms, $n \approx (R_c/r)^3$, in each of the above clusters was $\sim 8 \times 10^9$ and $\sim 10^{11}$, respectively, where R_c and r correspond to cluster radius and radius of the atom.

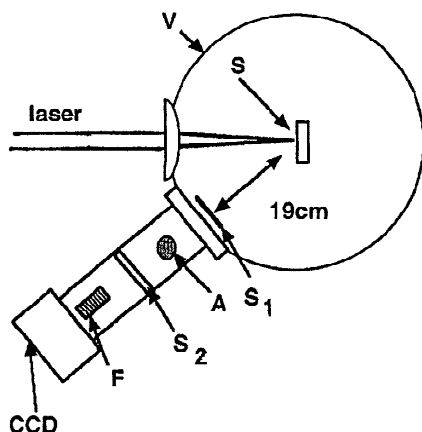

Fig. 1. Schematic of the experimental setup. V: vacuum chamber, S: solid target, S1: external slit ($100 \mu\text{m}$ width), A: gold coated spherical mirror, S2: Slit $300 (\mu\text{m})$ width, F: flat field grating (1200 lines/mm), and CCD: Black illumination type CCD camera.

Since we have used 50 mg of aluminum clusters by weight per cubic centimeter of polymer, the number of clusters is $\sim 5.5 \times 10^{11}/\text{cc}$ and the distance between two clusters (center to center) is $A = \text{intercluster spacing} = (3/4\pi n)^{1/3} \approx 0.755 \mu\text{m}$. Since $A >$ diameter of the cluster, we can assume each aluminum cluster behaves independently. Similarly the density of the gold cluster of diameter $\sim 1.25 \mu\text{m}$ is $\sim 2.6 \times 10^9/\text{cc}$ with interspacing of gold clusters at $\sim 4.0 \mu\text{m}$. Thus, the interaction of the gold cluster with the laser beam can also be treated as a single cluster interaction. With the onset of laser beam, each cluster within the focal spot area will experience uniform radiation field.

2.2. Results

Aluminum clusters of an average diameter of $\sim 0.4 \mu\text{m}$ embedded in polymer solution show negligible X-ray intensity in the 5–22 nm spectral range as shown in Figure 2a. Similar values are presented in Figure 2b for a pure aluminum slab target. It is clear that X-ray emission spectra for cluster targets do not match in shape and intensity with that of the aluminum slab target. Continuum emission spectra for both the targets are expected due to free-free or free-bound radiation from the plasma. The experimental results indicate the aluminum clusters of diameter ($\sim 0.4 \mu\text{m} < \lambda_L$) do not behave like bulk material. That the shape of the spectra of the aluminum cluster is not identical to bulk material indicates that the plasma ionization level in cluster is different than that of the bulk material under identical experimental conditions. In contrast to this, a gold cluster target (Fig. 3a) with an average cluster diameter of $\sim 1.25 \mu\text{m}$, embedded in polymer base and under identical experimental conditions, emits a continuum which is nearly similar in shape to that of the bulk gold target (Fig. 3b), but has lower intensity. This means the process of X-ray emission from the gold cluster of a diameter of $\sim 1.25 \mu\text{m} > \lambda_L$ is approximately similar to that of bulk material.

2.3. Discussion

We assume the laser interaction with a cluster is similar to that of the laser interaction with a small ball of solid material and the mechanism of plasma production from the cluster will be similar to that of bulk material. This assumption is valid provided the cluster dimension is significantly larger than Debye length $\lambda_D = (KT/4\pi ne^2)^{1/2}$ (Ditmire *et al.*, 1996) and all the plasma conditions have been satisfied to define a cluster plasma. With the onset of laser radiation on the cluster, the cluster experiences a uniform radiation field throughout and electrons oscillate with a quiver velocity $V_{osc} = eE/m\omega_L$, producing a solid density plasma. During their oscillation, electrons collide with neighboring atoms and heat the entire cluster. The cluster is heated predominantly by electron-ion collisions and the hydrodynamic expansion of the plasma from the cluster surface results in the decrease of plasma density. In the case of planar targets,

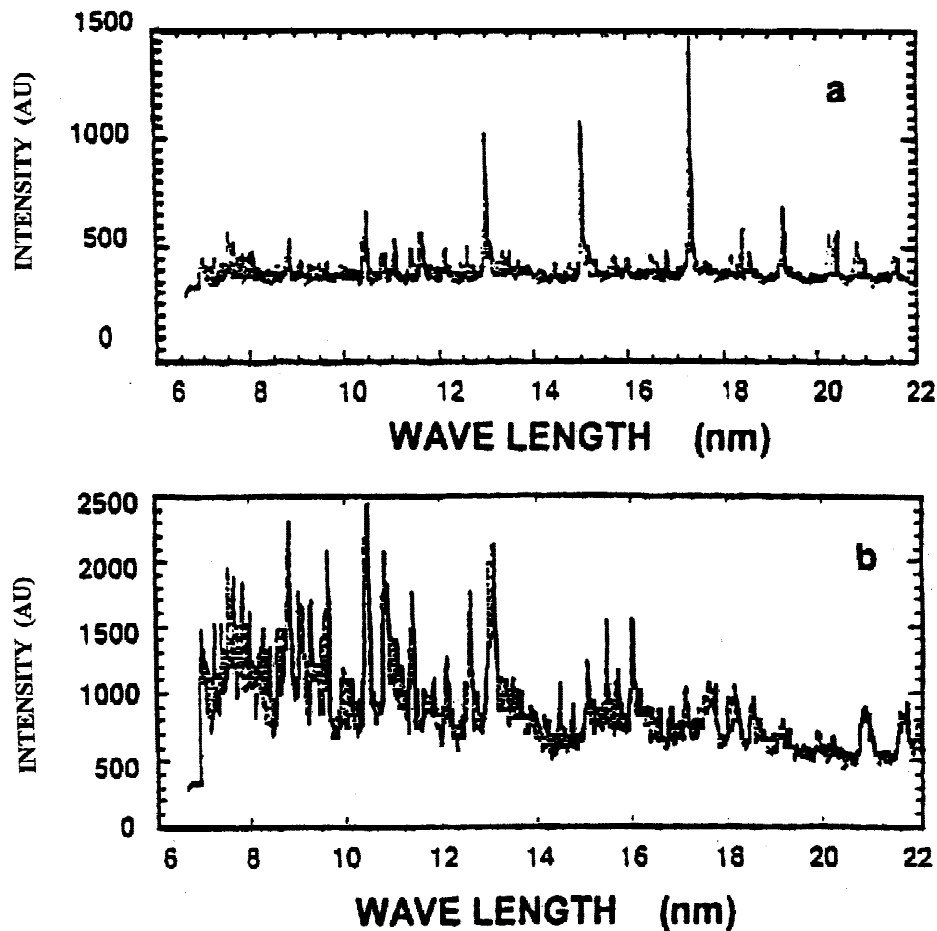

Fig. 2. (a) X-ray intensity (AU) versus X-ray wavelength for aluminum cluster target. (b) X-ray intensity (AU) versus X-ray wavelength for aluminum slab target.

absorbed laser energy is transported from the critical density surface to the corona to maintain plasma expansion and inward for target ablation. Similarly, the inward energy transport into the cluster is responsible for further heating of the cluster as a whole. For planar targets, plasma density falls to $1/e$ times the critical density at a distance $L \sim 2R$ (Max, 1982), where R is the laser focal spot radius, but in the case of clusters, this distance depends on two factors. (1) Plasma density decreases exponentially from the cluster surface due to hydrodynamic expansion of the surface plasma, similar to a slab target with a velocity $V \sim (KT_e)^{1/2}$ where KT_e is the temperature of the plasma on cluster surface. (2) Simultaneously, the cluster as a whole expands in all directions due to its internal pressure $P_i + P_e = (nkT)_i + (nkT)_e$ and increases in size. This leads to cluster disassembly. The time required for a cluster to disassemble is known as disassembly time, $t_d = C_d/2C_s$, where C_d is the cluster diameter and $C_s = (ZKT_e/m_i)^{1/2}$. Maximum plasma temperature T_e depends on the effective laser energy deposition on the cluster surface on a time scale comparable to the cluster disassembly time, the cluster dimension, its mass density, laser intensity, pulse duration, and so forth.

These experimental results raise a question: Why does a cluster, a fragment from a bulk material having a dimension smaller than the incident laser wavelength, behave differently than the bulk in the present investigation reported here? With increased cluster diameter, more than the laser wavelength, cluster behavior evolves towards the bulk material. Therefore, we have analyzed our results on the basis of cluster dimension and laser pulse duration. We believe that there can be several reasons to explain these results.

2.3.1. Case 1. $C_{da} < \lambda_L$, aluminum cluster

In our present case, the aluminum cluster has a diameter $C_{da} < \lambda_L/2$. At the beginning of the laser pulse, electrons of the entire cluster as a whole will respond to the electric field. Since clusters are independent entities, free electrons will oscillate in the direction of EF in half the cycle and in the opposite direction in the remaining half of the cycle of the wave. This will create a giant dipole (Hutchinson, 1998). As the cluster is similar to a solid surface, various interaction processes that occur on the time scale of the laser pulse are laser ionization, laser absorption, X-ray generation, cluster expansion, and so forth. Laser radiation is predominantly

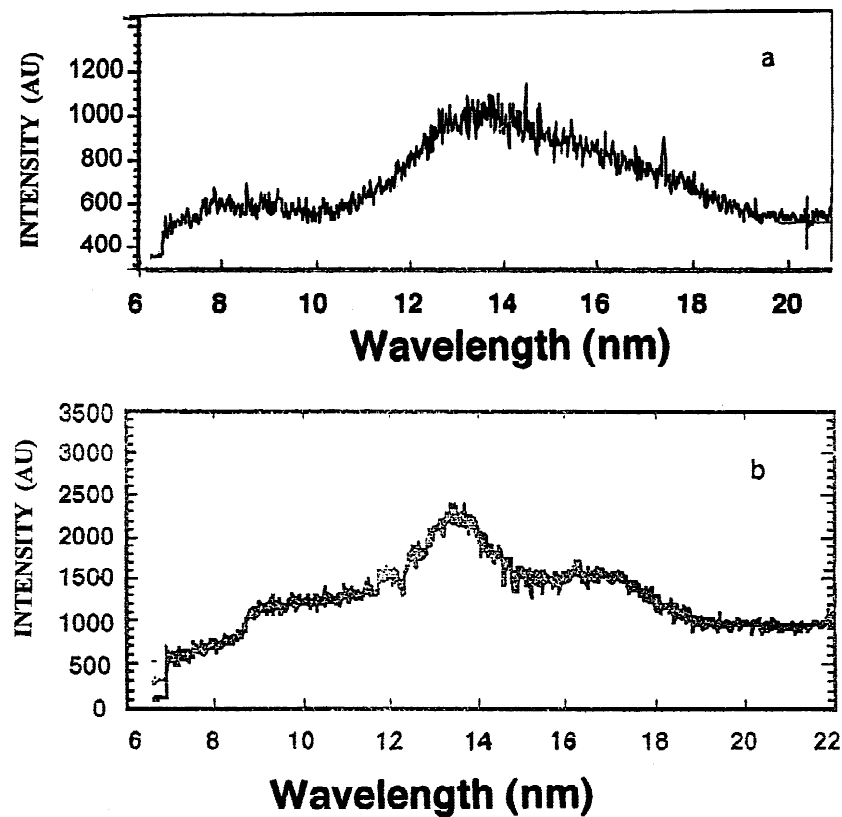

Fig. 3. (a) X-ray intensity (AU) versus X-ray wavelength for gold cluster target. (b) X-ray intensity (AU) versus X-ray wavelength for solid gold target.

absorbed by inverse bremsstrahlung. The incident laser radiation becomes evanescent at a distance $\delta (= C/\omega_p) > C_{da}$. Ablation depth (Desai, 1992) for an aluminum slab target at $I \sim 10^{12}$ W/cm² is ~ 0.4 μ m, which is comparable to the cluster diameter. As discussed above, due to cluster disassembly, plasma density falls below the critical value n_c and cluster disassembly time is much smaller than laser pulse duration (10 ns). Since the laser pulse is still on, the remaining laser radiation penetrates the cluster plasma without being absorbed. Therefore no significant laser energy is deposited on the cluster surface and a large fraction of laser radiation transmits through the diluting cluster plasma.

Thus in the case of the aluminum cluster of diameter ~ 0.4 μ m, (1) plasma density and temperature are not very high, hence there is a low X-ray yield; (2) the radiation mean free path (Zeldovich & Raiser, 1966) for a slab target at $I \sim 10^{12}$ W/cm² is $\lambda_R \sim 3$ μ m, which is larger than the dimension of the cluster; this implies that initial X rays will transmit through the plasma. Thus, further X rays cannot be generated due to the down conversion mechanism similar to solid targets. For the above mentioned reasons, we believe that the X-ray yielding process in cluster plasma is not the same as that in the solid aluminum target. Therefore, the shape of the X-ray emission spectra is different and X-ray intensity is less than that of solid target.

2.3.2. Case 2. $C_{da} \geq \lambda_L$, gold cluster

Here the gold cluster diameter is $C_{dg} > \lambda_L$. That is, the laser wave experiences evanescence inside the cluster within the skin depth $\delta = \lambda_L$. We assume the behavior of such a cluster is like that of the bulk target for the following reasons. Ablation depth for a planar gold target $I \sim 10^{12}$ W/cm² is ~ 1.2 μ m, which was estimated from ablation pressure reported in our earlier work (Godwal *et al.*, 1989; Desai, 1992) and is comparable to the cluster dimension. Ablation depth in the gold target is higher due to radiation transport. Laser radiation becomes evanescent within the cluster size as in the bulk material. Plasma expansion from the gold cluster is also less due to the heavy mass of the gold ions. Therefore, the laser interaction process and the process of X-ray emission from the gold cluster could be similar to that of bulk material. Here each cluster behaves as a source of X rays. The number of gold clusters which are responsible for X-ray emission within the laser irradiated area being $\sim 2.6 \times 10^9$ /cc, X-ray intensity from the gold clustered target is lower than the bulk gold target.

There are various applications of clusters depending upon cluster size and laser parameters. Cluster study may open a new branch for the study of matter. Current advanced technologies require small and high speed microelectronic devices for improved processing and clusters may be advan-

tageous. Cluster studies may contribute to thin film manufacturing, interphase physics, combustion process, plasma fuel injection, atmospheric and astrophysical processes, aerosols and smoke, crystal growth, gas phase ion chemistry, catalysis, microelectronics, and photography (Mark, 1987) as a source of energetic ion/electron beam, hard X rays, nuclear fusion, higher harmonic generation, and so forth as discussed earlier.

3. ULTRA INTENSE LASER-CLUSTER INTERACTION AND ITS APPLICATION TO FAST IGNITION

A simple way to generate clusters is by using gas jets. When such clusters are exposed to intense laser fields multi-ionized atoms are formed in the cluster and its equilibrium is disturbed. The excess energy will fragment the cluster and appears as kinetic energy of the cluster constituents (Last *et al.*, 1997). The total charge of the ionized cluster is distributed among all cluster atoms and is assumed to be on the surface of the cluster. The total pressure on such a cluster has been calculated (Ditmire *et al.*, 1996) as $P = P_e + P_c$ where P_e is thermal pressure = NKT_e and P_c is Coulomb pressure = $q^2 e^2/8\pi r^4$ (r is radius of the cluster). Thus Coulomb pressure becomes more dominant for smaller clusters. For large values of r , both the pressures are important due to their dependence on r^{-3} and r^{-4} , respectively. Coulomb explosion of clusters originates from the charge buildup in the system because of the electron losses. Due to the repulsive Coulomb force, ions drift from their original position of center of mass. The time required for an ion to move twice the interatomic distance $d = 2R_0$ (where R_0 is the initial interatomic distance), has been discussed by Last *et al.* (1997) and it is called Coulomb explosion time τ_c . It is one of the ultra fast processes of ion motion and is of the order of $\sim 10^{-15}$. Thus the separation of ions in a cluster due to Coulomb force occurs in a femtosecond duration, which means kinetic energy of the exploding ions can be harnessed on a femtosecond time scale. To create a larger electrostatic field, it is necessary that the electrons from the cluster surface should be ripped off on a time scale shorter than the disassembly time of the cluster. Since we are dealing with a process of Coulomb explosion, cluster disassembly time can be taken as cluster explosion time.

Generation of energetic particles with energies exceeding megaelectronvolts due to cluster explosion as a result of laser cluster interaction has been reported by several authors (Ditmire *et al.*, 1997, 1998; Lezius *et al.*, 1998; Eloy *et al.*, 1999). Here we propose the possibility of harnessing the kinetic energy of the ions and electrons to heat a small volume of precompressed DT fuel to ignition conditions. This proposal is similar to fast ignition and we refer to it as cluster-induced ignition (CII). This is also a two-phase process. In the first phase, DT fuel is compressed due to ablative implosion induced by a set of high power laser beams irradiated symmetrically on the DT filled pellet surface as in

the conventional direct-drive scheme. In the second phase, when DT fuel is approaching an optimum compression, clusters are generated by gas jet in the vicinity of the edge of the compressing fuel and an ultra intense laser beam with intensity $I \sim 10^{18-20}$ W/cm² interacts with the clusters such that when DT fuel attains its maximum compression, the energetic ions and electrons are generated due to cluster explosion. All these operations need to be time synchronized on a few tens of femtoseconds time scale. In the first approximation, we assume a complete conversion of kinetic energy of the energetic particles into thermal energy of the compressed DT fuel. If the fuel has to be heated to 10 KeV in the ignition region, the required energy to be supplied is ≈ 10 KJ. We can estimate the required number of energetic particles of a given energy. A suitable irradiation of the required number of clusters in a given volume by ultra intense laser beams is necessary to deliver the energetic particles simultaneously to a part of the precompressed DT fuel.

This concept is drawn on the practical merits of direct drive, fast ignition, and cluster explosion. Further study is necessary to harness the benefits of this concept. Details of the work will be published elsewhere.

4. CONCLUSION

Clusters offer an interesting and important behavior. At moderate laser intensities $I \sim 10^{12}$ W/cm², small clusters with dimensions less than the laser wavelength show a significantly different behavior in X-ray emission spectra in the 5–22 nm range than the bulk material when irradiated with long pulse length laser (10 ns). Studies of clusters depict the evolution of material property as one moves from atomic state to bulk material. We believe there is a direct correlation between the size of the cluster and the wavelength and pulse duration of the incident laser radiation. Further study using various sizes of the cluster and laser parameters is necessary to understand the cluster properties and their evolution towards the bulk.

At ultra high intensity, laser cluster interaction shows many important processes due to Coulomb explosion and there is a possibility of harnessing the energy of the megaelectronvolts particles to heat a fraction of the precompressed DT fuel to ignition temperature similar to fast ignition.

Although substantial work has been done in laser cluster interaction, we believe much of cluster characteristic behavior is yet to be revealed. The cluster size (number of atoms per cluster), electron configuration combined with various laser parameters (like laser wavelength, pulse duration, and intensity) may offer an important study on cluster properties.

ACKNOWLEDGMENTS

The author sincerely acknowledges the financial support received from the TRILL Programme, ICTP, Trieste, and the University of Milano, Italy during the completion of this work.

REFERENCES

- BRECHIGNAC, C. *et al.* (1985). *Chem. Phys. Lett.* **120**, 559.
- DESAI, T. (1992). Ph.D. thesis, *Hydrodynamics of laser irradiated thin solid targets*. University of Bombay.
- DESAI, T. & PANT, H.C. (2000). *Laser Part. Beams* **18**, 119.
- DESAI, T. *et al.* (2000). *Proc. of 18 IAEA Fusion Energy Conf.* Sorrento, Italy.
- DITMIRE, T. *et al.* (1997). *Nature* **386**, 54.
- DITMIRE, T. *et al.* (1996). *Phys. Rev. A.* **53**, 3379.
- DITMIRE, T. *et al.* (1998). *Phys. Rev. A.* **57**, 369.
- ELOY, M. *et al.* (1999). *Proc. of IFSA meeting*, Bordeaux, 1003.
- GODWAL, B.K. *et al.* (1989). *J. Appl. Phys.* **65**(12), 4608.
- HAGENA, O.F. (1992). *Rev. Sci. Instrum.* **63**, 2374.
- HUTCHINSON, H. (1998). *Science* **280**, 693.
- JEFFREY, L. *et al.* (1992). *Phys. Rev. Lett.* **68**, 3535.
- KARDT, M.E. (1984). *Phys. rev. B* **29**, 1558.
- KNIGHT, W.D. *et al.* (1984). *Phys. Rev.* **52**, 2141.
- LAST, I. *et al.* (1997). *J. Chem. Phys.* **107**, 6685.
- LEZIUS, M. *et al.* (1998). *Phys. Rev. Lett.* **80**, 261.
- MARK, T.D. (1987). *Int. J. Mass Spectrom. Ion Process* **79**, 1.
- MATHEW, M.W. *et al.* (1986). *J. Phys. Chem.* **90**, 3152.
- MAX, C.E. (1982). *Physics of Laser Fusion*, Vol. 1, UCRL-53107. The Netherlands: North-Holland.
- MCPHERSON, A. *et al.* (1994). *Nature* **370**, 631.
- THOMSON, B.D. *et al.* (1994). *J. Phys. B, At. Mol. Opt. Phys.* **27**, 4391.
- TISCH, J. *et al.* (1997). *J. Phys. B, At. Mol. Opt. Phys.* **30**, L709.
- ZELDOVICH, YA & RAISER, YU. (1967). *Physics of Shock Waves and High Temperature Hydrodynamics Phenomena*, Vol. 1, 279. New York: Academic Press.