Materiality in Sound Art

ASBJØRN BLOKKUM FLØ

Norwegian Center for Technology in Music and the Arts (Notam), Sandakerveien 24D, Bygg F3, 0473 Oslo, Norway
Email: asbjorn@asbjornflo.net

This article investigates the recent resurgence of kinetic sound art in light of the relationship between art and material. It does this by studying the history of mechanical musical instruments and kinetic art, the role of immateriality in the history of Western art, and the renewed focus on materiality in the arts. Materiality is key to understanding the resurgence of kinetics in sound art. The first part of this article studies the historical narratives of materiality in sound art, while the second part investigates materiality in my own works as more contemporary examples. Here the text turns to exploration of the material and acoustic properties of metal rods and plates, and suggests that direct contact with sound-producing objects provides opportunities for new art forms where the morphology of sound can be developed in dialogue with the physical objects and the surrounding space. By examining the underlying acoustic principles of rods and plates, we get a deeper understanding of the relationship between mathematical models and the actual sounding objects. Using the acoustic model with basic input parameters enables us to explore the timbral possibilities of the sound objects. This allows us to shape the spectrum of acoustic sound objects with great attention to detail, and makes models from spectromorphology relevant during the construction of the objects. The physical production of sound objects becomes both spectral composition and shaping of spatial objects. This highlights the importance of knowledge of both materials and acoustic principles, and questions the traditional perception of sound art and music as immaterial art forms.

1. HISTORICAL NARRATIVES OF KINETIC SOUND ART

There are several historical narratives that lead to kinetic sound art but two of them are of particular interest: the history of mechanical musical instruments and the history of kinetic art. Descriptions of mechanical musical instruments stem from as far back as antiquity, an example is Ctesibius' (285–222 BC) water clock with accompanying automatons and mechanical sound sources (Pollard and Reid 2007). None of Ctesibius' written works has survived, but a well-documented piece of early music technology is the automatic flute player that was described in ninth-century Baghdad by the brothers Musa in the book *The Book of Knowledge of Ingenious Mechanical Devices* (Koetsier 2001).

Electricity was used with mechanical musical instruments early on. Jean-Baptiste Thillais Delaborde

built the electromechanical instrument *Clavecin Électrique* in 1759, and Pierre Stein built the world's first electromechanically controlled pipe organ for the world exhibition in Paris in 1855 (Hemsley 2005). Player pianos became popular in the latter half of the 1800s, and the solenoid-based player piano *Tel-Electric* (1907–17) is an early example of a programmable electromechanical instrument. This instrument is reminiscent of traditional player pianos, but the paper roll is replaced with a brass roll conducting electricity and the pneumatic mechanics are replaced with solenoids (Lehrman 2012).

The emergence of microcontrollers and magnetic storage media meant that player pianos reached a new level of precision in the early 1970s, and several patents and prototypes of computer-controlled electromechanical pianos were created (Englund 1971; Maillet 1974; Vincent 1975). The most prevalent of these early instruments was Superscope's *Pianocorder* (1977) (Fontana 1997). *Pianocorder* was technically a relatively open system, and composers such as Clarence Barlow, Alec Bernstein, Daniel Carney, Alistair Riddell, Richard Teitelbaum and Peter Zinovieff worked on algorithmic composition and computer control of the instrument from the early 1980s (Hopkin 1991). In 1980 the composer and artist Trimpin developed a similar electromechanical piano named the 'Vorsetzer' (Focke 2011; Leitman 2011).

Alistair Riddell continued developing software and hardware throughout the 1980s with his 'Meta-Action for the Grand Piano', which allowed individual control of the piano hammer and damper, as well as very high playback speed (Riddell 1990). During the mid-1980s, Daniel Carney and Alec Bernstein developed a fully computer controlled ensemble named the *Aesthetic Research Ensemble*, consisting of piano, percussion and stringed instruments (Hopkin 1991). Groups such as the *Logos Foundation* (1989–)¹ (Maes, Raes and Rogers 2011) and *LEMUR* (2000–) (Singer, Feddersen, Redmon

¹The *Logos Foundation* started making electronic sound-generating devices in the 1960s, then made several electronically controlled acoustic sound sculptures in the 1970s and 1980s (Maes, Raes and Rogers 2011; Raes 2018). The *Autosax* (1989–2012) is the first instrument similar to the rest of the *Logos Robot Orchestra*, and is described by *Logos* as "one of the very first automated instruments we designed" (Raes 1991). Because of this, 1989 is set as the beginning of The *Logos Foundations* collection of computer controlled acoustic musical instruments.

and Bowen 2004) has continued this work and built large collections of computer-controlled acoustic musical instruments.

One could argue that kinetic visual art originates from the automatons of antiquity, with devices actuated by water, wind, weights and steam being used as tools, toys or instruments for demonstrating scientific principles. In contrast to these early devices, modern kinetic art developed as a result of artistic subject matters, and emerged during the first half of the 1900s with artists such as Vladimir Tatlin, Alexander Rodchenko and Alexander Calder. Calder showed interest in contemporary music throughout his career, and stayed in contact with composers such as Erik Satie, Edgard Varese, John Cage, Pierre Boulez and Earle Brown. The collaboration with Earle Brown is particularly interesting. In his composition *Calder piece* (1967), Brown used a kinetic sculpture built by Calder for the piece to control the way the musicians interpreted the score (Fichter 2015). Calder's sculpture becomes a kinetic, spatial and non-repeating musical structure. Kinetics and movements have their own poetry and formal language, and as Jean-Paul Sartre points out in his text about Calder (Sartre 1996), the kinetic sculptures are already musical even though they do not produce sound. They are musical in terms of their movements, and can be interpreted as scales and chords translated into kinetic energy.

All production of sound depends on kinetic energy, whether the sound source is a loudspeaker or a traditional musical instrument. It is therefore no coincidence that sound artists soon saw the potential of kinetic art. An early example of kinetic sound art is the sculptures of the Swiss artist Jean Tinguely. In his *Méta-mécanique sonore* (1955), small hammers activated by the audience hit glasses, bottles and tin cans. Another early example of kinetic sound art is the work of American furniture designer, sculptor and sound artist Harry Bertoia. Bertoia was already working with wires and rods in his furniture and sculptures when he became significantly more interested in the sound of the rods around 1960. He became curious about the combined sound of several rods, and this led him to a systematic, experimental period. Although experimentation with sound within the arts was done throughout the entire twentieth century, Harry Bertoia's kinetic sound sculptures are distinguished from many works of his contemporaries through their finely detailed and rich timbres. His knowledge of the materials and determination to experiment, combined with daily practical work with the sounding materials, resulted in sculptures which have the sonic depth of highly developed musical instruments such as gongs or church bells. This places his work in an intermediate position between sculpture and music (Flø 2017).

The use of electricity to add energy to sculptures started early on, and one example is Naum Gabo's *Kinetic Construction (Standing Wave)* (1919–20),

where an electric motor initiates vibrations in a steel rod to transform the simple rod into a three-dimensional kinetic sculpture. Kinetic sound art also used electricity at an early stage, and one example is the work of American avant-garde musician Joe Jones. Jones was affiliated with Fluxus, and began to create electromechanical sound objects in 1961 (Shin 1992). One of his works is the *Mechanical Violin* (c.1964), where an electric motor with a rubber band continuously hits a violin. This object was part of the *Mechanical Flux Orchestra*, a group of automated instruments made by Joe Jones in the 1960s along with Fluxus artist George Maciunas. Of the artistic avant-garde movements of the twentieth century, Fluxus was among the most musical. At the heart of the movement were composers such as La Monte Young and Nam June Paik, and ideas about music and sound played an important role in the theoretical works of Fluxus. The found objects and experimental attitude to sound of the *Mechanical Flux Orchestra* opened up the definition of what music and art could be, thus the *Mechanical Flux Orchestra* represents the very essence of Fluxus.

2. CONCEPTUALIZING PHYSICAL SOUND OBJECTS

Alvin Lucier's *Music for Solo Performer* (1965) is another early example of conceptual works with electronically controlled acoustic sound objects. In this work, electrodes that recognise alpha brain waves are attached to the performer, activating multiple loudspeaker drivers. The loudspeaker drivers trigger a group of percussion instruments. This is done by playing directly on the instruments with objects attached to the loudspeaker drivers, or by activating the percussion instruments with sound. This practice of examining a dataset by mapping it to acoustic sound objects is found across several works of kinetic sound art. For example, in 1983, composer Peter Zinovieff used a filter bank to make transcripts of sounds that could be played in real time on a computer-controlled player piano. In performance, the computer analysed sounds from a radio and then played back the transcription of the analysis on the piano (Riddell 1989). A similar approach was also found in Peter Ablinger's series of works *Quadraturen III* (2004–14).

The exploration of spatial characteristics is central in several works of kinetic sound art. In Bosch and Simons' *Cantan un Huevo* (2000–01) a large number of glass bottles and containers mounted on the skeletons of spring mattresses is distributed across the space. The spring mattresses are excited by motors, and create oscillating vibrational patterns that are transmitted to the sound objects. The location of the different objects in the exhibition space is an integral part of the work,

which sounds different in every location in the space. The principle of similar sound objects distributed evenly across space can also be found in Gordon Monahan's installation *Resonant Platinum Records* (2012), where 12 aluminium plates are hung from piano strings attached to the ceiling of the exhibition space. A collection of sound files was produced to explore the resonant characteristics of the piano strings and plates, and transducers transmit the vibrations from the sound files through the wires to the plates. The large number of plates enables the movement of sound throughout the space. The sound objects are shaped with the space in mind, thus engaging in a dialogue with the acoustics and materiality of the space.

3. THE RESURGENCE OF KINETIC SOUND ART

Early mechanical musical instruments and sound automatons can to some extent be described as attempts to store music and sound. After the invention of sound recording in the second half of the 1800s, the mechanical musical instruments continued to increase in popularity, perhaps because of the limited sound quality of early sound recording. Even with the significant improvements in sound recording that became available after World War II, several composers continued to use mechanical musical instruments, perhaps because the unique compositional and technical possibilities of the mechanical musical instruments such as player pianos enabled musical and technical concepts that could not be realised with musicians and traditional notation. The interest in mechanical musical instruments remained throughout the 1970s and 1980s with computer-controlled acoustic ensembles such as the Aesthetic Research Ensemble (Hopkin 1991), and can partly be explained by the limited timbres of early electronic sound sources.

Today's electronic music tools do not have the same limitations as in the 1970s and 1980s, but in spite of this the interest in kinetic sound objects has had a strong resurgence as can be seen in the interest in works of artists such as Pe Lang and Zimoun as well as in viral videos of mechanical musical instruments such as the *Marble Machine* by Swedish band Wintergatan with more than 75 million views (Molin 2016). Technology and technical information is readily available, reducing the threshold for appropriation, and easy access to advanced software, electronics and mechanics as well as the exchange of knowledge on the Internet makes the production of kinetic sound objects far less complicated than it was just a few years ago. It is now relatively easy to build complex sound objects with software, electronics and mechanics, and the engineering difficulties that pioneers of kinetic sound art experienced have been greatly reduced. Information is

shared online, and conferences such as the International Computer Music Conference (ICMC) and New Interfaces for Musical Expression (NIME) are popular arenas for exchange of information and development of competence.

4. MATERIALITY

Although the production of kinetic sound objects is easier than it was a few years ago, we must look beyond aspects of sound quality and technical feasibility to get a deeper understanding of where this recent increased interest comes from. The same increased interest for physical objects and tactility can be noted in the expanding use of vinyl records and analogue modular synthesisers, and in the growth of the maker movement. Furthermore, the same tendency can be observed in the arts, with renewed interest in the art object and in the materiality of art.

In Monika Wagner's text 'Material' (Wagner 2001), the author explains how the apparent immateriality of music originally placed music over the fine arts in the traditional hierarchy of art. Before the fine arts were freed from the *artes mechanicae* in the Renaissance, they were linked to the guilds that worked with physical materials. Literature and music on the other hand, were linked to the superior *artes liberales*. Since they did not depend on physical material to be realised, they emerged as ideal, intellectual expressions of an idea. The senses of hearing and seeing were ranked highest because they seemed to be able to sense the immaterial, and thus came closest to the knowledge of God, while touch and physical materials were ranked lower. Music and poetry ranked highest, while fine art expressed through everyday physical materials such as oil, wood, stone and metal was ranked lower. The physical material belonged to everyday life and only through the artistic process could it transcend its material value. Art forms were ranked according to their dependence on the physical material well into the nineteenth century.

This view is still present. As Petra Lange-Berndt writes in her introduction to the anthology *Materiality* (Lange-Berndt 2015), getting involved with the materials of fine art is still regarded as the antithesis of intellectuality. The most studied works in contemporary art are, unsurprisingly, the works that are closest to writers. That is, language-based works, documentary works or works that illustrate philosophical theories. These theoretical works follow a philosophical tradition that prefers form above matter and the spiritual above the bodily, and show little interest in the role of the materials of art.

4.1. Art, materiality and technology

We also find the same views on materiality and immateriality in the discussions regarding art and

technology. As Wagner points out, François Lyotard's 1985 Paris exhibition *Les Immatériaux* was central to the modern discourse on art, materiality and technology. The exhibition examined how modern information technology changed our relationship with materiality, and contained not only objects but also data-generated texts and images. The material was historically seen as the base and counterpart to artistic creativity, which had to be transcended or transformed by art. But in this exhibition the algorithms got the same aura that once was reserved for the artist's work, transforming physical materials into a higher sphere. This was seen as a confirmation that the physical materials of the past were replaced with the intangible images and text of information technology (Wagner 2001). The various materials associated with the production of sound, text and image have been replaced with the computers speaker and display, and appear as temporary signs. Because the digital medium cannot be grasped in a haptic sense, or as an object for tactile differentiation, it is tempting to think of it as immaterial much in the same way we once looked at music and the musical symbols in the form of musical notation. As we will see later, working with sound can be abstract when using mathematical approaches and acoustic principles, but at the same time these abstractions occur in direct dialogue with the physical material, which questions the idea of the immateriality of sound.

4.2. The resurgence of materiality

It may look as if the material has been dissolved by the seemingly immateriality in the new technologies. However, the renewed interest in materiality during recent years can be seen as a counter-reaction to this. This focus on materiality does not need to revolve around traditional materials, but can just as well explore the materiality of film, video, sound or even cultural materials. In her article "‘Truth’ and ‘Truth to Material’: Reflecting on the Sculptural Legacy of Henry Moore" (Hiller 2003), artist Susan Hiller describes her own work with materiality. She uses everyday phenomena, cultural materials and artefacts from everyday life such as postcards, books, bottles or furniture as a starting point for her own work, and relates this practice to her own background in anthropology and to the history of modernist art. But where the artists of early modernism used cultural objects from Africa, Oceania and the Americas as raw material for their works (and in this way linked modernism to colonialism), Hiller uses materials from her own society. The leading principle for her is 'truth to material'. The material is not considered 'raw' or 'natural' and should not be transformed into anything else. Instead, it can be put in series, combinations and collections, so that the cultural references are not hidden.

The formal aspect of Hiller's works is based on the essence of the material. Hiller is attracted to materials that have a lot to say, and she considers her process more like collaboration with the materials. By studying the cultural objects, she tries to uncover suppressed or repressed meanings, and places this exploration of what she describes as 'the unconscious of culture' somewhere between finding and creating. Art becomes an area where possible meaning is discovered in these collective, cultural materials, and this attitude towards the material differs significantly from the classical mindset where neutral materials are shaped through the artistic process and transcends its material value. With Hiller, the work is created in direct dialogue with the material.

5. DIALOGUES WITH THE MATERIALS OF SOUND

When working with sound, what corresponds to this dialogue with materiality? If sound is immaterial, what is the material of music and sound art? Traditionally, the material of music has been abstract structures presented in musical notation. This did change somewhat with the introduction of electronic music; when the composer could work directly with sound. However, working directly with the sound-producing objects brings the composer even closer to the material, whether it consists of acoustic sound objects, electromagnetic sources such as loudspeakers and transducers or hybrids of these. If we work directly with the sound-producing objects, we can directly influence how they appear in space, both as art objects and as acoustic emitters (Figure 1). These sound-producing objects may appear limited in comparison with the apparently unlimited possibilities of synthetic sound. As Denis Smalley writes in his introduction to *Spectromorphology: Explaining Sound-Shapes* (Smalley 1997); electroacoustic music is no longer limited to the sounding models of instruments and voices, but open to all sounds. However, a deeper understanding of the acoustic properties of sound-producing objects enables us to produce physical objects with sounds beyond the existing models of instrumental music, using many of the same affordances we find in electronic music.

Spectromorphology is not a compositional theory, but it can influence compositional methods by making the composer aware of sounding models that can later be addressed in his or her own artistic thinking. Likewise, it is advantageous to understand the mechanisms that create sound in order to better work in direct dialogue with the sound-producing materials. Computer-assisted acoustic analysis and re-synthesis is an important tool for building physical sound objects (Flø and Wilmers 2015a). Building physical sound objects is demanding regarding both labour and money, and it is advantageous



Figure 1. *Doppelgänger* consisted of several sound objects distributed throughout the exhibition space in Bergen Kunsthall. Photo: Thor Brødreskift.

to craft simulations of the timbres before starting to build the physical sound objects. These simulations can also be used as a tool for investigating the artistic possibilities of the kinetic sound objects.

5.1. Composing with physical objects

Dialogues with the materials of sound were central to the work on my installation *Doppelgänger* (2014). Similar to the works of Lucier, Zinovieff and Ablinger, I wanted to investigate a dataset extracted from sound by mapping it to acoustic sound objects. In *Doppelgänger*, the sounding objects were three-metre tall rectangular metal plates. Microphones were placed in the cafe next to the gallery space, the sound from the microphones was analysed and then mapped to the acoustic sound objects. The sound of the social space in the cafe next to the exhibition space was loaded with information, and by re-positioning the sound I wanted to uncover hidden meanings, in a process similar to what Hiller described as being between finding and creating. The sounds are used in a way similar to working with found objects, where the artist creates art from materials that normally have a non-art function. The process includes finding existing sounds with a cultural significance as well as creating new works with the same sounds, thus operating between finding and creating.

Just as with Hiller, this work was created in dialogue with the material. I started my work on the re-positioning of audio streams with the installation *Norway Remixed* in 2002 (Rudi 2003). However, where the

audio streams in *Norway Remixed* were transformed through signal processing of the sound itself, the sounds in *Doppelgänger* were transformed by mapping analysis data from the audio streams to acoustic sound objects. The transformation of material in *Doppelgänger* was not limited to what was picked up by the microphones. The installation consisted of several sound objects distributed throughout the space. As in the works of Monahan, Bosch and Simons, the objects were made with the exhibition space in mind, creating a dialogue between the installation and the materiality of the space.

Working on *Doppelgänger* made it apparent that there was an untapped artistic potential in the sounds of metal objects. In the installation *Vardøger* (2018–2019), the sound of metal is further examined, and the objects consist of resonant bronze rods coupled through circular metal plates. While *Doppelgänger* investigated the found structures of external sounds, *Vardøger* turns the focus inwards toward the materiality of the objects themselves.

According to Norwegian folklore, a *Vardøger* is a spirit predecessor who is linked to a person, and thus related to the *Doppelgänger* phenomenon. The experience of a *Vardøger* is often described as a premonition of a person before the person arrives, and the premonition often occurs in the form of sound. There is no scientific basis for this phenomenon, and it is often explained as pareidolia, the brain's ability to see patterns and structures that do not necessarily exist. Just as the brain is looking for patterns and structures in things that do not necessarily exist, looking for patterns and structures is also central to the concept of

the installation *Vardøger*. More specifically, I was interested in acoustic patterns and structures and how they relate to the physical material. The focus on the object's materiality, timbre, acoustic patterns and structures may seem abstract compared to the repositions of sound and meaning in the installations *Norway Remixed* and *Doppelgänger*, but this new level of abstraction also means approaching many of the central topics of musical composition. The difference is that the composition in this case takes place through the formation of materials and physical objects in space. To get a deeper understanding of composing with physical objects, we must look into the acoustic principles behind these objects.

The physical basis for *Vardøger* is vertical, round bronze rods mounted on a freely suspended horizontal circular steel plate. The rods are excited by electromagnetically controlled bowing mechanisms as well as electromagnetically controlled hammers similar to the ones used in *Doppelgänger* (Figure 2; Flø and Wilmers 2015b). The timbre is further coloured by the steel plate. In order to better shape the sounding material in a satisfactory way, it is important to know and understand the basic acoustic principles behind rods and plates. The dialogue with the materiality of the sound objects is twofold: we are working with physical objects and their appearance in space, and at the same time with acoustic principles and how they could be useful for realisation of the artistic idea.

5.2. The properties of inharmonic spectra

When a round rod is excited by a hammer or a bow, it resonates with a certain set of frequencies. The fundamental frequency is determined by the length and diameter of the rod, the density and elasticity of the material, and the way the rod is mounted. The resonant frequencies are calculated by multiplying the fundamental frequency with a number series that only depends on the way the bar is mounted (Figure 3; Fletcher and Rossing 2010: 64). The fundamental frequency (and thus all resonance frequencies) is proportional to the inverse of the length squared $\frac{1}{L^2}$. When comparing it with a violin string where the fundamental frequency is proportional to the inverse of the length $\frac{1}{L}$, we understand why the distance between higher resonances and the fundamental frequency is increasing more rapidly than is the case with the violin string. As Smalley has shown, such inharmonic spectra may be perceived as ambiguous since they exist between noise, timbre, pitch and intervallic combinations. By adjusting the bar dimensions and alloys we can decide where we want to place the sound within this spectral field. The hands-on work with the physical material is at one and the same time spectral composition and shaping of a spatial object.

The rods are mounted on a circular steel plate. This plate connects the rods, and like the rods, the plate has a set of inharmonic resonances. Thus, the plate both

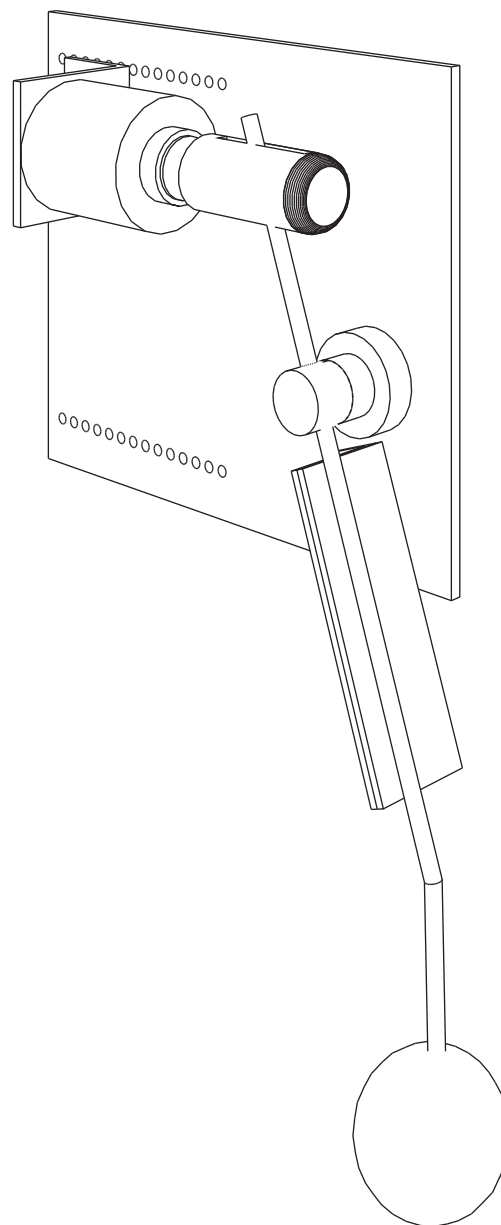

Figure 2. The electromagnetically controlled hammer used in *Doppelgänger*.

prolongs the reverberation of the rods and adds a separate set of resonances. The fundamental frequency of the plate is determined by the way it is mounted, and by its thickness and diameter as well as the density of the material, elasticity and Poisson's ratio (which describes how much the material increases in width when pushed together) (Leissa 1969: 1).

The remaining resonance frequencies of the plate are obtained by multiplying the basic frequency with a number sequence identical for all round free-hanging plates. Common to these series of numbers is that they result from differential equations that describe the forces that act on the object when it is deformed, and how the mass is distributed. In a violin string it is

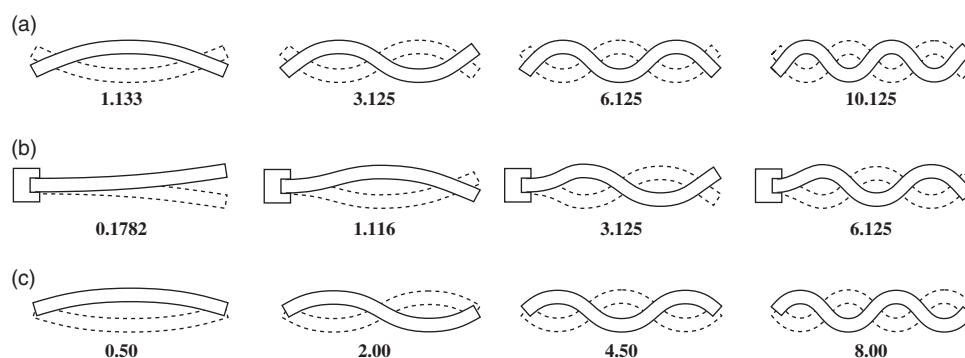

Figure 3. The resonant frequencies of a bar depends on the way the bar is mounted. Bending vibrations of (a) bar with free ends, (b) bar with one clamped end and (c) bar with two supported ends. The numbers are relative frequencies (Fletcher and Rossing 2010: 64).

simple, in a drum skin a little more complicated, and analytical solutions exist for both these examples. With a certain thickness of material, such as in a metal plate, the solution is more complicated since the deformation of the material is important. In most cases, no analytical solution exists, only numerical approximations or measurements. Nevertheless, the results of either calculation or measurement may in some cases approach a row of numbers that looks simple, and can in this case lead to a simplified mathematical model. For circular plates, the number of resonance frequencies approaches asymptotically $(m + 2n)^2 * const.$ – a series that is proportional to $(m + 2n)^2$. Once again, the artistic work with the sound objects is twofold. On the one hand it is highly abstract, and the mathematical approach to acoustics is close to the idealised image of music and sound as an immaterial art form. On the other hand, this is a direct work on physical objects, where all the physical adjustments affect each other, both internally in the object and externally in interaction with the space, resulting in interesting surprises and artistic discoveries. Metal objects and their surrounding spaces are sources of highly complex timbres, and simplified mathematical models serve just as a starting point. Only through direct experimentation on the sound objects can their sounding potential be fully uncovered.

5.3. Metallurgy and spectromorphology

As we have seen earlier, the starting point for *Vardoger* is a horizontal circular steel plate with mounted vertical bronze rods. The sounding properties of steel and bronze are defined by density, elasticity and Poisson's ratio. These parameters influence the location of the partials in the spectrum. By varying these parameters we can easily simulate different alloys such as steel, aluminium or bronze, or even examine the differences between various bronze alloys. This allows the artist to perform detailed investigations of the differences in sound between various alloys. Working with the relationship between timbre and alloys leads us to further examine the field of metallurgy.

The history of metals is parallel to the development of civilisation and technology. This connects metallurgy to the production of weapons, and makes the metallurgical history of sound and war closely intertwined, as is the case with many audio technologies. The bell bronze alloy was originally developed for its acoustic properties but was later used in the production of cannons for early Spanish, Portuguese and Javanese artillery.

On the other hand, metallurgical knowledge is the basis for developing sounding metal objects, with distinctive qualities that we recognise in cultural objects. As mentioned above, the sounding properties of metal alloys are defined by density, elasticity and Poisson's ratio. Combining the acoustic models of alloys with the models for rods and plates, allows us to investigate different timbres from various alloys, shapes and sizes. With this method of working we combine knowledge about metallurgy, acoustics, spectromorphology and composition. This direct work on the constituents of metal connects us with the material history of metallurgy, and enables us to explore different spectromorphological shapes and artistic ideas, given that different alloys end up providing very different results.

The timbre of the plates and the rods are shaped by their dimensions. In *Vardoger*, the plates and rods have different lengths, diameters and thicknesses. Increases in thickness cause linear increase in frequencies. Doubling the thickness of a plate or rod results in a spectrum one octave above the original. The diameters of the plates in *Vardoger* vary between 50 and 150 cm, and the lengths of the rods vary between 10 and 300 cm. Thicknesses between 1 and 8 mm often result in a very low fundamental. As an example, a steel rod with a length of 3 m and a thickness of 3 mm will produce a fundamental of about 1.5 Hz and will not produce any partials within the limits of human hearing until reaching the sixth partial. The plates behave in the same manner. The sound we hear from the plates and the rods will therefore often consist of higher partials in the spectrum. By varying the length, diameter and thickness of the plates and rods, we can move the spectrum up and down in the frequency

range, thus creating varied and complex sounds. This relates to what in spectromorphology is called *spectral space and density*, density being the amount of spectromorphological information that is contained within a spectral space. With long, thin objects in which the fundamental is well below the hearing threshold, the audible partials will be placed close together in clusters, thus creating compressed spectral spaces. Thick short objects will have a fundamental above the hearing threshold, and thus moving the partials higher up in the spectrum, resulting in less compressed spectral spaces.

5.4. Weighting the partials

The sound objects in *Vardøger* are excited in two ways: with computer-controlled rotating objects that act as bows, and with electromagnetically controlled hammers. I studied the history of mechanical musical instruments while making these mechanisms, particularly the history of player pianos starting in the latter half of the 1800s and culminating with the highly sophisticated computer-controlled electromechanical pianos of 1970s and 1980s.

Through these mechanisms, we can explore combinations of spectromorphological archetypes such as *attack*, *attack-decay* and *graduated continuant*. Since this is computer-controlled and distributed in space, it also allows you to move sound in space. What objects we use to hit the rods impacts the timbre. The timbre is shaped by the mass, shape and stiffness of the object. A large, heavy and soft object highlights low frequencies, and a small light and hard object draws attention to high frequencies. The selection of objects used to hit the rod creates large variations in timbre, while we in fact always hear the same set of partials with different weighting of the amplitudes. By selecting which object is used to hit the rod, we can highlight various parts of the spectrum based on artistic preferences.

Although the sound of an object being excited by a bow is completely different from the sound of the same object when excited by a hammer, we still hear the same set of partials. In the same way that we get different sounds with different hammers through weighting of the amplitudes of the partials, we can use a bow instead of a hammer to get new sounds based on the same set of partials. Selecting the dominant partial can be controlled by varying where the bow excites the rod as well as the velocity and pressure of the bow. In this way we can vary what is practically perceived as the fundamental of the bowed sound.

5.5. Energy transfers, morphology and space

Although we have models for calculating resonance frequencies and how different excitation objects shape the sound, these will appear as simplifications when

held up against the actual sound. A simple frequency analysis will show that the partials from a single rod or plate are weighted in complex ways, changing over time so that the amplitudes and durations of individual partials differ significantly from the other partials coming from the same rod or plate.

This can be partly explained by non-linearity and energy transfers between oscillators, where energy further down in the set of partials is transferred to frequencies higher up. This causes some partials to keep resonating longer than others and is an important aspect of sound from metal objects. We can model this mathematically by adding a triangle wave of the same frequency to each sine, (that is, we use the 3rd, 5th, 7th, etc. harmonics), and convolving it with an impulse response of the resonant frequencies. The result is again an impulse response, and can thus be used as a linear system. In this way we can create a linear system that mimics non-linear effects, and even though this is an imprecise system, it still gives us a good idea of what to expect from the sound of the physical object. This is also interesting in relation to spectromorphology, since spectromorphology describes both the spectrum and how it is shaped over time (-morphology). The morphology of the partials as a result of energy transmissions internally in an acoustic object is not something that can be easily controlled, but we can shape how the different parts of the final sound object transmit energy between each other, and in this way work directly with the morphology of the spectrum.

With models for resonant frequencies, excitation objects and energy transfers of partials, we have good tools for understanding the timbre of the various individual parts. A new layer of complexity emerges when we connect these parts by assembling several bronze rods on a steel plate. The different parts resonate in sympathy with each other, and this is a phenomenon known from traditional musical instruments with sympathetic strings such as the Norwegian Hardanger fiddle, where four to five resonance strings resonate with their fundamental or harmonic partials when the other strings on the fiddle are played. This is similar to what is happening in Alvin Lucier's composition *I Am Sitting in a Room* (1970), where a sound recording of a voice is recorded repeatedly through a resonant space until what is left are only the frequencies common for the voice and the resonances of the space (Lucier 2011). The difference is that the metal plate that constitutes the space in our model is not given but can be shaped in interaction with the resonant rods. We get additional energy transfer between partials, so that energy from a partial in one rod is transferred to partials in another rod or plate, causing certain partials to be highlighted or muted. The energy can also travel back and forth between these oscillators without finding an equilibrium, and with complex couplings as in *Vardøger*, energy will continuously move back and forth. This can be controlled to a certain extent by altering the dimensions and alloys of the various rods and plates, but the unpredictable

and complex relationship between the partials is also a characteristic part of the installation's timbre.

In addition to the resonating spaces created inside the sound objects, the placement of objects in the exhibition space will affect the timbre. As Lucier points out in his article about the propagation of sound in space (Lucier 2011), sound sources have specific spatial characters. Short wavelengths are directional while long wavelengths are spread out in space. Each individual space has its own set of characteristics with absorption, reflection, attenuation and other structurally related phenomena. If we use the features of the space as an active material and shape the sound objects in dialogue with the space, we can enter an interesting artistic dialogue between the acoustics of the objects and the materiality of space.

6. CONCLUSION

Kinetic sound art occupies an interesting position between spatial object and musical instrument, and has its genealogy from both mechanical musical instruments and kinetic art. Although sound art and music are traditionally perceived of as immaterial art forms, the role of materiality is key to understanding the resurgence of kinetic sound art, and what attracts artists to the medium.

Through studies of the acoustic qualities of the sounding objects, the relationship between physical objects and mathematical models becomes accessible, and the acoustic models for the sound objects in the installation *Vardøger* show us that with a set of basic input parameters we can create a wide variety of timbres. With these parameters we can shape the sound in artistically interesting ways when building acoustic sound objects, and this gives the sound models from spectromorphology a new relevance beyond electroacoustic music. The hands-on work with the physical material becomes both spectral composition and shaping of a spatial object.

Our acoustic model for metal objects represents a simplification of the acoustic reality, but precise enough for the artist to gain a better understanding of sound as well as serving as a basis for exploring ideas before translating them into physical sound-producing objects. Working with the materiality of sound questions the historical understanding of sound art and music as immaterial art forms, and the direct work with the sound-producing objects provide opportunities for new forms of art in dialogue with both space and the physical objects.

Acknowledgements

The author would like to thank Hans Wilmers for creating the tools for acoustic analysis and resynthesis used in this work and for helpful comments on this paper.

REFERENCES

- Englund, E. J. 1971. Method and Apparatus for Recreating a Musical Performance. US Patent 3,604,299A filed 22 April 1970, and issued 14 September 1971.
- Fichter, T. 2015. Earle Brown's Calder Piece and Alexander Calder's Chef d'orchestre. In A. Borchardt-Hume (ed.) *Alexander Calder: Performing Sculpture*. London: Tate Publishing.
- Fletcher, N. H. and Rossing, T. D. 2010. *The Physics of Musical Instruments*, 2nd edn. New York: Springer.
- Flø, A. B. 2017. Harry Bertoia and Norway. *Ballade*, 13 March. www.ballade.no/sak/harry-bertoia-and-norway/ (accessed 15 March 2018).
- Flø, A. B. and Wilmers, H. 2015a. The Intrinsic Value of Timbre in Doppelgänger. *Proceedings of the 2015 International Computer Music Conference*. Denton/San Francisco: ICMA.
- Flø, A. B. and Wilmers, H. 2015b. Doppelgänger: A Solenoid-Based Large-Scale Sound Installation. *Proceedings of the 2015 International Conference on New Interfaces for Musical Expression*. Baton Rouge: NIME.
- Focke, A. 2011. *Trimpin: Contraptions for Art and Sound*. Seattle: University of Washington Press.
- Fontana, M. A. 1997. Preservation and MIDI Translation of the Pianocorder Music Library. Master's thesis, Ohio State University.
- Hemsley, J. D. C. 2005. *Henry Bryceson (1832–1909) Organ-Builder and Early Work in the Application of Electricity to Organ actions*. PhD thesis, Cardiff University.
- Hiller, S. 2003. 'Truth' and 'Truth to Material': Reflecting on the Sculptural Legacy of Henry Moore. In J. Beckett and F. Russell (eds.) *Henry Moore: Critical Essays*. Aldershot: Ashgate.
- Hopkin, B. 1991. Computer Control for Acoustic Instruments. *Experimental Musical Instruments Journal* 7(1): 1, 8–11.
- Koetsier, T. 2001. On the Prehistory of Programmable Machines: Musical Automata, Looms, Calculators. *Mechanism and Machine Theory* 36: 589–603.
- Lange-Berndt, P. 2015. Introduction. In P. Lange-Berndt (ed.) *Documents of Contemporary Art: Material*. Cambridge, MA: MIT Press, and London: Whitechapel Gallery.
- Lehrman, P. 2012. Multiple Pianolas in Antheil's *Ballet Mécanique*. *Proceedings of the 2012 International Conference on New Interfaces for Musical Expression*. Ann Arbor: NIME.
- Leissa, A. W. 1969. *Vibration of Plates*. Washington, DC: Office of Technology Utilization, NASA.
- Leitman, S. 2011. Trimpin: An Interview. *Computer Music Journal* 35(4): 12–27.
- Lucier, A. C. 2011. Careful Listening is More Important than Making Sounds Happen: The Propagation of Sound in Space (1979). In C. Kelly (ed.) *Documents of Contemporary Art: Sound*. Cambridge, MA: MIT Press, and London: Whitechapel Gallery.
- Maes, L., Raes, G.-W. and Rogers, T. 2011. The Man and Machine Robot Orchestra at Logos. *Computer Music Journal* 35(4): 28–48.
- Maillet, J. 1974. Tape Activated Piano and Organ Player. US Patent 3,789,719A filed 28 August 1972, and issued 5 February 1974.
- Pollard, J. and Reid, H. 2007. *The Rise and Fall of Alexandria: Birthplace of the Modern World*. London: Penguin.

- Raes, G.-W. 1991. Autosax, an Automated Microtonal C-Melody Saxophone. http://logosfoundation.org/instrum_gwr/autosax.html (accessed 12 May 2018).
- Raes, G.-W. 2018. Catalogue of Instruments and Automats. <http://logosfoundation.org/godfried/instrum-god.html> (accessed 12 May 2018).
- Riddell, A. 1989. *A Perspective on the Acoustic Piano as a Performance Medium Under Machine Control*. Master's thesis, La Trobe University.
- Riddell, A. 1990. A Meta-Action for the Grand Piano. *Proceedings of the 1990 International Computer Music Conference*. Glasgow/San Francisco: ICMA.
- Rudi, J. 2003. *Norge – et lydrike, Norway Remixed: A Sound Installation*. *Organised Sound* 8(2): 151–5.
- Sartre, J.-P. 1996. *Calder's mobile (1949)*. In *Calder*. Stockholm: Moderna Museet.
- Shin, N. 1992. Fluxing Music: Interview with Joe Jones. *XEBEC SoundCulture Membership Magazine*.
- Singer, E., Feddersen, J., Redmon, C. and Bowen, B. 2004. Lemur's Musical Robots. *Proceedings of the 2004 International Conference on New Interfaces for Musical Expression*. Hamamatsu: NIME.
- Smalley, D. 1997. Spectromorphology: Explaining Sound-Shapes. *Organised Sound* 2(2) 107–26.
- Vincent, R. A. 1975. Electronic Player Piano with Record and Playback Feature. U.S. Patent 3,905,267A filed 4 February 1974, and issued 16 September 1975.
- Wagner, M. 2001. Material. In K. Barck (ed.) *Ästhetische Grundbegriffe, Historisches Wörterbuch in 7 bänden, vol 3*. Stuttgart: J. B. Metzler.

VIDEOGRAPHY

- Molin, M. 2016. *Wintergatan – Marble Machine (Music Instrument using 2000 Marbles)*. www.youtube.com/watch?v=IvUU8joBb1Q (accessed 12 May 2018).