



Research Article

The association between symptom burden and processing speed and executive functioning at 4 and 12 weeks following pediatric concussion

Veronik Sicard¹ , Andrée-Anne Ledoux^{1,2}, Ken Tang³, Keith Owen Yeates^{4,5,6}, Brian L. Brooks^{4,6,7,8,9}, Peter Anderson^{1,10}, Michelle Keightley^{11,12}, Naddley Desire¹³, Miriam H. Beauchamp^{14,15}, Roger Zemek^{1,16,17} and for the Pediatric Emergency Research Canada (PERC) 5P Neuropsych team

¹Children's Hospital of Eastern Ontario Research Institute, Ottawa, ON, Canada, ²Department of Cellular and Molecular Medicine, University of Ottawa, Ottawa, ON, Canada, ³Independent Statistical Consultant, Richmond, BC, Canada, ⁴Department of Psychology, University of Calgary, Calgary, AB, Canada, ⁵Alberta Children's Hospital Research Institute, Calgary, AB, Canada, ⁶Hotchkiss Brain Institute, University of Calgary, Calgary, AB, Canada, ⁷Department of Clinical Neurosciences, University of Calgary, Calgary, AB, Canada, ⁸Neurosciences Program, Alberta Children's Hospital, Calgary, AB, Canada, ⁹Department of Pediatrics, University of Calgary, Calgary, AB, Canada, ¹⁰Mental Health Neuropsychology Program, Children's Hospital of Eastern Ontario, Ottawa, ON, Canada, ¹¹Bloorview Research Institute, Holland Bloorview Kids Rehabilitation Hospital, Toronto, ON, Canada, ¹²Departments of Occupational Science and Occupational Therapy and Rehabilitation Sciences Institute, University of Toronto, Toronto, ON, Canada, ¹³Department of Psychology, The Hospital for Sick Children, Toronto, ON, Canada, ¹⁴Department of Psychology, University of Montreal, Montreal, QC, Canada, ¹⁵Ste-Justine Hospital Research Center, Montreal, QC, Canada, ¹⁶Department of Pediatrics, University of Ottawa, Ottawa, ON, Canada and ¹⁷Department of Emergency Medicine, University of Ottawa, Ottawa, ON, Canada

Abstract

Objectives: Symptoms and cognition are both utilized as indicators of recovery following pediatric concussion, yet their interrelationship is not well understood. This study aimed to investigate: 1) the association of post-concussion symptom burden and cognitive outcomes (processing speed and executive functioning [EF]) at 4 and 12 weeks after pediatric concussion, and 2) the moderating effect of sex on this association. **Methods:** This prospective, multicenter cohort study included participants aged 5.00–17.99 years with acute concussion presenting to four Emergency Departments of the Pediatric Emergency Research Canada network. Five processing speed and EF tasks and the Post-Concussion Symptom Inventory (PCSI; symptom burden, defined as the difference between post-injury and retrospective [pre-injury] scores) were administered at 4 and 12 weeks post-concussion. Generalized least squares models were conducted with task performances as dependent variables and PCSI and PCSI*sex interaction as the main predictors, with important pre-injury demographic and injury characteristics as covariates. **Results:** 311 children (65.0% males; median age = 11.92 [IQR = 9.14–14.21 years]) were included in the analysis. After adjusting for covariates, higher symptom burden was associated with lower Backward Digit Span ($\chi^2 = 9.85, p = .043$) and Verbal Fluency scores ($\chi^2 = 10.48, p = .033$) across time points; these associations were not moderated by sex, $ps \geq .20$. Symptom burden was not associated with performance on the Coding, Continuous Performance Test, and Color-Word Interference scores, $ps \geq .17$. **Conclusions:** Higher symptom burden is associated with lower working memory and cognitive flexibility following pediatric concussion, yet these associations were not moderated by sex. Findings may inform concussion management by emphasizing the importance of multifaceted assessments of EF.

Keywords: Mild traumatic brain injury; cognitive functioning; neuropsychological assessment; post-concussion syndrome; youth; cognitive testing

(Received 4 August 2023; final revision 24 November 2023; accepted 2 January 2024; First Published online 26 January 2024)

Introduction

Concussion, a mild subtype of traumatic brain injury (McCrory, Feddermann-Demont, et al., 2017; McCrory, Meeuwisse, et al., 2017; Silverberg et al., 2023), is common in children and adolescents. Although most children and adolescents recover within 2 weeks of

injury (Ledoux et al., 2019), one-third will experience persisting symptoms after concussion lasting more than 1 month (Chadwick et al., 2022; Zemek et al., 2016). These symptoms can include ongoing physical and somatic complaints, mood disturbance, behavioral changes, and cognitive symptoms, which may be associated with impaired academic performance, school absenteeism, depressed

Corresponding author: Andrée-Anne Ledoux; Email: aledoux@cheo.on.ca
VS and AAL are co-first authors.

Cite this article: Sicard V., Ledoux A.-A., Tang K., Yeates K.O., Brooks B.L., Anderson P., Keightley M., Desire N., Beauchamp M.H., & Zemek R. for the Pediatric Emergency Research Canada (PERC) 5P Neuropsych team. (2024) The association between symptom burden and processing speed and executive functioning at 4 and 12 weeks following pediatric concussion. *Journal of the International Neuropsychological Society*, 30: 533–545, <https://doi.org/10.1017/S1355617724000043>

© The Author(s), 2024. Published by Cambridge University Press on behalf of International Neuropsychological Society. This is an Open Access article, distributed under the terms of the Creative Commons Attribution licence (<http://creativecommons.org/licenses/by/4.0/>), which permits unrestricted re-use, distribution and reproduction, provided the original article is properly cited.

mood, and lower quality of life (Howell et al., 2019; Ledoux et al., 2022; Novak et al., 2016; Russell et al., 2017, 2019). Cognitive symptoms such as difficulty concentrating and remembering, feeling like one is in a fog or slowed down, and confusion are often self-reported post-concussion (McCroory et al., 2013; Reed et al., 2021). These subjective experiences provide valuable insights into the individual's perception of their cognitive functioning and challenges. However, self-reporting alone may not provide a comprehensive understanding of the extent of cognitive changes after concussion. As such, objective evaluation of cognition through neuropsychological testing is often utilized as an indicator of recovery following pediatric concussion along with symptom ratings (Haider et al., 2018). The relation between self-reported symptoms and objective cognitive functioning is not well understood.

Processing speed refers to the ability to process information and complete cognitive tasks quickly and efficiently. While some studies have indicated alterations in processing speed in the days following concussion (Kontos et al., 2014) that tend to resolve by a few months post-injury (Hou et al., 2023; Robertson-Benta et al., 2023; Rohling et al., 2011), other studies have reported null findings across injury phases (Alsalaheen et al., 2021; Redlinger et al., 2022; Sicard et al., 2022; Sicard, Hergert, et al., 2021). Processing speed is closely linked to executive functioning (EF), which encompasses top-down cognitive processes responsible for planning, organizing, initiating, monitoring, and controlling goal-directed behavior. EF relies on efficient processing speed to analyze and integrate information in a timely manner. Accumulating evidence in pediatric and adult samples has suggested that EF is particularly susceptible to concussion, with lower performance on EF tasks in individuals within weeks to months of a concussion relative to individuals without concussion (Baillargeon et al., 2012; Chadwick et al., 2021; Halterman et al., 2006; Howell et al., 2013; Lax et al., 2015; Loher et al., 2014; Mayr et al., 2014; Moore et al., 2014, 2015, 2016, 2017, 2019; Ozen et al., 2013; Ozturk et al., 2021; Robertson-Benta et al., 2023; Sicard, Caron, et al., 2021; Sicard et al., 2018, 2019, 2020; Sicard, Harrison, et al., 2021). A recent meta-analysis indicated that athletes with a history of concussion (at least 3 months from their last concussion) perform more poorly on EF tasks when compared to controls with no history of concussion, although no such differences were observed for other cognitive domains (Redlinger et al., 2022).

To date, a limited number of studies have addressed the association between post-concussion symptom burden and cognitive functioning, especially in pediatric concussions. In children and adolescents with a concussion, neuropsychological outcomes were not solely attributable to premorbid factors but instead associated with a combination of premorbid factors and injury-related variables, including symptoms (Babcock et al., 2013; Beauchamp et al., 2018). More recently, symptom burden combined with an increased clinical risk score for persisting symptoms after concussion (Zemek et al., 2016), was found to be associated with poorer processing speed and attention within 11 days of injury, but not at 4 months (Sicard, Hergert, et al., 2021). A follow-up study showed significant group differences between symptomatic concussed adolescents and non-injured comparisons within 11 days of injury, but not at 4 months post-concussion, on an EF composite score, and no differences were observed for working memory at either time point (Robertson-Benta et al., 2023). Another study showed that symptom burden correlated with verbal learning recognition, verbal fluency, and mathematical fluency in adolescents, but not in children, within a month

of their concussion (Jones et al., 2023). In youth hockey players approximately 6 days post-concussion, greater missed errors on a nonverbal working memory task were associated with greater symptom burden (Green et al., 2018). In adults, university athletes with persisting symptoms after concussion showed lower cognitive performance on a computerized working memory task relative to their asymptomatic and healthy counterparts 3 weeks to 2 months post-injury (Sicard, Harrison, et al., 2021). Moreover, in university athletes with post-concussion symptoms, headache was a significant predictor of worse attention/EF composite scores within 2 weeks of their injury (Guty et al., 2021) and attention/processing speed impairment from 6 months to 3 years post-concussion (Guty & Arnett, 2018). However, another study of children and adolescents on average 34 months post-concussion did not observe correlations between headache symptoms and EF measures included in the CNS Vital Signs battery (i.e., reaction time, complex attention, cognitive flexibility; Kwan et al., 2020). Similarly, processing speed and working memory did not significantly predict group membership (children with persisting symptoms after concussion vs. comparison) when entered into a single model (Anzalone et al., 2022).

While these studies made important contributions to the concussion literature, their findings are limited by modest sample size (Anzalone et al., 2022; Green et al., 2018; Guty et al., 2021; Jones et al., 2023; Kwan et al., 2020; Sicard, Harrison, et al., 2021; Sicard, Hergert, et al., 2021), inclusion of transitional age youth or adult patients only (Guty et al., 2021; Guty & Arnett, 2018; Robertson-Benta et al., 2023; Sicard, Hergert, et al., 2021), inclusion of only sports-related concussions (Green et al., 2018; Guty et al., 2021; Guty & Arnett, 2018; Sicard, Harrison, et al., 2021), cross-sectional study designs (Anzalone et al., 2022; Guty et al., 2021; Guty & Arnett, 2018; Jones et al., 2023; Kwan et al., 2020; Robertson-Benta et al., 2023; Sicard, Harrison, et al., 2021), omission of specific processing speed measures (Jones et al., 2023; Sicard, Harrison, et al., 2021; Sicard, Hergert, et al., 2021), and restriction to a single EF construct (Green et al., 2018; Sicard, Harrison, et al., 2021; Sicard, Hergert, et al., 2021). Due to the limitations of existing studies, a critical knowledge gap remains regarding the association between post-concussion symptom burden and EF, following pediatric concussion.

Furthermore, these studies have not investigated the effect of sex on the interaction between symptoms and cognition. Previous research has suggested an elevated symptom burden, increased prevalence of persisting symptoms after concussion, and possibly lower cognitive functioning post-concussion in females relative to males (Alsalaheen et al., 2021; Broshek et al., 2005; Brown et al., 2015; Covassin et al., 2012, 2018; Hannah et al., 2021; Howell et al., 2018; Koerte et al., 2020; Ledoux et al., 2019; Merritt et al., 2019; Mollayeva et al., 2019; Sicard et al., 2018; Yeates et al., 2022; Zemek et al., 2016). Moreover, sex differences are observed in brain development in terms of myelination of axons, regional gray matter volumes, cortical thickness, and brain functioning (DeCasien et al., 2022; Giedd & Rapoport, 2010; Gur & Gur, 2016; Silk & Wood, 2011). Studies exploring the potential influence of sex on concussion outcomes and the relationship between symptoms and cognitive functioning are needed (Merritt et al., 2019).

The primary objective of this study was to investigate the association between symptom burden and cognition (processing speed and EF) at 4 and 12 weeks following a pediatric concussion. Higher symptom burden was hypothesized to be associated with lower processing speed and EF performance across time points.

The secondary objective was to explore the moderating effect of sex on this association.

Methods

This study was a planned secondary analysis of data from Predicting Persistent Postconcussive Problems in Pediatrics, a prospective multicenter cohort study (hereafter referred to as the 5P study). The protocol and parent study have been previously published (Zemek et al., 2013, 2016). Participants in the parent study were enrolled from the emergency departments (EDs) of nine Canadian pediatric hospitals within the Pediatric Emergency Research Canada Network (Bialy et al., 2018). Families that qualified for the study were asked to provide written consent in all cases and patient assent where applicable. Participants from four of the participating hospitals were offered participation in a neuropsychological follow-up at 4- and 12-week post-injury. The research was completed following Helsinki Declaration and included the research ethics committee at each participating institution (Alberta Children's Hospital, Children's Hospital of Eastern Ontario, Ste-Justine Hospital, Toronto Sick Kids Hospital) approved the neuropsychological component of the study.

Study setting

Recruitment

The neuropsychological study used the same inclusion and exclusion criteria as the 5P protocol. Details of patient recruitment are outlined in the published 5P protocol (Zemek et al., 2013). Briefly, children aged 5 to 18 years presenting to the ED within 48 hours of a head injury and who met concussion diagnostic criteria according to the Zurich Consensus Statement on Concussion in Sport (McCrory et al., 2013) were potentially eligible for the study. Exclusion criteria included 1) Glasgow Coma Scale ≤ 13 , 2) absence of trauma as primary event, 3) any trauma-related abnormality on neuroimaging, 4) multisystem injury requiring hospitalization, 5) neurosurgical intervention, intubation, or intensive care unit admission, 6) intoxication at time of ED presentation, 7) severe communication difficulties (history of attention deficit hyperactivity disorder or learning disability was not exclusionary), 8) previous enrollment, 9) language barrier, 10) inability to complete the follow-up visits.

With the help of research assistants, participants answered questionnaires in electronic survey format using Research Electronic Data Capture (REDCap; Harris et al., 2009, 2019) in their first language (English or French) using a portable tablet computer. In addition to questions about patient demographics, parents completed the Acute Concussion Evaluation (Gioia et al., 2008), a 22-item dichotomous-item validated tool to objectively help diagnose concussion (as indicated by the presence of at least one symptom). Data were further collected on injury characteristics, history (prior concussion, headache, and developmental or psychiatric disorder), and both retrospective pre-injury and post-injury acute symptoms (physical, emotional, cognitive, and sleep) using the Post-Concussion Symptom Inventory (PCSI; Sady et al., 2013).

Follow-ups

The participants who consented to the neuropsychological component returned to the testing centers at 4 weeks and 12 weeks post-concussion (see Figure 1 for study endpoints). Each visit took approximately 2.5 hours, during which a comprehensive battery of neuropsychological measures was administered in their

first language (English or French). In addition to the neuropsychological test battery, participants completed the PCSI at 4 and 12 weeks. To be included in the present analyses, participants must have completed at least 85% of the neuropsychological outcome measures.

Outcome measures

Neuropsychological testing

A comprehensive battery of neuropsychological measures was administered to participants in this component of the study ($n = 311$). The battery included measures of intelligence, language, visual-spatial/motor functions, memory, processing speed, EF, and academic achievement (see Beauchamp et al., 2018 for a description of the neuropsychological test battery). The selection of the neuropsychological tests was grounded in the availability of standardized French and English versions across our study's age range, inclusion in the Common Data Elements (CDE) for concussion for cross-study comparisons and data sharing (Broglio et al., 2018), their utility for concussion assessment, and their capacity for a multifaceted assessment of higher order cognitive functioning. Selected measures for the present study include the Coding and Digit Span subtests of the Wechsler Intelligence Scale for Children Fourth Edition (WISC-IV; Wechsler, 2014) or the Wechsler Adult Intelligence Scale Fourth Edition (WAIS-IV; Wechsler, 2008), the Conners' Continuous Performance Test (CPT-II; Conners & Staff, 2000), and the Color-Word Interference Test and the Verbal Fluency subtests of the Delis-Kaplan Executive Functioning System (D-KEFS; Delis et al., 2001). The Medical Symptom Validity Test (MSVT) allowed for the assessment of performance validity and effort in a subset of participants at each visit (4 weeks $n = 72$; 12 weeks $n = 58$; Green, 2004). The MSVT was added to the neuropsychological test battery a year into the study, See Supplementary Material 1 for details. Specific outcome variables used in the current analysis are presented in Table 1. Psychometric characteristics for the neuropsychological measures are presented in Supplementary Material 2.

Post-concussion symptom inventory (PCSI)

The PCSI was used to measure symptom burden. The PCSI is a postconcussion symptom rating scale specifically adapted for children, adolescents, and their parents, with items that are developmentally appropriate and assist in differentiating concussed from non-concussed children and adolescents (Gioia et al., 2009; Sady et al., 2013). The PCSI has three self-rated symptom scales for children aged to 7 years (PCSI-SR5; 13 items on a three-point scale), 8 to 12 years (PCSI-SR8; 17 items on a three-point scale), and 13 to 18 years (PCSI-SR13; 20 items on a seven-point scale). The PCSI measures physical (e.g., visual problems, numbness or tingling, headache, balance problems, sensitivity to light or sound), cognitive (e.g., difficulty remembering, difficulty concentrating, feeling slowed down or thinking slowly, feeling mentally foggy), emotional (e.g., irritability, sadness, nervousness, feeling more emotional), and sleep-related symptoms (e.g., drowsiness, trouble falling asleep, sleeping more than usual).

Internal consistency was strong for the total PCSI symptom score for PCSI-SR8 and PCSI-SR13 in a concussed sample within 30 days of injury ($\alpha = .90-.94$; Sady et al., 2013). Test-retest reliability (3–14 days retest interval) coefficients for PCSI-SR8 and PCSI-SR13 in non-concussed children were moderate to strong (ICCs = .65–.89; Sady et al., 2013).

Table 1. Neuropsychological outcomes measured at 4 and 12 weeks following concussion

Neuropsychological Task	Outcomes Measure	Cognitive Domain(s) Measured
WISC-IV/WAIS-IV Coding	Scaled score	Processing speed and visual-motor coordination
WAIS-IV/WISC-IV Digit Span backward condition	Scaled score	Working memory
Conner's CPT-II	Omission t-score	Sustained attention, vigilance, and response inhibition
D-KEFS Color-Word Interference Test	Inhibition versus Color Naming contrast scaled score	Response inhibition and selective attention
D-KEFS Verbal Fluency, letter fluency condition	Scaled score	Phonemic fluency and cognitive flexibility

Note: CPT-II = Continuous Performance Test II; D-KEFS = Delis-Kaplan Executive Function System; WAIS-IV = Wechsler's Adult Intelligence Test Fourth Edition; WISC-IV = Wechsler's Intelligence Scale for Children Fourth Edition.

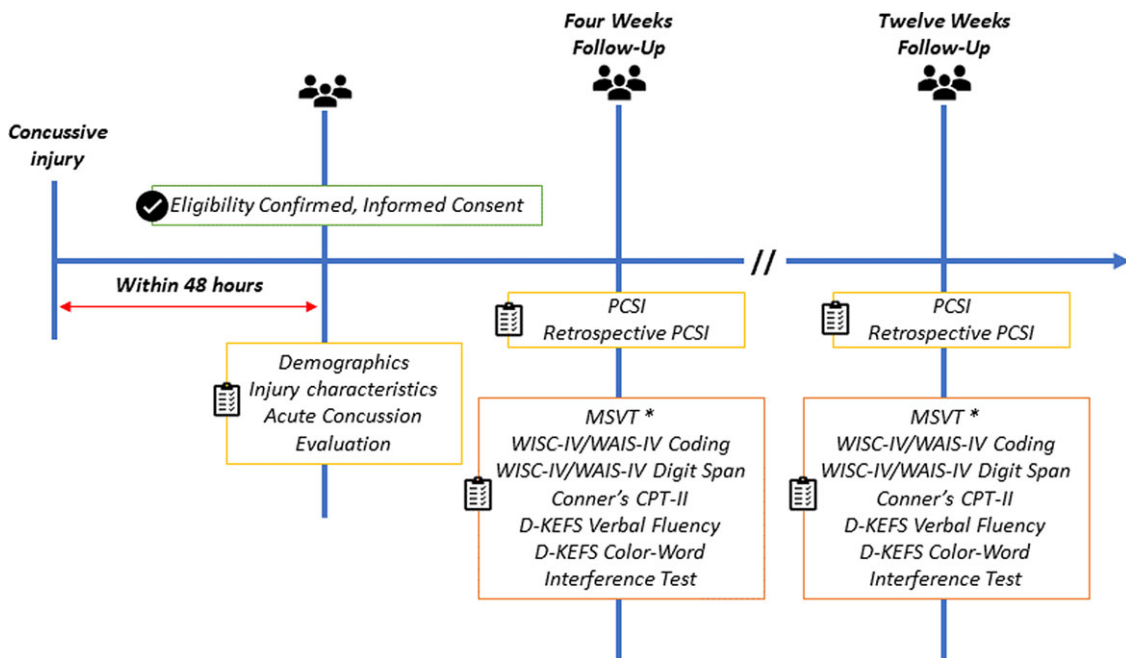

Figure 1. Study flow diagram. *Note.* CPT-II = Continuous Performance Test II; D-KEFS = Delis-Kaplan Executive Function System; MSVT = Medical Symptom Validity Test; PCSI = Post-Concussion Symptom Inventory children version; WAIS-IV = Wechsler Adult Intelligence Scale Fourth Edition; WISC-IV = Wechsler Intelligence Scale for Children Fourth Edition. * MSVT was completed by a subset of participants.

In the present study, the age-specific retrospective (pre-injury rating of symptoms) and current PCSI (yesterday and today's rating of symptoms) were administered at 4 and 12 weeks. Similar to previous studies (Gagnon et al., 2020; Ledoux et al., 2019; Lumba-Brown et al., 2020), symptom burden was defined as the absolute difference between current ratings and retrospective ratings (delta score).

For each item, both a current (post-injury) rating and a pre-injury rating are obtained, with the difference constituting the item "delta score." To ensure that participants of all age groups (5–7, 8–12, and 13–18) could be included in the same analyses, adjustments were made to account for the difference in scaling between age groups. We achieved this by uniformly rescaling all item mean delta scores to be consistent with the 7-point symptom rating scale used by the 13–18 years age group (i.e., rescaled to a range from 0 to 6). A higher symptom burden may indicate that an individual has more severe symptoms or a greater number of symptoms on post-injury assessments relative to pre-injury assessments.

Statistical analysis

Descriptive statistics were used to summarize the data. To examine the relationship between symptom burden and cognition,

generalized least squares models (Harrell, 2015b) were fitted with each of the five neuropsychological outcomes specified as dependent variables in separate models. Data were structured in a "long" format such that information from both time points could be concurrently assessed within the same statistical model, and a "week" variable (i.e., 4 or 12) was included to differentiate between study time points. Independent variables retained in these models include symptom burden, continuous age, sex, and the interaction between symptom burden and sex. The interaction between symptom burden and week was tested but was not significant and was not retained in any model. The following covariates were added to the five models: week (4 vs. 12 weeks), maximum symptom duration from previous concussions (no previous concussion; 1–2 weeks, 3–4 weeks; 5–8 weeks; more than 8 weeks), history of migraine, learning disability, attention deficit (hyperactivity) disorder, other developmental disorders, anxiety, depression, and sleep disorder; and mechanism of injury (sports/recreation; non-sport/fall; motor vehicle collision; assault).

Given repeated measurements and the clustered nature of the study data (i.e., subjects recruited from multiple study sites), compound symmetry covariance structure was applied to "week," with site specified as a grouping factor to correct for within-subject

correlation (i.e., participant nested within site). To allow for nonlinearity, restricted cubic splines (Harrell, 2015a) with four knots (placed at 5th, 35th, 65th, 95th quantiles) were specifically used for symptom burden; due to technical constraints, only three knots (placed at 10th, 50th, 90th quantiles) were applied for the models for inhibition and cognitive flexibility. A complete case analysis approach was conducted where observations with missing values on any covariate or outcome were excluded. After model fitting, multiple degrees-of-freedom Wald chi-square tests (inclusive of all linear and nonlinear components and any interaction terms) and associated *p*-values (two-sided) were obtained for all predictors to evaluate their association with each model outcome. A *p* < .05 was considered statistically significant. Where symptom burden was found to be associated with an EF measure, this relationship was further examined by graphical means (e.g., partial effect plots). Weighted contrasts based on sex and sex-specific contrasts were specified for 75th versus 25th quantiles, and for 90th versus 10th quantiles to provide estimates of effect size associated with symptom burden (high vs. low scores).

Sensitivity analyses were conducted to determine whether the main findings would significantly change if participants with invalid effort based on the MSVT (scores $\geq 85\%$ on the Immediate Recall, Delayed Recall, and Consistency metrics; (Green, 2004) were removed from the analyses. Details are presented in Supplementary Material 1. Briefly, crude analyses (i.e., with symptom burden as the only independent variable and week as the only covariate due to degrees of freedom constraints) were conducted for the full sample (*N* = 311) and parallel sensitivity analyses were conducted using only those with MSVT data (*N* = 95).

All analyses were performed using *R* version 4.0.3 (R Core Team, 2022), and statistical modeling was conducted with functions from the *rms* package (Harrell, 2023).

Results

Participants

311 children (202 males, 109 females) with a median age of 11.92 years (interquartile range, 9.14–14.21) were enrolled in the neuropsychological component of the study. Of those, 172 completed both follow-up assessments, 115 completed only the 4-week assessment, and 24 completed only the 12-week assessment (see Figure 2).

Table 2 presents participants' demographic and injury characteristics. Most children did not have a history of concussion before the eligible injury (71.9%) and most concussions were sport- or recreation-related (63.7%).

Only 103 (33.1%) participants completed the MSVT at either time point. Demographic and injury characteristics stratified by those who completed the MSVT and those who did not are presented in Supplementary Table 1. Participants who completed the MSVT had a higher prevalence of history of anxiety (12.7%) than those who did not complete the MSVT (5.8%), *p* = .03.

Association of symptom burden and cognitive functioning

Descriptive values for outcome measures at the 4- and 12-week follow-ups are presented in Table 3. Full results (i.e., all five Wald chi-square and five covariate effect tables) are presented in Supplementary Material 2.

Higher symptom burden was significantly associated with lower scores on the Backward Digit Span, $\chi^2(df = 4) = 9.85, p = .04$

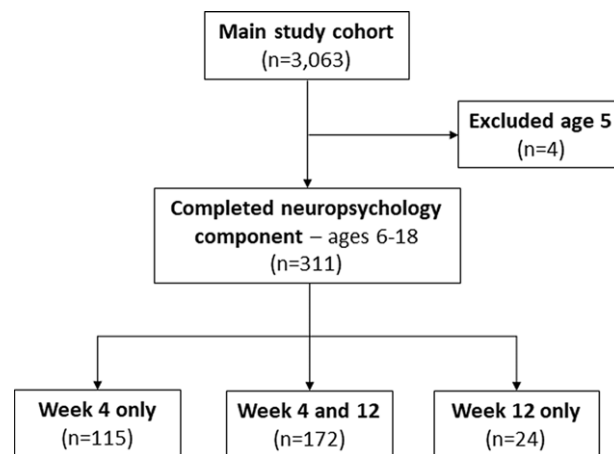

Figure 2. Flowchart of recruitment for the main study and those enrolled in the neuropsychological component in four of the study sites.

[75th vs. 25th quantiles: Estimate = -0.59 (95%CI = $-1.15, -0.03$); 90th vs. 10th quantiles: Estimate = -0.82 (95%CI = $-1.48, -0.16$)]. The interaction of symptom burden and sex was not significant, *ps* $\geq .32$, see Figure 3. Because sex was not significant, sex-specific contrasts are presented in Supplementary Material 2. Moreover, older age (nonlinear) and history of learning disability were associated with lower scores on Backward Digit Span, *ps* $\leq .02$.

Similarly, higher symptom burden was significantly associated with lower scores on Verbal Fluency, $\chi^2(df = 4) = 10.48, p = .03$ [75th vs. 25th quantiles: Estimate = -0.29 (95%CI = $-0.95, 0.36$); 90th vs. 10th quantiles: Estimate = -0.57 (95%CI = $-1.27, 0.14$)]. The interaction of symptom burden and sex was not significant, *ps* $\geq .20$, see Figure 4. Because sex was not significant, sex-specific contrasts are presented in Supplementary Material 2. Moreover, week 4 (vs. 12) assessment and history of Learning Disability were associated with lower scores on Verbal Fluency, *ps* $\leq .01$.

Neither symptom burden nor the interaction of symptom burden and sex were significant predictors of scores on the Coding, CPT-II, and Color Word Interference tests, *ps* $\geq .17$. However, other covariates in these three models were significant. History of migraine, history of learning disability, and symptom duration from previous concussion(s) of 3–4 weeks, 5–8 weeks or >8 weeks were associated with lower scores on the Coding task, *ps* $\leq .05$. Female sex, week 12 (vs. 4) assessment, history of sleep disorder, and symptom duration from previous concussion(s) of <1 week or 1–2 week were associated with higher scores on the Coding task, *ps* $\leq .05$. Older age was associated with lower scores on the CPT-II, *ps* < .001, while history of learning disability was associated with higher scores on the CPT-II, *p* = .005. Finally, history of developmental disorders was associated with lower scores on the Color-Word Interference test, *p* = .05.

Sensitivity analyses Detailed results are presented in Supplementary Material 1. At 4 weeks, 68 (21.9%) participants had a valid performance on the MSVT, 3 (1.0%) had an invalid performance, and 240 (77.2%) had no MSVT scores. At 12 weeks, 53 (17.0%) participants had a valid performance, 5 (1.6%) had an invalid performance, and 253 (81.4%) had no MSVT scores. Importantly, scores on the five neuropsychological tasks did not differ between those with valid performance on the MSVT/no MSVT and those with invalid MSVT at both time points, *ps* $\geq .16$.

95 participants were included in the sensitivity analyses. For WISC-IV/WAIS-IV Backward Digit Span, the crude analysis of the

Table 2. Participant demographic information

Variable	<i>n</i>	Value
Sex, freq (%)	311	
Female		109 (35.0)
Male		202 (65.0)
Age, median [IQR]	311	11.92 [9.14, 14.21]
Time between head injury and triage (hours), median [IQR]	309	3.25 [1.65, 17.15]
Previous number of concussion(s), freq (%)	310	
0		223 (71.9)
1		59 (19.0)
2		18 (5.8)
3		7 (2.3)
4		3 (1.0)
Maximum symptom duration from previous concussion(s) (weeks), freq (%)	308	
Never had a concussion		223 (72.4)
<1 week		33 (10.7)
1–2 weeks		23 (7.5)
3–4 weeks		12 (3.9)
5–8 weeks		7 (2.3)
>8 weeks		10 (3.2)
History of migraine, freq (%)	309	39 (12.6)
History of learning disability, freq (%)	310	29 (9.4)
History of attention deficit disorder, freq (%)	310	24 (7.7)
History of developmental disorder, freq (%)	308	11 (3.6)
History of anxiety, freq (%)	310	25 (8.1)
History of depression, freq (%)	311	9 (2.9)
History of sleep disorder, freq (%)	311	10 (3.2)
Mechanism of injury, freq (%)	311	
Sports/Recreation		198 (63.7)
Non-sport/Fall		102 (32.8)
Motor vehicle collision		7 (2.3)
Assault		4 (1.3)
Loss of consciousness, freq (%)	311	
No		244 (78.5)
Yes		33 (10.6)
Unknown		34 (10.9)
Duration of loss consciousness, median [IQR]	31	0.50 [0.15, 1.00]
Seizure following injury, freq (%)	311	8 (2.6)
Symptom burden at initial ED visit, median [IQR]	302	1.76 [1.06, 2.47]
Academic achievement prior to concussion, freq (%)	308	
Straight A student		83 (26.9)
A & B grades		122 (39.6)
Straight B student		55 (17.9)
B & C grades		39 (12.7)
Below C grades		9 (2.9)

Note: ED = Emergency Department. Symptom burden is operationalized as the average item delta score (post-injury minus retrospective pre-injury, rescaled 0–6) on the Post-Concussion Symptom Inventory self-report, age-appropriate version.

Table 3. Outcome variables at 4 weeks and 12 weeks post-concussion

Measures	4 weeks				12 weeks			
	N	Median [IQR]	Min	Max	N	Median [IQR]	Min	Max
Symptom burden	284	0.20 [0.00, 0.88]	0.00	3.88	273	0.05 [0.00, 0.53]	0.00	3.88
WISC-IV/WAIS-IV Coding	287	10.00 [8.00, 11.00]	1.00	17.00	196	10.00 [8.00, 13.00]	1.00	18.00
WISC-IV/WAIS-IV Backward Digit Span	287	10.00 [9.00, 12.00]	3.00	17.00	196	10.50 [8.75, 12.00]	3.00	18.00
Conner's CPT-II	271	46.96 [43.76, 53.02]	40.06	161.44	183	46.96 [44.04, 52.82]	40.06	130.41
D-KEFS Color-Word Interference Test	236	10.00 [9.00, 11.00]	3.00	17.00	163	10.00 [9.00, 12.00]	4.00	17.00
D-KEFS Verbal Fluency	245	9.00 [7.00, 12.00]	2.00	19.00	172	11.00 [8.00, 12.00]	2.00	19.00

Note: CPT-II = Continuous Performance Test II; D-KEFS = Delis-Kaplan Executive Function System; WAIS-IV = Wechsler Adult Intelligence Scale Fourth Edition; WISC-IV = Wechsler Intelligence Scale for Children Fourth Edition. Symptom burden is operationalized as the average item delta score (post-injury minus retrospective pre-injury, rescaled 0–6) on the Post-Concussion Symptom Inventory self-report, age-appropriate version.

full sample revealed symptom burden as a significant predictor ($p = .02$), while in the sensitivity analysis, only week of assessment was significant ($p = .003$). For the D-KEFS Color Word Interference Test, the sensitivity analysis revealed that symptom burden was a significant predictor ($p = 0.04$), while no predictors were significant in the crude analysis. For D-KEFS Verbal

Fluency, symptom burden and week of assessment were significant ($ps \leq .03$) in the crude analysis, while the sensitivity analysis showed only week as a significant predictor ($p < .001$). For both the WISC-IV/WAIS-IV Coding and Conner's CPT-II Omission, the results were similar between crude and sensitivity analyses.

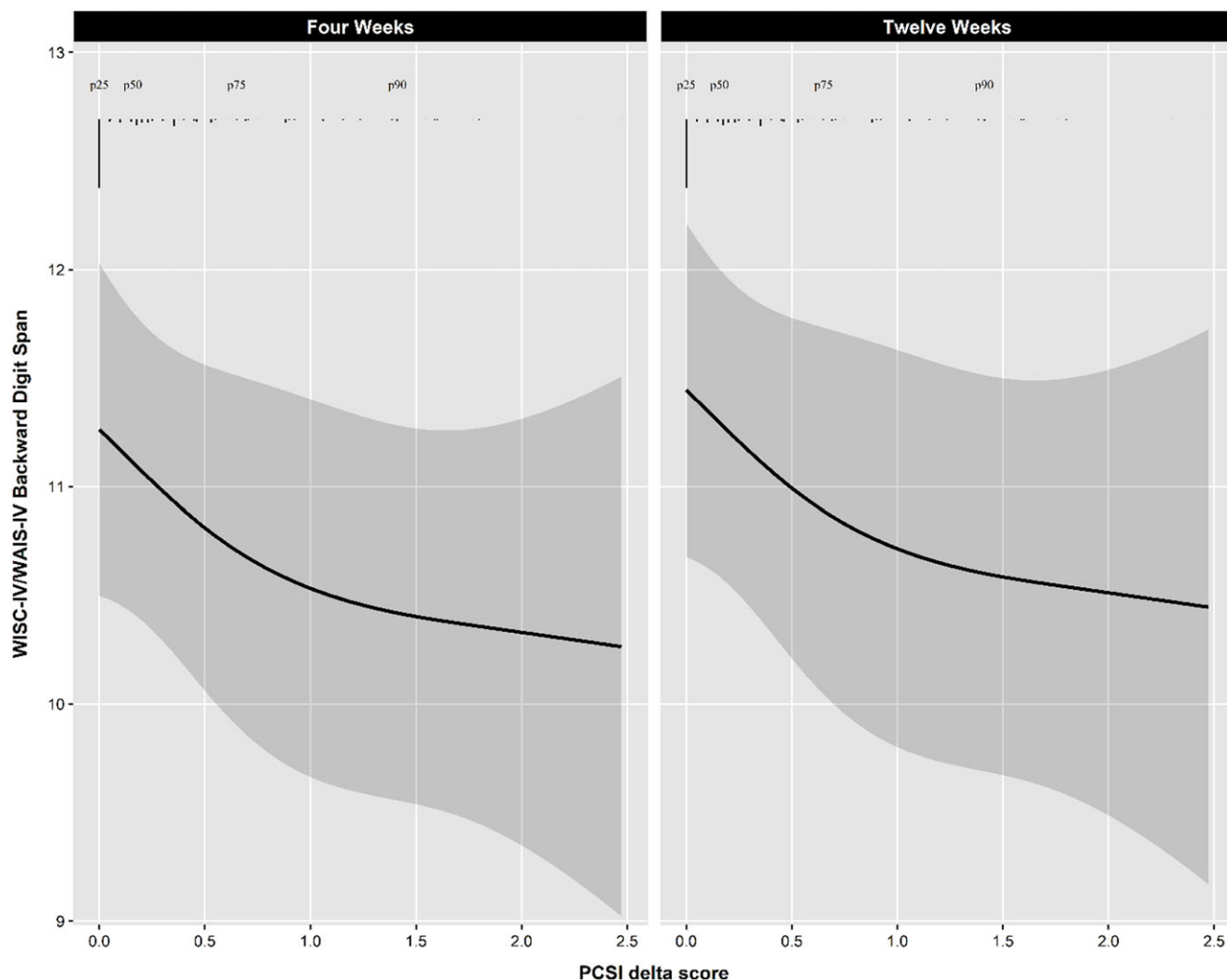

Figure 3. Graphical representation of the negative association between the symptom burden measured by the Post-Concussion Symptom Inventory (PCSI) the t-score on the Backward Digit Span subtest of the Wechsler's Intelligence Scale for Children Fourth Edition/Wechsler's Adult Intelligence Scale Fourth Edition (WISC-IV/WAIS-IV) at 4 weeks and 12 weeks following pediatric concussion. *Note.* Adjusted to: age = 11.92, maximum symptom duration from previous concussion(s) (weeks) = never had concussion, history of learning disabilities = no, history of attention deficit disorder = no, history of depression = no, history of anxiety = no, history of developmental disorders = no, history of sleep disorder = no, personal history of migraine = no, mechanism of Injury = sports/recreation.

Discussion

In this large prospective cohort pediatric concussion study, greater symptom burden was associated with lower scores on the WISC-IV/WAIS-IV Backward Digit Span and D-KEFS Verbal Fluency neuropsychological tests at 4- and 12-week post-concussion, after adjusting for several characteristics known to be associated with symptom reporting and cognitive functioning. These associations remained consistent over time and were not moderated by sex. Symptom burden was not associated with performance on the WISC-IV/WAIS-IV Coding, CPT-II, and D-KEFS Color-Word Interference tasks.

The WISC-IV/WAIS-IV Backward Digit Span is a measure of working memory, which refers to the ability to temporarily store and manipulate information that is no longer perceptually present (Baddeley & Hitch, 1994). The D-KEFS Verbal Fluency is considered a measure of cognitive flexibility, which involves the ability to switch between mental sets, tasks, or strategies, and our

ability to adapt to the constantly changing environment (Diamond, 2013; Miyake & Friedman, 2012). Previous studies have demonstrated that performance on both the Digit Span Backwards and Verbal Fluency tests are affected by pediatric concussion. Specifically, children and adolescents with a concussion scored lower on the Verbal Fluency subtest and the Digit Span Backwards condition in the subacute (i.e., within 11 days post-injury) and early chronic phase (i.e., approximately 4 months) of injury when compared to a typically developing comparison group (Sicard et al., 2022). However, in the later study, group comparisons were not stratified based on post-concussion symptoms, and the association between symptom burden and cognitive function was not investigated. While the cognitive differences between concussion and comparison groups are subtle, exploring whether these differences are associated with symptom burden can contribute to a more comprehensive understanding of pediatric concussion and inform approaches to management and intervention.

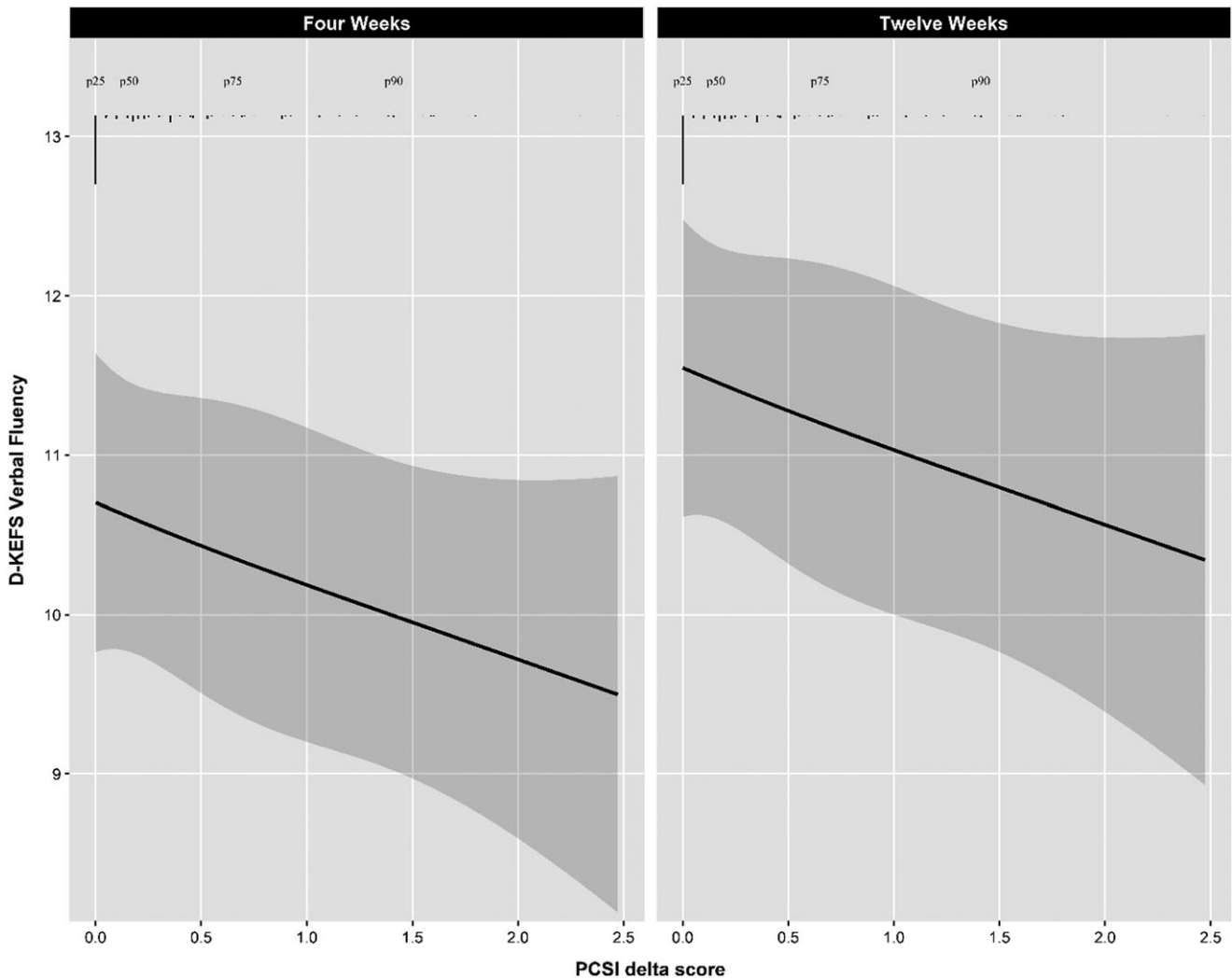

Figure 4. Graphical representation of the negative association between the symptom burden measured by the Post-Concussion Symptom Inventory (PCSI) and the scaled score on the Verbal Letter Fluency subtest of the Delis-Kaplan Executive Function System battery (D-KEFS) at 4 weeks and 12 weeks following pediatric concussion. *Note.* Adjusted to: age = 11.92, maximum symptom duration from previous concussion(s) (weeks) = never had concussion, history of learning disabilities = no, history of attention deficit disorder = no, history of depression = no, history of anxiety = no, history of developmental disorders = no, history of sleep disorder = no, personal history of migraine = no, mechanism of Injury = sports/recreation.

Previous studies found that greater symptom burden was associated with lower cognitive performance on a computerized nonverbal working memory task on average 6 days following pediatric concussion (Green et al., 2018), on a computerized task assessing processing speed and attention within 11 days post-injury (Sicard, Hergert, et al., 2021), and on paper-and-pencil tasks of verbal learning, verbal fluency, and mathematical fluency within a month post-injury (Jones et al., 2023). While the present study employed paper-and-pencil neuropsychological tests measuring different constructs, used delta scores rather than post-concussion scores alone, and examined time points further removed from the concussive event, our findings align with these previous studies in finding significant associations between symptom burden and EF measures.

In the current study, we opted to utilize symptom burden as the independent variable in our models and cognitive test performance as the dependent variable, aligning with the approach employed in previous research. By doing so, we aimed to maintain consistency

and facilitate comparisons with existing research in pediatric concussion. However, the associations observed in the current study do not imply causation and further studies are required to fully understand the relationship between symptoms and cognitive outcomes after a pediatric concussion. The associations may be bidirectional, implying a reciprocal relationship between the two types of outcomes. On one hand, symptoms may have a detrimental impact on cognitive performance. The presence of physical discomfort, headaches and pain, or emotional distress associated with the symptoms can serve as distractions, making it more challenging to concentrate, remember information, or engage in complex cognitive tasks. Moreover, symptoms such as sleep disturbances and mood changes can directly affect cognitive efficiency. On the other hand, lower EF can contribute to the experience of symptoms. Difficulties in working memory and cognitive flexibility can impede the ability to effectively regulate cognitive and behavioral processes, potentially leading to the emergence or exacerbation of symptoms commonly associated

with concussion, such as headaches, fatigue, difficulties concentrating/remembering, and mood changes. Thus, cognitive difficulties and symptom burden may reinforce each other in a feedback loop, potentially leading to a cycle of worsening symptoms and declining EF if not effectively managed. By recognizing that lower cognitive functioning can contribute to symptom burden, and vice versa, healthcare providers and researchers can better address the complex interplay between symptoms and cognitive performance. Future studies using cross-lagged panel designs can help investigate the direction of causality between cognitive functioning and symptomatology, shedding light on potential causal relationships and providing valuable insights for targeted interventions.

Novel to this study was the exploration of the effect of sex on the association of symptoms and cognitive functioning following pediatric concussion. The significant associations between symptom burden and EF measures observed were not moderated by sex. This finding challenges previous observations that males and females may experience different symptom burden or cognitive outcomes following concussion (Alsalaheen et al., 2021; Broshek et al., 2005; Brown et al., 2015; Covassin et al., 2012, 2018; Hannah et al., 2021; Howell et al., 2018; Koerte et al., 2020; Merritt et al., 2019; Mollayeva et al., 2019; Sicard et al., 2018; Yeates et al., 2022; Zemek et al., 2016). The present null findings could indicate that a combination of various factors, including but not limited to symptom burden, may interact, and associate with cognitive outcomes following concussion. Including factors such as age, history of psychological and neurodevelopmental comorbidities, and migraines might have reduced the influence of sex on the association between symptom burden and cognitive functioning in the present study. While including these factors in the model can reduce the influence of sex on the association between symptom burden and cognitive functioning, it does not necessarily mean that sex is not a relevant factor. Given the limited available data, more research is needed to understand how biological sex, as well as gender identity, and other personal characteristics, may moderate the interaction between symptoms and EF following pediatric concussion.

The present analysis is not only novel, but also builds upon our previously published research, which found that 10.3% of children in the current sample exhibited cognitive impairments (i.e., 2 or more subtests on a battery of 10 tasks having a score of 1.5 SD below the mean) at 4 weeks, and 4.5% by 12 weeks (Beauchamp et al., 2018). The observed association between symptoms and EF has important clinical implications, suggesting that children who experience symptoms may also have difficulties with working memory and cognitive flexibility. Intervention strategies aiming at simultaneously decreasing symptoms and improving cognitive functioning, such as active rehabilitation and psychosocial intervention, may help promote recovery and improve the ability to return to school, to learning, and sports. In cases where children are athletes, the association between symptom burden and EF may have implications for return-to-play decisions, as alterations of EF may increase the risk of re-injury (Bertozzi et al., 2023; McPherson et al., 2019; Wilke & Groneberg, 2022). Overall, the association between symptoms and cognitive functioning highlights the importance of considering cognitive outcomes, even if subtle, in the management of concussion, and emphasizes the need for multidisciplinary approaches to promote optimal recovery and functional outcomes.

The present study is characterized by numerous strengths, including the longitudinal assessment of symptom burden and

cognition, multifaceted assessment of EF (i.e., multiple domains), inclusion of primary school-age children and non-sport-related concussions, and relatively large sample size. Methodological limitations should also be acknowledged. First, participants were recruited from an ED setting, so the findings may not generalize to those seeking care outside of the ED (e.g., specialty care clinic or sports medicine clinic), those not seeking medical care, or those with delayed symptom presentation (48 to 72 hours post-injury). Second, the lack of pre-injury data and the absence of a comparison group does not allow us to definitively attribute symptoms and lower cognitive performance to the concussion. The absence of true pre-injury symptom ratings may be seen as a limitation. The retrospective nature of symptom reporting introduces the possibility of “good old day bias,” wherein participants might inadvertently recall their pre-injury symptoms as less severe than their actual experiences, potentially influencing the study’s outcomes. However, a large prospective study indicated that children and adolescents recall their retrospective pre-injury symptom ratings with good-to-perfect stability over the first 3 months following their concussion (Teel et al., 2019).

Third, the use of delta scores, though common, might introduce technical constraints and limitations that warrant acknowledgment. Delta scores may not precisely capture the true magnitude of change, particularly in our specific context where rescaling the delta score was necessary, thereby adding a layer of complexity to interpretation. Nevertheless, the approach used ensures comparable scoring of symptom burden across different age groups and allows for comparison with previous studies (Gagnon et al., 2020; Ledoux et al., 2021; Lumba-Brown et al., 2020). However, prior research suggests that employing standardized change algorithms, such as reliable change indices, is more suitable than simple change scores for assessing the prevalence of persisting symptoms after concussion (Mayer et al., 2020). As such, future investigations should validate reliable change indices for the PCSI across age groups and injury phases, akin to the approach applied to another frequently used symptom scale in pediatric concussion research (O’Brien et al., 2021). Fourth, performance validity during was not assessed for all participants in this study, as validity testing was added to the assessment battery after the first year of enrollment. Nevertheless, the sensitivity analysis suggests that the outcomes are unlikely to be significantly influenced by validity considerations. Future studies should incorporate measures of test and symptom validity in their neuropsychological battery, similar to a recently published paper that investigated IQ after pediatric concussion (Ware et al., 2023). Fifth, whether specific symptoms or symptom subtypes were associated with lower cognitive functioning was not investigated, although previous adult studies found an association between headaches and cognitive functioning within 1 month (on average 6 days) and longer (range = 6–36 months) post-concussion. Herein, we anticipated a significant portion of our participants would have already experienced symptom resolution by the time of assessment, as the proportion of children identified with persisting symptoms after concussion was 35.1% in a recent meta-analysis (Chadwick et al., 2022). The limited number of individuals presenting with specific symptoms at the 4-week and 12-week time points combined with the heterogeneous nature of post-concussion symptoms would not have been sufficient to conduct a comprehensive analysis of the association between these symptoms and cognitive functioning. By assessing overall symptom burden, we captured a broader spectrum of symptoms and their collective association with cognitive functioning. Finally, the present dataset does not allow for causality assessment, for

which alternative analytic approaches would be required, such as cross-lagged panel models or structural equation modeling, which are not feasible with our dataset. Nevertheless, our analytical approach leveraged the longitudinal nature of the data by treating symptom burden as a time-varying covariate. This allowed us to examine how symptoms are associated with changes in cognition, providing insights into the dynamics of the relationship over time.

Conclusions

The current study shows modest negative associations of symptom burden with both working memory and cognitive flexibility several weeks following a pediatric concussion. More research on cognition and persisting symptoms after concussion is warranted to provide an improved standard of care, targeted management strategies, and optimize recovery and functional outcomes, as suggested by the recent systematic review of the Concussion in Sports Group (Yeates et al., 2023).

Supplementary material. The supplementary material for this article can be found at <https://doi.org/10.1017/S1355617724000043>.

Acknowledgments and Funding. This study was supported by project funding from the Canadian Institutes of Health Research (RZ 293380). We would like to acknowledge the input and contributions of the entire 5P study team, with particular thanks to the coordinators and assistants at the neuropsychology substudy sites.

Competing interests. VS received royalties for the sales of a concussion book (Commotions Cérébrales) by Flammarion Québec.

KOY receives an editorial stipend from the American Psychological Association. He is an unpaid member of the Scientific Advisory Committee for Brain Injury Canada. He is the principal investigator on grants from the Canadian Institutes of Health Research (CIHR) and is a co-investigator on research grants from CIHR, the US National Institutes of Health (NIH), Brain Canada Foundation, and the National Football League Scientific Advisory Board. He receives book royalties from Guilford Press and Cambridge University Press. He has received travel support and an honorarium for presentations to multiple organizations. He receives honorarium for serving on the following groups: Independent Data Monitoring Committee (IDMC), Care for Post-Concussive Symptoms Effectiveness (CARE4PCS-2) Trial, National Institute for Child Health and Human Development; Observational Study Monitoring Board (OSMB), Approaches and Decisions in Acute Pediatric TBI (ADAPT) Trial, National Institute of Neurological Disorders and Stroke; National Research Advisory Council, National Pediatric Rehabilitation Resource Center, Center for Pediatric Rehabilitation: Growing Research, Education, and Sharing Science (C-PROGRESS), Virginia Tech University.

BB receives royalties for the sales of three pediatric neuropsychological measures (ChAMP, MEMRY, and MVP) and royalties for the sale of a textbook (Pediatric Forensic Neuropsychology). He has a private practice where he provides assessments for people with concussion, he is a paid consultant with the NHL Concussion program, and he has received grant funding to study concussion.

MB receives royalties for the sales of a textbook (Pediatric Neuropsychology). She receives grants and philanthropic funding to study pediatric concussion. She has received travel support and honorarium for presentations to multiple organizations.

MK received grants and philanthropic funding to study pediatric concussion. She has received travel support and honorarium for presentations to multiple organizations. She has provided assessment for children, youth, and adults with concussion in a private practice setting and as a medical legal assessor. MK is currently a contractor at FIREFLY, a Northwestern Ontario FASD Diagnostic Clinic and Autism Diagnostic Hub, and at Mackenzie Health, Centre for Behaviour and Health Sciences.

RZ's program of research has received financial support through competitively funded research grants from Canadian Institutes of Health Research (CIHR), Ontario Neurotrauma Foundation (ONF), Physician Services

Incorporated (PSI) Foundation, CHEO Foundation, Ontario Brain Institute (OBI), National Football League (NFL), Ontario Ministry of Health (MOH), Public Health Agency of Canada (PHAC), Health Canada, Parachute Canada and Ontario SPOR Support Unit (OSSU). RZ is also supported by a Tier 1 Clinical Research Chair in Pediatric Concussion from University of Ottawa. All grant funding goes directly to the institution. RZ sits on the board of directors for North American Brain Injury Society (NABIS) which is a volunteer (unpaid) role. Finally, RZ is a founding partner and a minority shareholder of 360 Concussion Care (a learning health system and network of interdisciplinary concussion clinics in Ontario); no proceeds have been transferred to RZ.

The remaining authors have no conflicts of interest to report.

References

- Alsalaheen, B., Almeida, A., Eckner, J., Freeman, J., Ichesco, I., Popovich, M., Streicher, N., Lorincz, M. (2021). Do male and female adolescents report symptoms differently after concussion? *Brain Injury*, 35(6), 698–704. <https://doi.org/10.1080/02699052.2021.1896034>
- Anzalone, C., Bridges, R. M., Luedke, J. C., & Decker, S. L. (2022). Neurocognitive correlates of persisting concussion symptoms in youth. *Applied Neuropsychology: Child*, 11(4), 771–780. <https://doi.org/10.1080/21622965.2021.1961260>
- Babcock, L., Byczkowski, T., Wade, S. L., Ho, M., Mookerjee, S., & Bazarian, J. J. (2013). Predicting postconcussion syndrome after mild traumatic brain injury in children and adolescents who present to the emergency department. *JAMA Pediatrics*, 167(2), 156–161. <https://doi.org/10.1001/jamapediatrics.2013.434>
- Baddeley, A. D., & Hitch, G. J. (1994). Developments in the concept of working memory. *Neuropsychology*, 8(4), 485–493.
- Baillargeon, A., Lassonde, M., Leclerc, S., & Ellemberg, D. (2012). Neuropsychological and neurophysiological assessment of sport concussion in children, adolescents and adults. *Brain Injury*, 26(3), 211–220. <https://doi.org/10.3109/02699052.2012.654590>
- Beauchamp, M. H., Aglipay, M., Yeates, K. O., Désiré, N., Keightley, M., Anderson, P., Brooks, B. L., Barrowman, N., Gravel, J., Boutis, K., Gagnon, I., Dubrovsky, A. S., Zemek, R. (2018). Predictors of neuropsychological outcome after pediatric concussion. *Neuropsychology*, 32(4), 495–508. <https://doi.org/10.1037/neu0000419>
- Bertozzi, F., Fischer, P. D., Hutchison, K. A., Zago, M., Sforza, C., & Monfort, S. M. (2023). Associations between cognitive function and ACL injury-related biomechanics: A systematic review. *Sports Health: A Multidisciplinary Approach*, 15(6), 855–866. <https://doi.org/10.1177/19417381221146557>
- Bialy, L., Plint, A., Zemek, R., Johnson, D., Klassen, T., Osmond, M., & Freedman, S. B. (2018). Pediatric emergency research Canada: Origins and evolution. *Pediatric Emergency Care*, 34(2), 138–144. <https://doi.org/10.1097/PEC.0000000000001360>
- Broglio, S. P., Kontos, A. P., Levin, H., Schneider, K., Wilde, E. A., Cantu, R. C., Feddermann-Demont, N., Fuller, G. W., Gagnon, I., Gioia, G. A., Giza, C., Griesbach, G. S., Leddy, J. J., Lipton, M. L., Mayer, A. R., McAllister, T. W., McCrea, M., McKenzie, L. B., Putukian, M., Signoretti, S., Suskauer, S. J., Tamburro, R., Turner, M., Yeates, K. O., Zemek, R., Ala'i, S., Esterlitz, J., Gay, K., Bellgowan, P. S. F., Joseph, K., Sport-Related Concussion CDE Working Group (2018). National Institute of Neurological Disorders and Stroke and Department of Defense Sport-Related Concussion Common Data Elements version 1.0 recommendations. *Journal of Neurotrauma*, 35(23), 2776–2783. <https://doi.org/10.1089/neu.2018.5643>
- Broshek, D. K., Kaushik, T., Freeman, J. R., Erlanger, D., Webbe, F., & Barth, J. T. (2005). Sex differences in outcome following sports-related concussion. *Journal of Neurosurgery*, 102(5), 856–863. <https://doi.org/10.3171/jns.2005.102.5.0856>
- Brown, D. A., Elsass, J. A., Miller, A. J., Reed, L. E., & Reneker, J. C. (2015). Differences in symptom reporting between males and females at baseline and after a sports-related concussion: A systematic review and meta-analysis. *Sports Medicine (Auckland, N.Z.)*, 45(7), 1027–1040. <https://doi.org/10.1007/s40279-015-0335-6>
- Chadwick, L., Roth, E., Minich, N. M., Taylor, H. G., Bigler, E. D., Cohen, D. M., Bacevice, A., Mihalov, L. K., Bangert, B. A., Zumberge, N. A., & Yeates, K. O. (2021). Cognitive outcomes in children with mild traumatic brain injury: An

- examination using the national institutes of health toolbox cognition battery. *Journal of Neurotrauma*, 38(18), 2590–2599. <https://doi.org/10.1089/neu.2020.7513>
- Chadwick, L., Sharma, M. J., Madigan, S., Callahan, B. L., & Owen Yeates, K. (2022). Classification criteria and rates of persistent postconcussive symptoms in children: A systematic review and meta-analysis. *The Journal of Pediatrics*, 246, 131–137.e2. <https://doi.org/10.1016/j.jpeds.2022.03.039>
- Conners, C. K., & Staff, M. (2000). *Conners' continuous performance test, version 5 for Windows* (2nd ed). Multi-Health Systems, Inc.
- Covassin, T., Elbin, R. J., Harris, W., Parker, T., & Kontos, A. (2012). The role of age and sex in symptoms, neurocognitive performance, and postural stability in athletes after concussion. *The American Journal of Sports Medicine*, 40(6), 1303–1312. <https://doi.org/10.1177/0363546512444554>
- Covassin, T., Savage, J. L., Bretzin, A. C., & Fox, M. E. (2018). Sex differences in sport-related concussion long-term outcomes. *International Journal of Psychophysiology: Official Journal of the International Organization of Psychophysiology*, 132(Pt A), 9–13. <https://doi.org/10.1016/j.ijpsycho.2017.09.010>
- DeCasien, A. R., Guma, E., Liu, S., & Raznahan, A. (2022). Sex differences in the human brain: A roadmap for more careful analysis and interpretation of a biological reality. *Biology of Sex Differences*, 13(1), 43. <https://doi.org/10.1186/s13293-022-00448-w>
- Delis, D. C., Kaplan, E., & Kramer, J. H. (2001). *Delis-Kaplan Executive Function System*. APA PsycTests.
- Diamond, A. (2013). Executive functions. *Annual review of psychology*, 64, 135–168. <https://doi.org/10.1146/annurev-psych-113011-143750>
- Gagnon, I., Teel, E., Gioia, G., Aglipay, M., Barrowman, N., Sady, M., Vaughan, C., & Zemek, R. (2020). Parent-child agreement on postconcussion symptoms in the acute postinjury period. *Pediatrics*, 146(1), 20192317.
- Giedd, J. N., & Rapoport, J. L. (2010). Structural MRI of pediatric brain development: What have we learned and where are we going? *Neuron*, 67(5), 728–734. <https://doi.org/10.1016/j.neuron.2010.08.040>
- Gioia, G. A., Collins, M., & Isquith, P. K. (2008). Improving identification and diagnosis of mild traumatic brain injury with evidence. *Journal of Head Trauma Rehabilitation*, 23(4), 230–242. <https://doi.org/10.1097/01.HTR.0000327255.38881.ca>
- Gioia, G. A., Schneider, J. C., Vaughan, C. G., & Isquith, P. K. (2009). Which symptom assessments and approaches are uniquely appropriate for paediatric concussion? *British Journal of Sports Medicine*, 43(Suppl_1), i13–i22. <https://doi.org/10.1136/bjism.2009.058255>
- Green, P. (2004). *Medical Symptom Validity Test (MSVT) for microsoft windows: User's manual*. Paul Green Pub.
- Green, S., Keightley, M. L., Lobaugh, N. J., Dawson, D. R., & Mihailidis, A. (2018). Changes in working memory performance in youth following concussion. *Brain Injury*, 32(2), 182–190. <https://doi.org/10.1080/02699052.2017.1358396>
- Gur, R. E., & Gur, R. C. (2016). Sex differences in brain and behavior in adolescence: Findings from the Philadelphia Neurodevelopmental Cohort. *Neuroscience and Biobehavioral Reviews*, 70, 159–170. <https://doi.org/10.1016/j.neubiorev.2016.07.035>
- Guty, E., & Arnett, P. (2018). Post-concussion symptom factors and neuropsychological outcomes in collegiate athletes. *Journal of the International Neuropsychological Society: JINS*, 24(7), 684–692. <https://doi.org/10.1017/S135561771800036X>
- Guty, E., Riegler, K., Meyer, J., Walter, A. E., Slobounov, S. M., & Arnett, P. (2021). Symptom factors and neuropsychological performance in collegiate athletes with chronic concussion symptoms. *Archives of Clinical Neuropsychology: The Official Journal of the National Academy of Neuropsychologists*, 36(5), 746–756. <https://doi.org/10.1093/arclin/aaaa092>
- Haider, M. N., Leddy, J. J., Pavlesen, S., Kluczynski, M., Baker, J. G., Miecznikowski, J. C., & Willer, B. S. (2018). A systematic review of criteria used to define recovery from sport-related concussion in youth athletes. *British Journal of Sports Medicine*, 52(18), 1179–1190. <https://doi.org/10.1136/bjsports-2016-096551>
- Halterman, C. I., Langan, J., Drew, A., Rodriguez, E., Osternig, L. R., Chou, L.-S., & Van Donkelaar, P. (2006). Tracking the recovery of visuospatial attention deficits in mild traumatic brain injury. *Brain*, 129(3), 747–753. <https://doi.org/10.1093/brain/awh705>
- Hannah, T. C., Li, A. Y., Spiera, Z., Kuohn, L., Dai, J., McAuley, F., Ali, M., Durbin, J. R., Dreher, N., Marayati, N. F., Gometz, A., Lovell, M., & Choudhri, T. (2021). Sex-related differences in the incidence, severity, and recovery of concussion in adolescent student-athletes between 2009 and 2019. *The American Journal of Sports Medicine*, 49(7), 1929–1937. <https://doi.org/10.1177/03635465211008596>
- Harrell, J. F. (2015a). Chapter 2: General aspects of fitting regression models. In *Regression Modeling Strategies* (2nd ed. pp. 24–28). Springer.
- Harrell, J. F. (2015b). Chapter 7: Modeling longitudinal responses using generalized least squares. In *Regression Modeling Strategies* (2nd ed.). Springer.
- Harrell, J. F. *rms: Regression modeling strategies* (2023). <https://cran.r-project.org/package=rms>.
- Harris, P. A., Taylor, R., Minor, B. L., Elliott, V., Fernandez, M., O'Neal, L., McLeod, L., Delacqua, G., Delacqua, F., Kirby, J., & Duda, S. N. (2019). The REDCap consortium: Building an international community of software platform partners. *Journal of Biomedical Informatics*, 95, 103208. <https://doi.org/10.1016/j.jbi.2019.103208>
- Harris, P. A., Taylor, R., Thielke, R., Payne, J., Gonzalez, N., & Conde, J. G. (2009). Research electronic data capture (REDCap)—A metadata-driven methodology and workflow process for providing translational research informatics support. *Journal of Biomedical Informatics*, 42(2), 377–381. <https://doi.org/10.1016/j.jbi.2008.08.010>
- Hou, X., Zhang, Y., Fei, X., Zhou, Q., & Li, J. (2023). Sports-related concussion affects cognitive function in adolescents: A systematic review and meta-analysis. *The American Journal of Sports Medicine*, 51(13), 3604–3618. <https://doi.org/10.1177/03635465221142855>
- Howell, D. R., Osternig, L., Van Donkelaar, P., Mayr, U., & Chou, L.-S. (2013). Effects of concussion on attention and executive function in adolescents. *Medicine & Science in Sports & Exercise*, 45(6), 1030–1037. <https://doi.org/10.1249/MSS.0b013e3182814595>
- Howell, D. R., Wilson, J. C., Kirkwood, M. W., & Grubenhoff, J. A. (2019). Quality of life and symptom burden 1 month after concussion in children and adolescents. *Clinical Pediatrics*, 58(1), 42–49. <https://doi.org/10.1177/0009922818806308>
- Howell, D. R., Zemek, R., Brilliant, A. N., Mannix, R. C., Master, C. L., & Meehan, W. P. (2018). Identifying persistent postconcussion symptom risk in a pediatric sports medicine clinic. *The American Journal of Sports Medicine*, 46(13), 3254–3261. <https://doi.org/10.1177/0363546518796830>
- Jones, K. E., Nyman-Mallis, T. M., Ploetz, D. M., Staples, G., & Benjaminov, A. (2023). Relationship between self-reported symptoms and neuropsychological performance in school-aged children and adolescents with mild traumatic brain injury. *Translational Issues in Psychological Science*, 9(1), 92–101. <https://doi.org/10.1037/tps0000351>
- Koerte, I. K., Schultz, V., Sydnor, V. J., Howell, D. R., Guenette, J. P., Dennis, E., Kochsiek, J., Kaufmann, D., Sollmann, N., Mondello, S., Shenton, M. E., & Lin, A. P. (2020). Sex-related differences in the effects of sports-related concussion: A review. *Journal of Neuroimaging: Official Journal of the American Society of Neuroimaging*, 30(4), 387–409. <https://doi.org/10.1111/jon.12726>
- Kontos, A. P., Braithwaite, R., Dakan, S., & Elbin, R. J. (2014). Computerized neurocognitive testing within 1 week of sport-related concussion: Meta-analytic review and analysis of moderating factors. *Journal of the International Neuropsychological Society: JINS*, 20(3), 324–332. <https://doi.org/10.1017/S1355617713001471>
- Kwan, V., Plourde, V., Yeates, K. O., Noel, M., & Brooks, B. L. (2020). Headache long after pediatric concussion: Presence, intensity, interference, and association with cognition. *Brain Injury*, 34(4), 575–582. <https://doi.org/10.1080/02699052.2020.1725842>
- Lax, I. D., Paniccia, M., Agnihotri, S., Reed, N., Garmaise, E., Azadbakhsh, M., Ng, J., Monette, G., Wiseman-Hakes, C., Taha, T., & Keightley, M. (2015). Developmental and gender influences on executive function following concussion in youth hockey players. *Brain Injury*, 29(12), 1409–1419. <https://doi.org/10.3109/02699052.2015.1043344>
- Ledoux, A. A., Tang, K., Yeates, K. O., Pusic, M. V., Boutis, K., Craig, W. R., Gravel, J., Freedman, S. B., Gagnon, I., Gioia, G. A., Osmond, M. H., & Zemek, R. L. (2019). Natural progression of symptom change and recovery from concussion in a pediatric population. *JAMA Pediatrics*, 173(1), e183820. <https://doi.org/10.1001/jamapediatrics.2018.3820>

- Ledoux, A.-A., Tang, K., Gagnon, I., Osmond, M. H., Yeates, K. O., Healey, K., Gioia, G. A., & Zemek, R. L. (2021). Association between preinjury symptoms and postconcussion symptoms at 4 weeks in youth. *Journal of Head Trauma Rehabilitation*, 37(2), E90–E101. <https://doi.org/10.1097/HTR.0000000000000681>
- Ledoux, A.-A., Webster, R. J., Clarke, A. E., Fell, D. B., Knight, B. D., Cloutier, P., Gray, C., Tuna, M., & Zemek, R. (2022). Risk of mental health problems in children and youths following concussion. *JAMA Network Open*, 5(3), e221235. <https://doi.org/10.1001/jamanetworkopen.2022.1235>
- Loher, S., Fatzer, S. T., & Roebers, C. M. (2014). Executive functions after pediatric mild traumatic brain injury: A prospective short-term longitudinal study. *Applied Neuropsychology: Child*, 3(2), 103–114. <https://doi.org/10.1080/21622965.2012.716752>
- Lumba-Brown, A., Tang, K., Yeates, K. O., & Zemek, R. (2020). Post-concussion symptom burden in children following motor vehicle collisions. *Journal of the American College of Emergency Physicians Open*, 1(5), 938–946. <https://doi.org/10.1002/emp2.12056>
- Mayer, A. R., Stephenson, D. D., Dodd, A. B., Robertson-Benta, C. R., Pabbathi Reddy, S., Shaff, N. A., Yeates, K. O., van der Horn, H. J., Wertz, C. J., Park, G., Oglesbee, S. J., Bedrick, E. J., Campbell, R. A., Phillips, J. P., & Quinn, D. K. (2020). Comparison of methods for classifying persistent post-concussive symptoms in children. *Journal of Neurotrauma*, 37(13), 1504–1511. <https://doi.org/10.1089/neu.2019.6805>
- Mayr, U., Laroux, C., Rolheiser, T., Osternig, L., Chou, L.-S., & Van Donkelaar, P. (2014). Executive dysfunction assessed with a task-switching task following concussion. *PLoS ONE*, 9(3), e91379. <https://doi.org/10.1371/journal.pone.0091379>
- McCrorry, P., Feddermann-Demont, N., Dvořák, J., Cassidy, J. D., McIntosh, A., Vos, P. E., Echemendia, R. J., Meeuwisse, W., & Tarnutzer, A. A. (2017). What is the definition of sports-related concussion: A systematic review. *British Journal of Sports Medicine*, 51(11), 877–887. <https://doi.org/10.1136/bjsports-2016-097393>
- McCrorry, P., Meeuwisse, W., Dvorak, J., Aubry, M., Bailes, J., Broglio, S., Cantu, R. C., Cassidy, D., Echemendia, R. J., Castellani, R. J., Davis, G. A., Ellenbogen, R., Emery, C., Engebretsen, L., Feddermann-Demont, N., Giza, C. C., Guskiewicz, K. M., Herring, S., Iverson, G. L., Johnston, K. M., Kissick, J., Kutcher, J., Leddy, J. J., Maddocks, D., Makkdissi, M., Manley, G. T., McCrea, M., Meehan, W. P., Nagahiro, S., Patricios, J., Putukian, M., Schneider, K. J., Sills, A., Tator, C. H., Turner, M., Vos, P. E. (2017). Consensus statement on concussion in sport—the 5th International Conference on Concussion in Sport held in Berlin, October 2016. *British Journal of Sports Medicine*, 51(11), 838–847. <https://doi.org/10.1136/bjsports-2017-097699>
- McCrorry, P., Meeuwisse, W. H., Aubry, M., Cantu, B., Dvořák, J. D., Echemendia, R. J., Engebretsen, L., Johnston, K., Kutcher, J. S., Raftery, M., Sills, A., Benson, B. W., Davis, G. A., Ellenbogen, R. G., Guskiewicz, K., Herring, S. A., Iverson, G. L., Jordan, B. D., Kissick, J., McCrea, M., McIntosh, A. S., Maddocks, D., Makkdissi, M., Purcell, L., Putukian, M., Schneider, K., Tator, C. H., Turner, M. (2013). Consensus statement on concussion in sport: The 4th International Conference on Concussion in Sport held in Zurich, November 2012. *British Journal of Sports Medicine*, 47(5), 250–258. <https://doi.org/10.1136/bjsports-2013-092313>
- McPherson, A. L., Nagai, T., Webster, K. E., & Hewett, T. E. (2019). Musculoskeletal injury risk after sport-related concussion: A systematic review and meta-analysis. *The American Journal of Sports Medicine*, 47(7), 1754–1762. <https://doi.org/10.1177/0363546518785901>
- Merritt, V. C., Padgett, C. R., & Jak, A. J. (2019). A systematic review of sex differences in concussion outcome: What do we know? *The Clinical Neuropsychologist*, 33(6), 1016–1043. <https://doi.org/10.1080/13854046.2018.1508616>
- Miyake, A., & Friedman, N. P. (2012). The nature and organization of individual differences in executive functions: Four general conclusions. *Current directions in psychological science*, 21(1), 8–14. <https://doi.org/10.1177/0963721411429458>
- Mollayeva, T., Mollayeva, S., Pacheco, N., D'Souza, A., & Colantonio, A. (2019). The course and prognostic factors of cognitive outcomes after traumatic brain injury: A systematic review and meta-analysis. *Neuroscience and Biobehavioral Reviews*, 99, 198–250. <https://doi.org/10.1016/j.neubiorev.2019.01.011>
- Moore, R. D., Hillman, C. H., & Broglio, S. P. (2014). The persistent influence of concussive injuries on cognitive control and neuroelectric function. *Journal of Athletic Training*, 49(1), 24–35. <https://doi.org/10.4085/1062-6050-49.1.01>
- Moore, R. D., Lepine, J., & Ellemberg, D. (2017). The independent influence of concussive and sub-concussive impacts on soccer players' neurophysiological and neuropsychological function. *International Journal of Psychophysiology*, 112, 22–30. <https://doi.org/10.1016/j.ijpsycho.2016.11.011>
- Moore, R. D., Pindus, D. M., Drolette, E. S., Scudder, M. R., Raine, L. B., & Hillman, C. H. (2015). The persistent influence of pediatric concussion on attention and cognitive control during flanker performance. *Biological Psychology*, 109, 93–102. <https://doi.org/10.1016/j.biopsycho.2015.04.008>
- Moore, R. D., Pindus, D. M., Raine, L. B., Drollette, E. S., Scudder, M. R., Ellemberg, D., & Hillman, C. H. (2016). The persistent influence of concussion on attention, executive control and neuroelectric function in preadolescent children. *International Journal of Psychophysiology*, 99, 85–95. <https://doi.org/10.1016/j.ijpsycho.2015.11.010>
- Moore, R. D., Sicard, V., Pindus, D., Raine, L. B., Drollette, E. S., Scudder, M. R., Decker, S., Ellemberg, D., & Hillman, C. H. (2019). A targeted neuropsychological examination of children with a history of sport-related concussion. *Brain Injury*, 33(3), 291–298. <https://doi.org/10.1080/02699052.2018.1546408>
- Novak, Z., Aglipay, M., Barrowman, N., Yeates, K. O., Beauchamp, M. H., Gravel, J., Freedman, S. B., Gagnon, I., Gioia, G., Boutis, K., Burns, E., Ledoux, A. A., Osmond, M. H., & Zemek, R. L. (2016). Association of persistent postconcussion symptoms with pediatric quality of life. *JAMA Pediatrics*, 170(12), e162900. <https://doi.org/10.1001/jamapediatrics.2016.2900>
- O'Brien, H., Minich, N. M., Langevin, L. M., Taylor, H. G., Bigler, E. D., Cohen, D. M., Beauchamp, M. H., Craig, W. R., Doan, Q., & Zemek, R. (2021). Normative and psychometric characteristics of the health and behavior inventory among children with mild orthopedic injury presenting to the emergency department: Implications for assessing postconcussive symptoms using the Child Sport Concussion Assessment Tool 5th Edition (Child SCAT5). *Clinical Journal of Sport Medicine*, 31(5), e221–e228. <https://doi.org/10.1097/JSM.0000000000000943>
- Ozen, L. J., Itier, R. J., Preston, F. F., & Fernandes, M. A. (2013). Long-term working memory deficits after concussion: Electrophysiological evidence. *Brain Injury*, 27(11), 1244–1255. <https://doi.org/10.3109/02699052.2013.804207>
- Ozturk, E. D., Iaccarino, M. A., Hamner, J. W., Aaron, S. E., Hunt, D. L., Meehan, W. P., Howell, D. R., & Tan, C. O. (2021). Executive dysfunction after multiple concussions is not related to cerebrovascular dysfunction. *Physiological Measurement*, 42(9), 095005. <https://doi.org/10.1088/1361-6579/ac2207>
- R Core Team (2022). *R: A language and environment for statistical computing [Computer software]*. R Foundation for Statistical Computing. <http://www.R-project.org/>
- Redlinger, F., Sicard, V., Caron, G., & Ellemberg, D. (2022). Long-term cognitive impairments of sports concussions in college-aged athletes: A meta-analysis. *Translational Journal of the American College of Sports Medicine*, 7(2), e000193. <https://doi.org/10.1249/tjx.0000000000000193>
- Reed, N., Zemek, R., Dawson, J., Ledoux, A.-A., Provvidenza, C., Paniccia, M., Tataryn, Z., Sampson, M., Eady, K., Bourke, T., Dean, S., Seguin, R., Babul, S., Bauman, S., Bayley, M., Beauchamp, M., Carson, J., DePompei, R., Edwards, C., Ellis, M., Esser, M., Fait, P., Fraser, D., Fremont, P., Gagnon, I., Gargaro, J., Gioia, G., Giza, C., Goulet, K., Glang, A., . . . , Yeates, K. O. (2021). *Living guideline for pediatric concussion care*. <https://doi.org/10.17605/OSF.IO/3VWN9>
- Robertson-Benta, C. R., Pabbathi Reddy, S., Stephenson, D. D., Sicard, V., Hergert, D. C., Dodd, A. B., Campbell, R. A., Phillips, J. P., Meier, T. B., Quinn, D. K., & Mayer, A. R. (2023). Cognition and post-concussive symptom status after pediatric mild traumatic brain injury. *Child Neuropsychology: A Journal of Normal and Abnormal Development in Childhood and Adolescence*, 1–18, 1–18. <https://doi.org/10.1080/09297049.2023.2181946>
- Rohling, M. L., Binder, L. M., Demakis, G. J., Larrabee, G. J., Ploetz, D. M., Langhinrichsen-Rohling, J. (2011). A meta-analysis of neuropsychological outcome after mild traumatic brain injury: Re-analyses and reconsiderations of Binder et al., (1997), Frencham et al. (2005), and Pertab et al. (2009). *The*

- Clinical Neuropsychologist*, 25(4), 608–623. <https://doi.org/10.1080/13854046.2011.565076>
- Russell, K., Selci, E., Black, B., Cochrane, K., & Ellis, M. (2019). Academic outcomes following adolescent sport-related concussion or fracture injury: A prospective cohort study. *PLoS One*, 14(4), e0215900. <https://doi.org/10.1371/journal.pone.0215900>
- Russell, K., Selci, E., Chu, S., Fineblit, S., Ritchie, L., & Ellis, M. J. (2017). Longitudinal assessment of health-related quality of life following adolescent sports-related concussion. *Journal of Neurotrauma*, 34(13), 2147–2153. <https://doi.org/10.1089/neu.2016.4704>
- Sady, M. D., Vaughan, C. G., & Gioia, G. A. (2013). Psychometric characteristics of the postconcussion symptom inventory in children and adolescents. *Archives of Clinical Neuropsychology*, 29(4), 348–363. <https://doi.org/10.1093/arclin/acu014>
- Sicard, V., Caron, G., Moore, R. D., & Ellemberg, D. (2021). Post-exercise cognitive testing to assess persisting alterations in athletes with a history of concussion. *Brain Injury*, 35(8), 978–985. <https://doi.org/10.1080/02699052.2021.1944668>
- Sicard, V., Harrison, A. T., & Moore, R. D. (2021). Psycho-affective health, cognition, and neurophysiological functioning following sports-related concussion in symptomatic and asymptomatic athletes, and control athletes. *Scientific Reports*, 11(1), 13838. <https://doi.org/10.1038/s41598-021-93218-4>
- Sicard, V., Hergert, D. C., Pabbathi Reddy, S., Robertson-Benta, C. R., Dodd, A. B., Shaff, N. A., Stephenson, D. D., Yeates, K. O., Cromer, J. A., Campbell, R. A., Phillips, J. P., Sapien, R. E., & Mayer, A. R. (2021). Severity of ongoing post-concussive symptoms as a predictor of cognitive performance following a pediatric mild traumatic brain injury. *Journal of the International Neuropsychological Society*, 27(7), 686–696. <https://doi.org/10.1017/S1355617720001228>
- Sicard, V., Lortie, J.-C., Moore, R. D., & Ellemberg, D. (2020). Cognitive testing and exercise to assess the readiness to return to play after a concussion. *Translational Journal of the American College of Sports Medicine*, 5(11), 1–9. <https://doi.org/10.1249/TJX.000000000000130>
- Sicard, V., Moore, R. D., & Ellemberg, D. (2018). Long-term cognitive outcomes in male and female athletes following sport-related concussions. *International Journal of Psychophysiology*, 132, 3–8. <https://doi.org/10.1016/j.ijpsycho.2018.03.011>
- Sicard, V., Moore, R. D., & Ellemberg, D. (2019). Sensitivity of the cogstate test battery for detecting prolonged cognitive alterations stemming from sport-related concussions. *Clinical Journal of Sport Medicine*, 29(1), 62–68. <https://doi.org/10.1097/JSM.0000000000000492>
- Sicard, V., Stephenson, D. D., Hergert, D. C., Dodd, A. B., Robertson-Benta, C. R., Pabbathi Reddy, S., Yeates, K. O., Cromer, J. A., Meier, T. B., & Campbell, R. A. (2022). Investigating the diagnostic accuracy of a paper-and-pencil and a computerized cognitive test battery for pediatric mild traumatic brain injury. *Neuropsychology*, 36(6), 565–577. <https://doi.org/10.1037/neu0000803>
- Silk, T. J., & Wood, A. G. (2011). Lessons about neurodevelopment from anatomical magnetic resonance imaging. *Journal of Developmental and Behavioral Pediatrics: JDBP*, 32(2), 158–168. <https://doi.org/10.1097/DBP.0b013e318206d58f>
- Silverberg, N. D., Iverson, G. L., Cogan, A., Dams-O'Connor, K., Delmonico, R., Graf, M. J. P., Iaccarino, M. A., Kajankova, M., Kamins, J., McCulloch, K. L., McKinney, G., Nagele, D., Panenka, W. J., Rabinowitz, A. R., Reed, N., Wethe, J. V., Whitehair, V., Anderson, V., Arciniegas, D. B., Bayley, M. T., Bazarian, J. J., Bell, K. R., Broglio, S. P., Cifu, D., Davis, G. A., Dvorak, J., Echemendia, R. J., Gioia, G. A., Giza, C. C., Hinds S. R., Katz, D. I., Kurowski, B. G., Leddy, J. J., Sage, N. L., Lumba-Brown, A., Maas, A. I. R., Manley, G. T., McCrea, M., Menon, D. K., Ponsford, J., Putukian, M., Suskauer, S. J., van der Naalt, J., Walker, W. C., Yeates, K. O., Zafonte, R., Zasler, N. D., Zemek, R. (2023). The American congress of rehabilitation medicine diagnostic criteria for mild traumatic brain injury. *Archives of Physical Medicine and Rehabilitation*, 104(8), 1343–1355. <https://doi.org/10.1016/j.apmr.2023.03.036>
- Teel, E. F., Zemek, R. L., Tang, K., Gioia, G., Vaughan, C., Sady, M., & Gagnon, I. J. (2019). The stability of retrospective pre-injury symptom ratings following pediatric concussion. *Frontiers in Neurology*, 10(JUN), 672. <https://doi.org/10.3389/fneur.2019.00672>
- Ware, A. L., McLarnon, M. J. W., Lapointe, A. P., Brooks, B. L., Bacevice, A., Bangert, B. A., Beauchamp, M. H., Bigler, E. D., Bjornson, B., Cohen, D. M., Craig, W., Doan, Q., Freedman, S. B., Goodyear, B. G., Gravel, J., Mihalov, H. L. K., Minich, N. M., Taylor, H. G., Zemek, R., & Yeates, K. O. (2023). IQ after pediatric concussion. *Pediatrics*, 152(2), e2022060515. <https://doi.org/10.1542/peds.2022-060515>
- Wechsler, D. (2008). *Wechsler adult intelligence scale* (4th edn.). APA PsycTests.
- Wechsler, D. (2014). *Wechsler intelligence scale for children* (4th edn.). Pearson Clinical Assessment.
- Wilke, J., & Groneberg, D. A. (2022). Neurocognitive function and musculoskeletal injury risk in sports: A systematic review. *Journal of Science and Medicine in Sport*, 25(1), 41–45. <https://doi.org/10.1016/j.jsams.2021.07.002>
- Yeates, K. O., Räisänen, A. M., Premji, Z., Debert, C. T., Frémont, P., Hinds, S., Smirl, J. D., Barlow, K., Davis, G. A., Echemendia, R. J., Feddermann-Demont, N., Fuller, C., Gagnon, I., Giza, C. C., Iverson, G. L., Makdissi, M., & Schneider, K. J. (2023). What tests and measures accurately diagnose persisting post-concussive symptoms in children, adolescents and adults following sport-related concussion? A systematic review. *British Journal of Sports Medicine*, 57(12), 780–788. <https://doi.org/10.1136/bjsports-2022-106657>
- Yeates, T. M., Taylor, H. G., Bigler, E. D., Minich, N. M., Tang, K., Cohen, D. M., Bacevice, A., Mihalov, L. K., Bangert, B., Zumberge, N. A., & Yeates, K. O. (2022). Sex differences in the outcomes of mild traumatic brain injury in children presenting to the emergency department. *Journal of Neurotrauma*, 39(1-2), 93–101. <https://doi.org/10.1089/neu.2020.7470>
- Zemek, R., Barrowman, N., Freedman, S. B., Gravel, J., Gagnon, I., McGahern, C., Aglipay, M., Sangha, G., Boutis, K., Beer, D., Craig, W., Burns, E., Farion, K. J., Mikrogianakis, A., Barlow, K., Dubrovsky, A. S., Meeuwisse, W., Gioia, G., Meehan W. P., Beauchamp, M. H., Kamil, Y., Grool, A. M., Hoshizaki, B., Anderson, P., Brooks, B. L., Yeates, K. O., Vassilyadi, M., Klassen, T., Keightley, M., Richer, L., DeMatteo, C., Osmond, M. H. (2016). Clinical risk score for persistent postconcussion symptoms among children with acute concussion in the ED. *Journal of the American Medical Association*, 315(10), 1014–1025. <https://doi.org/10.1001/jama.2016.1203>
- Zemek, R., Osmond, M. H., & Barrowman, N. (2013). Predicting and preventing postconcussive problems in paediatrics (5P) study: Protocol for a prospective multicentre clinical prediction rule derivation study in children with concussion. *BMJ Open*, 3(8), e003550. <https://doi.org/10.1136/bmjopen-2013-003550>