

Low-energy nuclear transitions in subrelativistic laser-generated plasmas

O. RENNER,¹ L. JUHA,¹ J. KRASA,¹ E. KROUSKY,¹ M. PFEIFER,¹ A. VELYHAN,¹ C. GRANJA,² J. JAKUBEK,² V. LINHART,² T. SLAVICEK,² Z. VYKYDAL,² S. POSPISIL,² J. KRAVARIK,³ J. ULLSCHMIED,⁴ A.A. ANDREEV,⁵ T. KÄMPFER,⁶ I. USCHMANN,⁶ AND E. FÖRSTER⁶

¹Institute of Physics of the Academy of Sciences of the Czech Republic, v.v.i., Prague, Czech Republic

²Institute of Experimental and Applied Physics, Czech Technical University, Prague, Czech Republic

³Faculty of Electrical Engineering, Czech Technical University, Prague, Czech Republic

⁴Institute of Plasma Physics of the Academy of Sciences of the Czech Republic, v.v.i., Prague, Czech Republic

⁵Institute of Laser Physics, St. Petersburg, Russia

⁶Institut für Optik und Quantenelektronik, Friedrich-Schiller-Universität, Jena, Germany

(RECEIVED 22 November 2007; ACCEPTED 4 March 2008)

Abstract

The aim of the reported research is to contribute to investigation of new processes and methods interlinking nuclear and laser-plasma physics. With respect to requirements of nuclear experiments at medium-size high-power lasers, the selection of proper candidates for studying the excitation and decay of low-lying nuclear states is reviewed. An experimental approach to the identification of low-energy nuclear transitions is discussed, simple estimates of the ¹⁸¹Ta excitation yield in the laser-generated plasma provide a theoretical basis for planning future work. First tests and results of the experiments at the laser facility PALS are presented.

Keywords: Laser-produced plasma; Low-energy nuclear transitions; Photonuclear excitation; Plasma diagnostics; X- and γ -ray spectroscopy

INTRODUCTION

The possibility to initiate nuclear processes by the action of light quanta had been considered even before the invention of the laser; a survey of the basic concepts and earlier theoretical studies covering the field of photo-induced low-energy nuclear processes can be found in publications (Bohr & Mottelson, 1969; Matinyan, 1998). With the advent of the laser, the theoretical and experimental interest in these phenomena has been renewed despite the fact that theory predicted a very small direct coupling strength of the laser photons to a nuclear system (Matinyan, 1998; Cowan *et al.*, 1999; Beliaev & Arefyev, 1999). The first experiments with low-energy excitation of ²³⁵U (Izawa & Yamanaka, 1979) in a hot dense plasma were performed using a natural uranium target and a modest-parameter CO₂ laser (1 J, 100 ns). Although the interpretation of the obtained results was later questioned, these experiments initiated a detailed investigation of the basic alternative mechanisms

of excitation of low-lying nuclear levels (Harston & Chemin, 1999): direct photoexcitation, inelastic electron scattering, inverse internal electron conversion (IIEC, sometimes called nuclear excitation by electron capture, NEEC), nuclear excitation by electron transition (NEET), and inverse electronic bridge (IEB). The analysis of these processes indicates that in dense plasmas with temperature close to the excitation energy of low-lying nuclear levels, resonance mechanisms (direct photoabsorption, IIEC, and IEB) are the most efficient (Tkalya, 2004). Their schematic diagrams are shown in Figure 1. The yield of the direct photoexcitation is particularly high if the energy required for the nuclear level excitation E_{exc} coincides with the photon energy $h\nu_{\text{pl}}$ of a strong characteristic (bound-bound) line emission of the plasma. The principle of the IIEC is the capture of a proper-energy electron from the plasma continuum at an ionized atomic level (bound-free transition); the energy released in this process excites the nucleus via a virtual photon $h\nu_{\text{b-f}}$. If E_{exc} is close to the energy of the atomic bound-bound transition $h\nu_{\text{b-b}}$, then the channels for the atomic deexcitation are supplemented by the non-radiative mechanism NEET; this process is however rather

Address correspondence and reprint requests to: Oldrich Renner, Institute of Physics of the Academy of Sciences of the Czech Republic, v.v.i., Na Slovance 2, 182 21 Prague 8, Czech Republic. E-mail: renner@fzu.cz

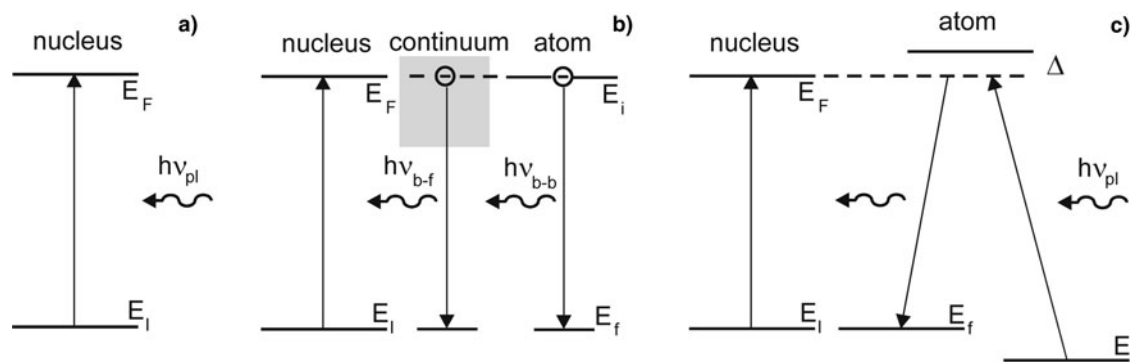

Fig. 1. Resonance mechanisms for excitation of low-lying nuclear states: direct photoabsorption of the thermal plasma radiation (a), inverse internal electronic conversion (b), inverse electronic bridge (c).

rare. The IEB excitation is based on the fact that the widths of the atomic levels are much larger than those of nuclei, thus increasing the width of the working interval of the plasma photons; the transition from the initial state E_i proceeds via the transient state E_n to the final state E_f .

The invention of the chirped pulse amplification (CPA) made it possible to study the laser-matter interactions at intensities above the relativistic limit $I\lambda^2 \approx 10^{18} \text{ Wcm}^{-2}\mu\text{m}^2$ (at these intensities, free electrons quiver with energies larger than those corresponding to their rest mass). The direct laser-radiation excitation of the nuclei is expected at intensities 10^{28} W/cm^2 . The energy transfer accompanying the interactions at energy fluxes $10^{18} - 10^{21} \text{ Wcm}^{-2}$ results in the acceleration of the electrons to energies as large as 10–300 MeV and even into the GeV regime (Malka & Fritzler, 2004; Karmarkar & Pukhov, 2007; Lifschitz *et al.*, 2006; Yin *et al.*, 2006). In most of the experiments, these relativistic electrons convert to γ -rays *via* their deceleration in relatively thick high-Z targets and subsequently initiate photo-nuclear processes, typically (γ, mn) ($m = 1, 2, 3, \dots$), and ($\gamma, \text{fission}$) reactions (Ewald *et al.*, 2003). Alternatively, protons and energetic heavy ions emitted from the primary laser-irradiated targets strike the secondary low- or middle-Z targets inducing further nuclear and even fusion reactions (McKenna *et al.*, 2003; Schwoerer, 2006). This sort of experiments can be performed at large, petawatt laser facilities like the National Ignition Facility at the Lawrence Livermore National Laboratory or VULCAN at the Rutherford Appleton Laboratory (Danson *et al.*, 2005) but also at table-top, short-pulse, high-repetition-rate lasers based on Ti-sapphire technology (Kalachnikov *et al.*, 2001; Nickles *et al.*, 2007; Mangles *et al.*, 2006). Consequently during the last 10 years, the studies of photo-nuclear reactions induced by high-power lasers have become one of the most intensively developing disciplines of the contemporary high-energy-density physics (Ledingham & Norreys, 1999; Ledingham *et al.*, 2003).

The laser-matter interactions at intensities up to $I\lambda^2 \approx 10^{16} - 10^{17} \text{ Wcm}^{-2}$ (i.e., at intensities routinely available either at standard high-repetition lasers, or at medium-size high-power lasers like the Prague Asterix Laser System PALS (Jungwirth *et al.*, 2001, 2005) produce subrelativistic

plasmas with much lower temperature of electrons, typically in the keV energy range (with the hot electron temperature up to 50 keV). However, even these electron energies are sufficient to excite, either directly or indirectly (*via* bremsstrahlung or characteristic X-ray line emission from the hot dense plasma), the low-lying nuclear levels. Despite a relatively good availability of the laser systems capable of providing the requested intensities, the precisely measured data sufficient to verify the nuclear levels structure and the reaction cross sections, to guide the planning of future experiments, and to enable significant advances in a number of areas of science and technology (such as fundamental nuclear physics studies, γ -radiation physics or material research), are rather scarce (Karamian & Carroll, 2002).

The hitherto experiments have been performed both with stable isotopes and nuclear isomers (Irwin & Kim, 1997; Andreev *et al.*, 2000, 2002). In particular, the possibility of exciting the nuclear states in longer-living isomers *via* the action of the laser-produced plasma is extremely attractive. The decay of these isomers through electromagnetic transitions is normally strongly inhibited, therefore the interaction of their levels with externally-introduced photon fluxes provides an important probe of nuclear structure (Carroll, 2004). At the same time, certain isomers can store large amounts of energy for a relatively long time, thus their triggered depopulation (following the laser-induced excitation) can in principle stimulate powerful pulses of γ -rays. The energies of photons required for triggering depend on particular nuclei and deexcitation schemes, they span from units to several hundreds of keV. In general, such photons are routinely produced at laser systems providing intensities above $10^{16} - 10^{17} \text{ Wcm}^{-2}$. Although the proposals to trigger the release of the isomer energy by exciting them to higher levels associated with freely radiating states have been formulated long ago (for a review of this subject, see e.g. Olariu & Olariu (1998)), the attempts to verify this concept are characterized by a considerable controversy.

The recent attempts to reproduce earlier experiments resulted in negative results (Fedosejefs *et al.*, 2005; Gobet *et al.*, 2006), their validity and interpretation is often

doubted. This reflects difficulties generally met in the realization of complex experiments directed at the identification of the laser-induced low-energy nuclear phenomena: (1) selection of the isotopes and nuclear transitions to be studied, modeling of conditions for effective excitation of relevant processes; (2) optimization, production, and handling of the nuclear (especially isomeric) targets; (3) generation of the intense plasma sources tuned with respect to initiation of the studied transitions, complex characterization of nuclei surroundings and competing processes; (4) application of advanced methods and instrumentation for the detection of products accompanying the decay of excited nuclear states, extraction of energy- and time-resolved signals from a high-level background typically met in target chambers; (5) interpretation of the obtained results with respect to underlying theories, comparison of the observed process yields with predictions of quantitative modeling.

The purpose of this paper is to contribute to the optimization of the research directed to a verification of the controversial issues. With respect to a specific character of the nuclear experiments at medium-size high-power lasers (characterized by energies of several hundred joules delivered in subnanosecond pulses to the targets with the active surface area of about 10^{-4} cm², thus creating relatively large volumes of the long-lived hot dense plasmas with an increased probability for observation of the sought phenomena), we review the selection of proper candidates for investigation of excitation and decay of low-lying nuclear states. Making allowance for a current research directed at the search for nuclear excitations in laser-irradiated Ta targets, we present preliminary results and discuss an experimental approach to these studies. Finally we formulate general conclusions and requirements for future research.

CANDIDATES FOR EXCITATION OF LOW-LYING NUCLEAR LEVELS

Systematic selection of nuclei effectively excited by an action of focused laser beams represents a starting point for studies of laser induced nuclear processes. An extensive survey of possible candidate nuclei suitable for photoexcitation using laser-produced plasma photons with energy 1–30 keV has been carried out. Excited nuclear levels decay to the ground or other lower-lying levels primarily by the electromagnetic interaction (typically within 10^{-15} – 10^{-12} s) in the form of emission of a γ -ray or of an internal electron conversion (IEC) (Bohr & Mottelson, 1969). With decreasing transition energy ($E_\gamma \ll 100$ keV), the latter mechanism becomes increasingly dominant. The total decay rate is defined as $\Gamma_T = (1 + \alpha) \times \Gamma_\gamma$, where α is the IEC coefficient. The competition between γ -ray emission and IEC is expressed by the decay branching ratio which depends on the transition energy and multi-polarity (difference in spin and parity) of the levels involved. In addition, similar to the case of nuclear excitation, atomic shell ionization can

strongly affect the relative probability of alternate decay mechanisms and the decay half-life.

The search was carried out throughout the nuclide chart using an extensive database (Sonzogni, 2007) and the detailed up-to-date spectroscopic information (Tuli, 2007). Screening criteria involved primarily the energy and the half-life of the excited nuclear levels (a reliable identification of the decay of the laser-excited levels requires the half-life of de-excitation of the given level to exceed the duration of the laser plasma flash pulse). Other very important parameters, e.g., the effective cross-sections for excitation of given nuclear levels, could not be taken into account because of the lack of the required data. On the other hand, we considered the spin and parity of the levels involved in the potential transition (these parameters determine the transition multi-polarity XL). Electromagnetic transitions of the low multi-polarity were preferred, as the transition probability decreases with increasing transferred angular momentum. We thus decided to restrict our search for electric $E1$ – $E3$ and magnetic $M1$ – $M3$ transitions. An additional criterion was introduced by the basic radiochemical material properties of the prospective targets (Lide, 2003). Fabrication, transport, handling, and cost of the material can severely limit the target choice. Nuclei with low natural abundance and unstable nuclei, namely those with short half-life, may require special production and/or enrichment procedures. Isomers require to be separated not only from other reaction products and near-lying isotopes but also from identical nuclei which are not in the excited (isomeric) state. The large activity of short-lived nuclei can result in a large release of heat and high radiation dose. For example, the interaction chamber and the whole experimental area may be contaminated if even small amounts of highly radioactive material disperse. The handling precautions hold even for normally nonirritating materials like ¹⁸¹Ta; tantalum compounds may cause tumors and its metal dust is a fire and explosion hazard source. Short half-lives complicate accumulation, transport and handling of the target materials.

The search criteria were applied for stable and long-lived unstable nuclei as well as for isomeric nuclei. The different schemes of the excitation and decay of these two groups of nuclei are shown in Figure 2. In stable and long-lived unstable nuclei, the processes of excitation and deexcitation realize between the same ground and excited E^* levels, i.e., the absorbed and emitted transition energies E_i are equal and the delay between their absorption and reemission depends on the lifetime of the excited state. In isomers, the laser-induced excitation does not originate from the ground state but from the long-lived excited level with the energy E^m and lifetime $T_{1/2}^m$. The excitation proceeds *via* the transition energy E_i , the decay of the excited E^* level with the lifetime $T_{1/2}^*$ brings the nucleus either to the ground state or to one of the lower-lying excited states by emitting the energy E_γ , i.e., the energy accumulated in the isomeric state is released. In addition to the decay by γ -ray or IEC

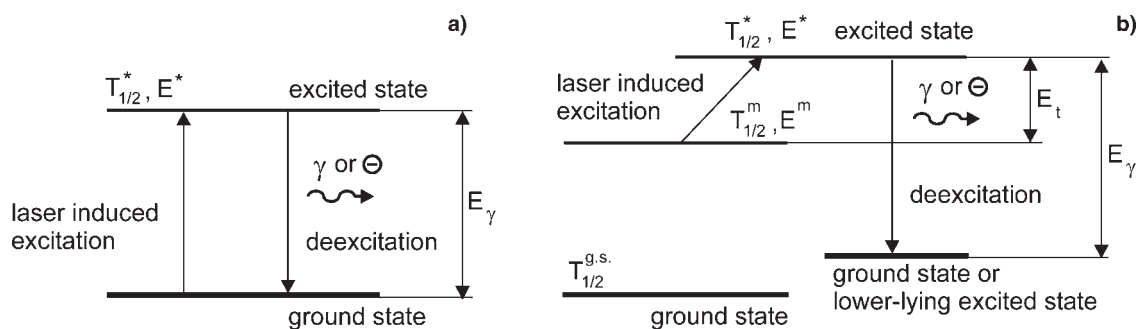

Fig. 2. Excitation and decay in stable and long-lived unstable nuclei (a) and isomers (b).

emission (indicated in Fig. 2), other modes of de-excitation may occur, such as β decay.

The selected results of the search for nuclei with suitable low-lying excited levels are listed in Table 1. The upper part transitions belong to stable and long-lived nuclei, the lower part to isomers with a life-time longer than 20 min. The full list of all prospective candidates for the excitation of low-energy nuclear transitions can be found in Granja *et al.* (2007). Here we only note that with respect to its characteristic properties (nearly 100% isotopic abundance, the transition energy of 6.2 keV, $E1$ multi-polarity, and the relatively long half-life of the laser-excited level above 6 μ s), ^{181}Ta was considered as the first candidate for nuclear studies at the PALS. Explicitness of this selection is partially doubted by narrow radiation ($\Gamma_\gamma = 1.3 \times 10^{-12}$ eV) and total decay ($\Gamma_T = 1.6 \times 10^{-10}$ eV) widths of the 6.2 keV level (Tkalya, 2004) resulting in a rather small resonance photoabsorption cross section $\sigma_\gamma \approx 4.0 \times 10^{-13}$ barn. The only successful observation of the resonance fluorescence in isomeric targets (Andreev *et al.*, 2002) was reported on ^{84m}Rb ; this is the reason why this isomer was included in Table 1. Complicated production *via* irradiation of bromine targets in a cyclotron and a very short half-life however cast doubt on the practical use of this isomer.

The selection of stable and isomer nuclei presented in Table 1 is optimized with respect to typical parameters of the laser-matter interaction at the medium-energy laser facilities, i.e., at systems providing energies of up to 1000 J and subrelativistic intensities of 10^{16} – 10^{17} W/cm². The characteristics of the selected candidates and the feasibility of the

reliable observation of laser-induced gamma emission are envisaged to be tested at the PALS.

EXPERIMENTAL APPROACH TO INVESTIGATION OF LOW-ENERGY NUCLEAR TRANSITIONS

As pointed out in the induction, the hitherto efforts to demonstrate the excitation of low-lying nuclear levels were not too successful: they mostly provided either negative or non-conclusive results. The same situation characterizes the search for excitation and decay of the first isomeric state of ^{181}Ta . The only positive results were reported by Andreev *et al.* (2000) who studied the activation of ^{181}Ta in two experiments with different pico- and femtosecond lasers. The isomer population was estimated through the analysis of the signal detected by a scintillation detector or by a micro-channel plate (MCP) coupled to a CCD camera. In both experiments, the pulses corresponding to the given energy photons were measured as a function of the time after the laser-matter interaction and provided excitation rates which indicate an enormous broadening of the nuclear level widths in the plasma; if confirmed, this result would be of primary importance for prospective energy storage in nuclei. Despite the recently questioned validity of these results (Fedosejefs *et al.*, 2005; Gobet *et al.*, 2006), a relatively large amount of the experimental data (albeit negative) was gathered. With respect to this, the redo experiments with the ^{181}Ta activation provide a proper test bed for checking the experimental strategy and instrumentation used.

Table 1. Selected nuclei for low-energy nuclear excitations

Nucleus	E^m [keV]	$T_{1/2}^m$	E_r [keV]	$T_{1/2}^*$	E_γ [keV]	XL	α
^{45}Sc	—	—	12.4(2)	318(7) ms	12.4(2)	$M2$	632(71)
^{181}Ta	—	—	6.238(20)	6.05(12) μ s	6.238(20)	$E1$	70.5(25)
^{205}Pb	—	1.53×10^7 y	2.329(7)	24.2(4) μ s	2.328(7)	$E2$	4.4×10^8
^{192}Ir	168.14(12)	241(9) y	5.06/9.86	—	—	—	—
^{242}Am	48.60(5)	141(2) y	4.10	—	52.77	$E2$	366.8
^{110}Ag	117.59(5)	249.76(4) d	1.13	36.7(7) ns	117.607	$M3$	168
^{84}Rb	463.62(9)	20.26 min	3.48	9(2) ns	219.0	($M3$)	—

In most of hitherto published data, the nuclear level corresponding to the E1 transition in ^{181}Ta is characterized by a moderate excitation energy of about 6.2 keV, lifetime $\tau_0 \sim 7 \mu\text{s}$ (with complementary level width $\Gamma_T \sim 7 \times 10^{-11} \text{ eV}$), and high internal electron conversion coefficient $\alpha = 70.5$. The uncertainty in the value of the resonance energy 6238 eV stated in Nuclear Data Sheets is about $\pm 20 \text{ eV}$ (Tuli, 2007), reported lifetimes of the excited nuclear state scatter between 6.05 and 9.4 μs (Andreev *et al.*, 2000; Mouchel *et al.*, 1981; Letokhov & Yukov, 1994). The variations in the position, transition energy and lifetime of the excited nuclear level can be attributed to experimental errors, to approximations in theoretical models used, and partly also to the configuration of the atomic electronic shell interlinked with the nucleus level structure. Consequently, an effort to collect reliable data must combine the application of precise experimental methods with the detailed characterization of the excited nuclei and their surrounding. As an example of such approach, we mention the observation of ^{181}Ta excitation at the synchrotron radiation source (Chumakov *et al.*, 1995); using 3.8 μm thick Ta foil, the absolute resonance energy $6214 \pm 2 \text{ eV}$ and 0.53 μs decay time of the nuclear forward scattering were found. A motivation for the research under way at the PALS laser facility is to shed more light on the ^{181}Ta nuclear excitation and decay, to contribute to its univocal identification in the plasma environment, and to apply precise spectroscopic methods for plasma characterization and checking the location of the ^{181}Ta resonance.

Theoretical Estimates of ^{181}Ta Excitation Yield

In comparison with previous experiments, the novelty of the experimental approach adopted at the PALS consists in utilization of a medium-size high power laser capable of delivering 1 kJ laser pulses with the full width half maximum (FWHM) duration $\tau \sim 250 \text{ ps}$ and intensity of up to $7 \times 10^{16} \text{ Wcm}^{-2}$ on the nuclear target. The considerably higher energy and longer duration of the pulse results in creation of larger photon- and particle-emitting plasma volumes and enhanced broadening of the energy levels, thus the probability for observation of the sought transition and the yield increase.

In order to estimate the feasibility and detection limits of the experiment, we start from the general formula describing the reaction yield N (or the number of realized reactions) as

$$N = D \int_{E_t}^{\infty} \sigma(E)I(E)l(E)d(E),$$

where D is the target density, E_t and σ are threshold energy and cross section of the given reaction, $I(E)$ represents the spectrum of photons or particles, and l is the range of projectiles with a given energy. Plasma–nuclear interactions in hot, dense laser plasmas can result in nuclear–photonic and

nuclear–electronic excitations. The process of nuclear excitation to a level E^* by absorption of a photon of energy E_γ can be described (Tkalya, 2004) by the resonant cross section

$$\sigma_\gamma(E_\gamma) = \frac{\pi}{2} g \lambda_\gamma^2 \frac{\Gamma_\gamma \Gamma_T}{(E_\gamma - E^*) + \Gamma_T^2/4},$$

where $\lambda_\gamma = hc/E^*$ is the photon wavelength, Γ_γ is the partial γ -decay width and Γ_T is the total width of the excited level E^* . The statistical factor $g = (2j^* + 1)/(2j + 1)$, where j^* and j are the nuclear spin of the ground and excited levels, respectively. The X-ray photon flux N_γ from a unit area on the surface S of the hot plasma volume is equal to

$$\frac{dN_\gamma}{dt dE_\gamma dS} = \frac{1}{\lambda_\gamma^2} \frac{1}{\exp(E_\gamma/T_e) - 1}.$$

Assuming that the plasma with the electron temperature T_e produced under the action of the high-power laser pulse on the solid target occupies the same volume as the pumped nuclei, then the total number of isomeric nuclei N^* excited during the lifetime τ_p may be approximated by

$$N^* = \frac{dN_\gamma}{dt dE_\gamma dS} \sigma_\gamma n_{i0} S l \approx N_{i0} \frac{\Gamma_\gamma \tau_p}{\exp(E_\gamma/T_e) - 1}.$$

Here n_{i0} is the ion density, N_{i0} is the number of ions in the whole plasma volume $V = Sl$, S being the plasma area on the target surface (approximately equal to the dimension of the laser focal spot) and l its extension along the target normal. To estimate the X-ray emission resulting from the decay of the excited nuclear states, Γ_γ must be replaced by $\Gamma_T/(1 + \alpha)$, where α is the internal conversion coefficient.

For the PALS nominal parameters (1 kJ, 1.315 μm , 250 ps, $7 \times 10^{16} \text{ Wcm}^{-2}$ at the focal spot diameter of 80 μm), the plasma volume created at Ta solid target is about $V = SL$. The plasma scale length $L \sim c_s \tau_p \sim 3 \times 10^{-2} \text{ cm}$ depends on the ion sound velocity $c_s = (ZT_e/m_i)^{1/2} \sim 3 \times 10^7 \text{ cm/s}$. For classical thermal conductivity, the plasma temperature can be estimated using the formula (Zel'dovich & Raizer, 2002) $T_e \sim 0.4(\eta_a I_{16})^{4/9} (\tau/1\text{ps})^{2/9} [\text{keV}] \sim 1 \text{ keV}$, the critical electron plasma density $n_e \sim n_c = 6.5 \times 10^{20} \text{ cm}^{-3}$, and the ion charge can be approximated by the formula (Limpouch *et al.*, 1993) $Z(T_e) \sim 40(T_e/\text{keV})^{0.8} \sim 40$. Using $V = 2.6 \times 10^{-6} \text{ cm}^{-3}$, we obtain $N_{i0} = n_e V/Z \sim 4.2 \times 10^{13}$. For $T_e = 1 \text{ keV}$, $\tau_p \sim 1 \text{ ns}$, and $\Gamma_T \approx 1.8 \times 10^5 \text{ s}^{-1}$ (Andreev *et al.*, 2000), we arrive to $N^* = 1.5 \times 10^7$ excited nuclei. Taking into account $\alpha = 70.5$, the number of activated nuclei decaying via x rays is about 2×10^5 which is a reasonable value with respect to the experiments planned.

It should be emphasized that these estimates of the activated nuclei population in the plasma represent a first-order approximation only. To determine a concentration of the isomeric nuclei rigorously, it is generally desired to simulate the plasma evolution and to treat the absorption of the pumping

x-ray continuum due to the photo-effect in more detail. However, for our conditions, we can neglect this effect because the photon mean free path is about $10\ \mu\text{m}$ for Ta plasma of density $n_e = 10^{21}\ \text{cm}^{-3}$. On the other hand, the uncertainties in the broadening of the nuclear levels in the plasma, internal electron conversion coefficient, etc., may introduce large errors—their more precise evaluation represent one of the key issues in this field of research.

Experimental Setup and Preliminary Results

Previous sections implied that reliable identification of low-energy nuclear transitions in subrelativistic plasmas is a difficult task. To fully benefit from the potential of the medium-size high-power lasers, experiments should be performed under well defined conditions; the use of high-purity targets and the application of advanced instruments and methods for a detailed characterization of the nuclei surrounding, and the monitoring of competing radiative processes is of paramount importance for successful measurements.

A schematic diagram of the experimental setup is shown in Figure 3. The reported experiments were carried out by irradiating massive Ta targets with the frequency-tripled single laser beam of the PALS ($50\text{--}250\ \text{J}$, $0.44\ \mu\text{m}$, $250\ \text{ps}$, $0.4\text{--}2 \times 10^{16}\ \text{Wcm}^{-2}$); the laser characteristics were checked by a routine diagnostic complex (Jungwirth *et al.*, 2001). The plasma emission was observed in two configurations. When measuring the X-ray and γ -emission directly from the plasma created at the Ta surface, the laser radiation was incident normal to the target. An obvious disadvantage of this setup is a variable number of observed emitters due to plasma expansion. To keep their number constant, we tested the second configuration with the ions trapped at a catcher foil. The maximum of the particles is emitted in a direction normal to the target surface, thus the Ta target was tilted by 60° to the laser axis and the material of the plasma plume was collected on a parallel plate of the organic polymer (polyimide, polyethylene, polyamide)

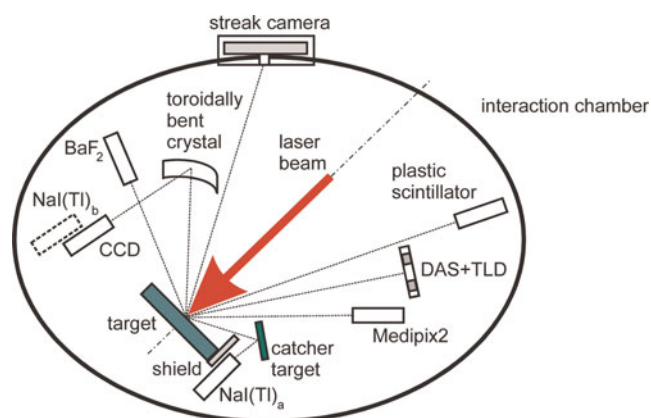

Fig. 3. (Color online) Scheme of the experimental setup.

with the dimensions $30 \times 20 \times 1\ \text{mm}^3$; the target-collector distance was adjusted to $45\ \text{mm}$. Using these catcher targets, the detectors of the nuclear events were fully shielded against the direct view from the primary target. Consequently, more sensitive detectors could be used with respect to the reduced probability of their saturation and damage by strong sub-ns X-ray pulses emitted during the laser-plasma interaction period. The Ta ion implantation, debris deposition and the plate surface alteration due to the strong plasma UV radiation was checked using Nomarski differential interface contrast microscopy and several methods of surface chemical analysis (XRF—radionuclide X-ray fluorescence spectrometry, RBS—Rutherford back-scattering analysis, EMA—electron microprobe analysis, and Raman spectrometry with spatial resolution); these results will be published elsewhere.

The duration (about $1.2\ \text{ns}$) and spatial extent ($200\ \mu\text{m}$) of the strongly emitting Ta plasma were checked by a pinhole camera (with a slit filtered by $1\ \text{mm}$ of Be, $8.5\ \mu\text{m}$ of mylar, and $40\ \text{nm}$ of Al to suppress photon energies smaller than $2.5\ \text{keV}$) coupled to a low-magnification x-ray streak camera with temporal resolution of $3.3\ \text{ps}/\text{pixel}$ and spatial resolution of $2\ \mu\text{m}/\text{pixel}$. The found values are slightly smaller than those corresponding to the PALS nominal parameters at 1ω frequency.

The absolute plasma x-ray emissivity was measured by the toroidally bent crystal spectrometer (TBS) combined with the back-illuminated CCD and by the differential absorption spectrometer (DAS). The TBS equipped with the GaAs (400) crystal bent to the radii $450/305.9\ \text{mm}$ (in meridional/sagittal plane) observed the plasma emission at an angle of 25° to the target normal. The crystal was positioned in a distance of $200\ \text{mm}$ from the plasma source, the CCD camera (PI-MTE, 1300×1340 pixels, pixel size $20 \times 20\ \mu\text{m}^2$) was placed at the Rowland circle in a distance of $316.5\ \text{mm}$ from the dispersive element. The energy window of $250\ \text{eV}$ was centered around the photon energy $6243\ \text{eV}$, the spectra were corrected with respect to the spectrometer transfer function, energy-dependent integrated reflectivity of the crystal and variable transmission of filters and protective foils. The precise alignment of the spectrometer was checked by replacing the Ta target with the Ti foil and observing the overlap with spectral lines Ti He $\zeta\text{-}\iota$ and Ly $\gamma\text{-}\delta$; the corresponding Ti spectrum is shown in Figure 4a. For a given Bragg angle, the integrated reflectivity of the GaAs (400) is by more than two orders of magnitude larger than that of the GaAs (200) which in combination with an additional filtering by the $20\text{-}\mu\text{m}$ -thick Al foil efficiently suppresses the relatively strong Ta line emission at $3\ \text{keV}$. The spectrum synthesized with the code FLYCHK (Chung *et al.*, 2005) for electron temperature $T_e = 1\ \text{keV}$ and density $n_e = 1 \times 10^{21}\ \text{cm}^{-3}$ is shown in Figure 4b. It indicates that close to $6\ \text{keV}$, only continuum is emitted, whereas in the energy range of $2.8\text{--}3.5\ \text{keV}$ intense M-shell transitions of Co-, Ni-, Cu-, Zn-, Ga, and Ge-like Ta ions occur.

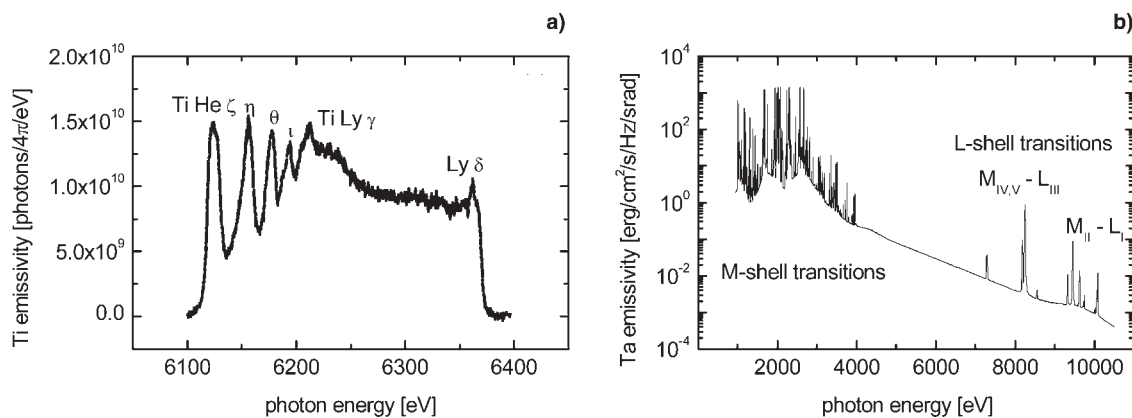

Fig. 4. Emission spectrum of the H- and He-like Ti ions used for calibration of the spectrometer (a) and the Ta spectrum synthesized by the FLYCHK code (b).

The multichannel DAS consisting of a stack of filters (different thickness PMMA, Cr, Mn, Cu, Mo, Ag, and Ta foils) and LiF:Mg, Cu, P thermo-luminescent detectors (TLD-600H, dimensions 3.2 × 3.2 × 0.9 mm³) was employed to measure the X-ray flux in the energy range of 6.01–6.54 keV (using the filter combination Cr 30 μm and Mn 25 μm). The spectrometer was positioned at a distance of 95 cm from the target spot with the viewing axis oriented at 30° to the target normal. The TLDs were calibrated with the 5.9 keV radiation emitted from the ⁵⁵Fe radionuclide and their differential signal was related to the number of incident photons. Thermo-luminescent responses and glow curves were recorded in an N₂ atmosphere using a Harshaw Model 3500 reader and read out at 10 K/s from 320 to 570 K.

The measured emissivity of the Ta plasma in the photon energy range around 6.25 keV is shown in Figure 5. The results obtained with the DAS are up to a factor 3 higher than those measured by the TBS. The observed discrepancy in this data is explained by a non-ideal compensation of the signal transmitted by the Mn and Cr foils at higher photon energies. As expected, at larger laser intensities the fraction

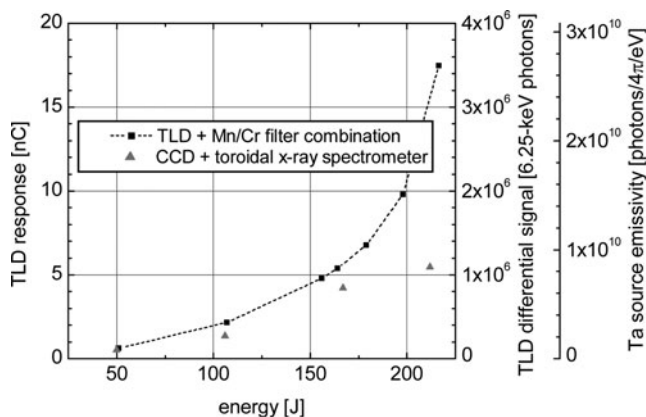

Fig. 5. Absolutely calibrated Ta plasma emissive centered at 6.25 keV. A dashed line connects points measured with the absorption foils method, scatter points were obtained with the crystal spectrometer.

of the high-energy photons and consequently also the discrepancy in signals from both spectrometers increases. At the same laser fluxes of 1.7 × 10¹⁶ Wcm⁻², the Ta emissivity achieved in one shot at the sub-ns laser PALS is by 5 orders of magnitude higher than that measured by Fedosejevs *et al.* (2005) using the 45 fs, 1 mJ, 1 kHz laser system; this comparison characterizes different experimental approaches used.

The prospective decay of the excited nuclear states was searched by several scintillator detectors. The plastic and BaF₂ scintillation crystals in the form of a narrow stick (4 × 8 × 65 mm³) were glued to two fast photo-multipliers (Hamamatsu H5783) operating in a coincidence mode and placed into an Al case with a thin Be window. The signal was read by a LeCroy oscilloscope WavePro7000 (band width 1 GHz, sampling rate 1 GS/s) triggered by a TTL signal from the laser; the duration of the fast signals was shorter than 5 ns. The detectors were calibrated using the ⁵⁵Fe and ²⁴¹Am emitters, the latter one provided photons with the energy ~ 60 keV. The NaI(Tl) scintillator (diameter 25 mm, thickness 1 mm) was protected by the 0.15 mm thick Be window and connected to a bunch of 100 plastic optical fibers. The outgoing signal was amplified using the Hamamatsu H5783 photomultiplier and recorded by the oscilloscope. All scintillators were protected against the parasitic signals by a combination of Al, Cu, and Pb shields. In order to increase the sensitivity and selectivity of the photon detection, the semiconductor single photon counting pixel detector Medipix2 was also tested. This device provides wide dynamic range and almost 100% efficiency for detection of 10 keV photons in essentially noiseless continuous data readout mode (Vykydal *et al.*, 2006), its performance was, however, strongly perturbed by the interfering electromagnetic signals.

An example of the data obtained with the scintillators is presented in Figure 6a. An analysis of the signal detected by the BaF₂ scintillator is obviously limited by a saturation period of 3–5 μs. The detector calibration using the ⁵⁵Fe radionuclide proved that the amplitudes of the signals

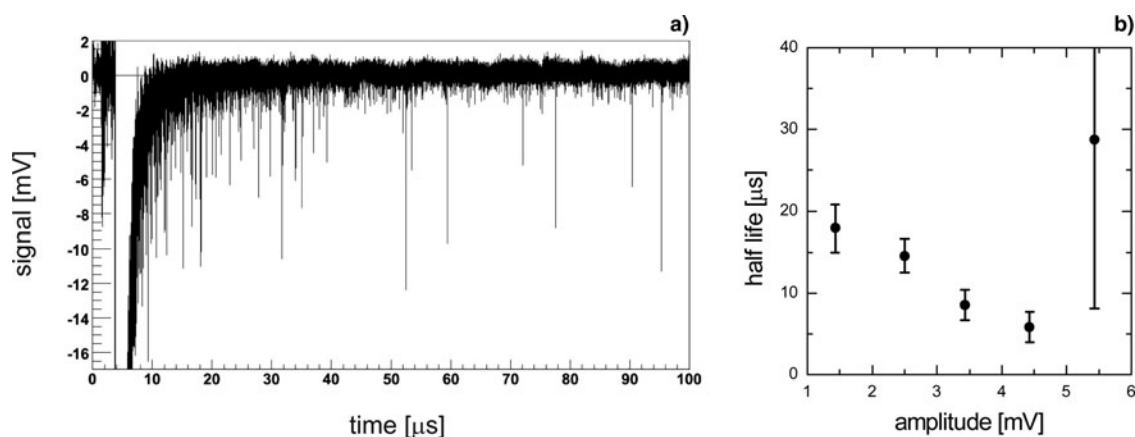

Fig. 6. Analysis of typical signals detected by the BaF₂ scintillator (a) provides ambiguous amplitude dependent alternatives for determination of the decay half-life (b).

corresponding to the decay of nuclei ¹⁸¹Ta are expected on the level of 1–2 mV, this would suggest the existence of the decay with the half-life about 15–20 μs. However, the analysis of the delayed photon emission shows several alternate half-lives for different pulse amplitudes; this unexpected phenomenon does not allow the univocal interpretation of the measured signals. The collection of more complex and reliable data should be a subject of the further research.

CONCLUSIONS AND FUTURE WORK

The purpose of the reported research is to contribute to studies of processes and new methods between nuclear and plasma-laser physics. Although currently limited to the investigation of low-lying nuclear excitations in subrelativistic plasmas, its extension to the region of higher laser intensities (providing, e.g., the possibility to investigate laser-induced transmutations of ¹⁸¹Ta to radioisotopes ¹⁸⁰Ta (Ewald *et al.*, 2003) or even ¹⁸²Ta) in context with the planned upgrade of the Prague laser facility PALS is expected. The experience gathered in experiments using the advanced nuclear instrumentation will contribute to an implementation of these instruments among the standard diagnostic tools.

Future applications of laser-induced nuclear reactions should accent processes which are not covered by classic methods of nuclear physics. They will probably concentrate to phenomena related to particle physics and astrophysics, including advanced tests of quantum electrodynamics. Strong electromagnetic fields and screening effects characteristic for the plasma environment may considerably alter decay half-lives and positions of the nuclear energy levels. Vice versa, spatially dependent detection of nuclear reaction products and studying of the decay characteristics of samples activated inside interaction chambers provide an important diagnostic tool for plasma physicists. Finally, the laser-induced nuclear reactions can find quite practical applications, like a production of protons and short-living isotopes for medical purposes (Ledingham *et al.*, 2003). To conclude,

we are at the very dawn of this new discipline of the high-energy-density physics; its further development may bring many unexpected trends.

ACKNOWLEDGMENTS

This research was performed within the project of the Czech Ministry of Education, Youth, and Sports LC528 and partly funded by the Czech Science Foundation, grant No. 202/06/0697.

REFERENCES

- ANDREEV, A.V., VOLKOV, R.V., GORDIENKO, V.M., DYKHNE, A.M., KALASHNIKOV, M.P., MIKHEEV, P.M., NIKLES, P.V., SAVEL'EV, A.B., TKALYA, E.V., CHALYKH, R.A. & CHUTKO, O.V. (2000). Excitation and decay of low-lying nuclear states in a dense plasma produced by a subpicosecond laser pulse. *J. Exp. Theor. Phys.* **91**, 1163–1175.
- ANDREEV, A.A., VAN'KOV, A.K., PLATONOV, K.YU., ROZHDESTVENSKII, YU.V., CHIZHOV, S.P. & YASHINAL, V.E. (2002). Determination of the radiation cross sections of low-energy transitions of isomeric nuclei from observation of laser-induced γ -fluorescence. *J. Exp. Theor. Phys.* **94**, 862–868.
- BELIAEV, V.S. & AREFYEV, V.I. (1999). Stimulated atomic and nuclear processes in short laser pulse interaction. *Laser Part. Beams* **17**, 361–364.
- BOHR, A. & MOTTELSON, B.R. (1969 and 1975). *Nuclear Structure*, Vol. I and II. New York: W.A. Benjamin Inc.
- CARROLL, J.J. (2004). An experimental perspective on triggering gamma emission from nuclear isomers. *Laser Phys. Lett.* **1**, 275–281.
- CHUMAKOV, A.I., BARON, A.Q.R., ARTHUR, J., RUBY, S.L., BROWN, G.S., SMIRNOV, G.V., VAN BÜRCK, U. & WORTMANN, G. (1995). Nuclear scattering of synchrotron radiation by ¹⁸¹Ta. *Phys. Rev. Lett.* **75**, 549–552.
- CHUNG, H.K., CHEN, M.H., MORGAN, W.L., RALCHENKO, Y. & LEE, R.W. (2005). FLYCHK: Generalized population kinetics and spectral model for rapid spectroscopic analysis for all elements. *High Ener. Density Phys.* **1**, 3–12.
- COWAN, T.E., PERRY, M.D., KEY, M.H., DITMIRE, T.R., HATCHETT, S.P., HENRY, E.A., MOODY, J.D., MORAN, M.J., PENNINGTON,

- D.M., PHILLIPS, T.W., SANGSTER, T.C., SEFCIK, J.A., SINGH, M.S., SNAVELY, R.A., STOYER, M.A., WILKS, S.C., YOUNG, P.E., TAKAHASHI, Y., DONG, B., FOUNTAIN, W., PARNELL, T., JOHNSON, J., HUNT, A.W. & KUHL, T. (1999). High energy electrons, nuclear phenomena and heating in petawatt laser-solid experiments. *Laser Part. Beams* **17**, 773–783.
- DANSON, C. N., BRUMMITT, P.A., CLARKE, R.J., COLLIER, I., FELL, B., FRACKIEWICZ, A.J., HAWKES, S., HERNANDEZ-GOMEZ, C., HOLLIGAN, P., HUTCHINSON, M.H.R., KIDD, A., LESTER, W.J., MUSGRAVE, I.O., NEELY, D., NEVILLE, D.R., NORREYS, P.A., PEPLER, D.A., REASON, C., SHAIKH, W., WINSTONE, T.B., WYATT, R.W.W. & WYBORN, B.E. (2005). Vulcan petawatt: Design, operation and interactions at $5 \times 10^{20} \text{ Wcm}^{-2}$. *Laser Part. Beams* **23**, 87–93.
- EWALD, F., SCHWOERER, H., DÜSTERER, S., SAUERBREY, R., MAGILL, J., GALY, J., SCHENKEL, R., KARSCH, S., HABS, D. & WITTE, K. (2003). Application of relativistic laser plasmas for the study of nuclear reactions. *Plasma Phys. Contr. Fusion* **45**, A83–A91.
- FEDOSEJEVS, R., GOBET, F., DORCHIES, F., FOURMENT, C., HANNACHI, F., ALÉONARD, M.M., CLAVERIE, G., GERBAUX, M., MALKA, G., SCHEURER, J.N., TARISIEN, M., MEOT, V., MOREL, P., LIESFELD, B., ROBSON, L., BLASCO, F., DESCAMPS, D., SCHURTZ, G., NICOLAI, PH. & TIKHONCHUK, V. (2005). Heating of tantalum plasma for studies on activation of 6.238 keV nuclear level of Ta. *Proc. 32nd EPS Conference on Plasma Phys. Tarragona, ECA. 29C*, P–1.152.
- GOBET, F., ALÉONARD, M.M., HANNACHI, F., CLAVERIE, G., GERBAUX, M., MALKA, G., SCHEURER, J.N., TARISIEN, M., BLASCO, F., DORCHIES, F., FEDOSEJEVS, R., FOURMENT, C., SANTOS, J.J., MÉOT, V., MOREL, P., LIESFELD, B., ROBSON, L., HANVEY, S. & DESCAMPS, D. (2006). Search for the 6 keV isomer excitation and decay in a 181Ta plasma produced with a high repetition rate laser. *Proc. 7th AFOSR Workshop on Isomers and Quantum Nucleonics, Dubna.*, 162–170.
- GRANJA, C., KUBA, J., HAIDUK, A. & RENNER, O. (2007). Survey of nuclei for low-energy nuclear excitation in laser-produced plasma. *Nucl. Phys. A* **784**, 1–12.
- HARSTON, M.R. & CHEMIN, J.F. (1999). Mechanisms of nuclear excitation in plasmas. *Phys. Rev.* **C59**, 2462–2473.
- IRWIN, G.M. & KIM, K.H. (1997). Observation of electromagnetic radiation from deexcitation of the ^{229}Th isomer. *Phys. Rev. Lett.* **79**, 990–993.
- IZAWA, Y. & YAMANAKA, C. (1979). Production of $^{235\text{m}}\text{U}$ by nuclear excitation by electron transition in a laser produced uranium plasma. *Phys. Lett. B* **88**, 59–61.
- JUNGWIRTH, K., CEJAROVA, A., JUHA, L., KRALIKOVA, B., KRASA, J., KROUSKY, E., KRUPICKOVA, P., LASKA, L., MASEK, K., MOCEK, T., PFEIFER, M., PRÄG, A., RENNER, O., ROHLENA, K., RUS, B., SKALA, J., STRAKA, P. & ULLSCHMIED, J. (2001). The Prague Asterix Laser System PALS. *Phys. Plasmas* **8**, 2495–2501.
- JUNGWIRTH, K. (2005). Recent highlights of the PALS research program. *Laser Part. Beams* **23**, 177–182.
- KALACHNIKOV, M.P., NICKLES, P.V., SCHÖNNAGEL, H. & SANDNER, W. (2001). On the way to 100 TW – 10 Hz titanium-sapphire laser facilities. *Nucl. Instr. Meth. Phys. Res. A* **472**, 254–259.
- KARAMIAN, S.A. & CARROLL, J.J. (2002). Possibility of combining nuclear level pumping in a plasma with lasing in a solid. *Hyperfine Interactions* **143**, 69–78.
- KARMAKAR, A. & PUKHOV, A. (2007). Collimated attosecond GeV electron bunches from ionization of high-Z material by radially polarized ultra-relativistic laser pulses. *Laser Part. Beams* **25**, 371–377.
- LEDINGHAM, K.W.D. & NORREYS, P.A. (1999). Nuclear physics merely using a light source. *Contemp. Phys.* **40**, 367–383.
- LEDINGHAM, K.W.D., MCKENNA, P. & SINGHAL, R.P. (2003). Applications for nuclear phenomena generated by ultra-intense laser. *Science* **300**, 1107–1111.
- LETOKHOV, V.S. & YUKOV, E.A. (1994). Excitation of isomeric low-lying levels of heavy nuclei in laser-produced plasmas. *Laser Phys.* **4**, 382–386.
- LIDE, D.R. (2003). *Handbook of Chemistry and Physics, 84th Ed.* (Lide, D.R., Ed.). Boca Raton: CRC Press.
- LIFSCHITZ, A.F., FAURE, J., GLINEC, Y., MALKA, V. & MORA, P. (2006). Proposed scheme for compact GeV laser plasma accelerator. *Laser Part. Beams* **24**, 255–259.
- LIMPOUCH, J., ANDREEV, A.A. & SEMAKHIN, A.N. (1993). Conversion of ultrashort laser pulses into x-ray emission in high-density laser plasma. *Proc. SPIE* **1980**, 75–86.
- MALKA, V. & FRITZLER, S. (2004). Electron and proton beams produced by ultra short laser pulses in the relativistic regime. *Laser Part. Beams* **22**, 399–405.
- MANGLES, S.P.D., WALTON, B.R., NAJMUDIN, Z., DANGOR, A.E., KRUSHELNICK, K., MALKA, V., MANCLOSSI, M., LOPES, N., CARIAS, C., MENDES, G. & DORCHIES, F. (2006). Table-top laser-plasma acceleration as an electron radiography source. *Laser Part. Beams* **24**, 185–190.
- MATINYAN, S. (1998). Lasers as a bridge between atomic and nuclear physics. *Phys. Rept.* **298**, 199–249.
- MCKENNA, P., LEDINGHAM, K.W.D., MCCANNY, T., SINGHAL, R.P., SPENCER, I., SANTALA, M.I.K., BEG, F.N., KRUSHELNICK, K., TATARAKIS, M., WEI, M.S., CLARK, E.L., CLARKE, R.J., LANCASTER, K.L., NORREYS, P.A., SPOHR, K., CHAPMAN, R. & ZEPF, M. (2003). Demonstration of fusion-evaporation and direct-interaction nuclear reactions using high-intensity laser-plasma-accelerated ion beams. *Phys. Rev. Lett.* **91**, 075006.
- MOUCHEL, D., NYLANDSTED LARSEN, A. & HANSEN, H.H. (1981). Half-life of the 6.21 keV level in ^{181}Ta . *Z. Phys. A* **300**, 85–88.
- NICKLES, P.V., TER-AVETISYAN, S., SCHNUEERER, M., SOKOLLIK, T., SANDNER, W., SCHREIBER, J., HILSCHER, D., JAHNKE, U., ANDREEV, A. & TIKHONCHUK, V. (2007). Review of ultrafast ion acceleration experiments in laser plasma at Max Born Institute. *Laser Part. Beams* **25**, 347–363.
- OLARIU, S. & OLARIU, A. (1998). Induced emission of γ radiation from isomeric nuclei. *Phys. Rev.* **C58**, 333–336.
- SCHWOERER, H. (2006). *Lasers and Nuclei*. (Schwoerer, H., Magill, J. and Beleites, B., Eds.). Berlin: Springer.
- SONZOGNI, A. (2007). Nuclear structure and decay data. <http://www.nndc.bnl.gov/nudat2/>.
- TKALYA, E.V. (2004). Mechanisms for the excitation of atomic nuclei in hot dense plasma. *Laser Phys.* **14**, 360–377.
- TULI, J. (2007). Nuclear data sheets. <http://www.nndc.bnl.gov/ensdf/>.
- VYKYDAL, Z., JAKUBEK, J. & POSPISIL, S. (2006). USB interface for Medipix2 pixel device enabling energy and position detection of heavy charged particles. *Nucl. Instr. Meth.* **A563**, 112–115.
- YIN, L., ALBRIGHT, B.J., HEGELICH, B.M., & FERNANDEZ, J.C. (2006). GeV laser ion acceleration from ultrathin targets: The laser break-out afterburner. *Laser Part. Beams* **24**, 291–298.
- ZELDOVICH, YA.B. & RAIZER, YU.P. (2002). *Physics of Shock Waves and High Temperature Hydrodynamic Phenomena*. (Hayes, W.D. and Probstein, R.F., Eds.). Mineola, NY: Dover Publications.