

## A comparative study of VR CAD modelling tools for design

Aman Kukreja✉, Christopher Michael Jason Cox, James Gopsill and Chris Snider

University of Bristol, United Kingdom

✉ aman.kukreja@bristol.ac.uk

### Abstract

With recent advancements in Virtual reality (VR), 3D design in VR has gained significant interest from both academia and industries. However, the development of these VR CAD tools is either skewed towards the creative industry or simply mimicking conventional CAD. This paper presents three different tools, analyzes them, and compares their capabilities over various performance parameters. The paper finally suggests where these tools can be used in the design process and some critical pathways for developing VR-based CAD modeling software for practical use in the engineering design industry.

*Keywords: virtual reality (VR), computer-aided design (CAD), engineering design, virtual prototyping*

### 1. Introduction

With the increasing demand for custom-made parts and availability of rapid prototyping technologies, Computer Aided Design (CAD) modelling is no longer a niche for design engineers and modellers. In order to make product development technologies widely accessible to various domains and foster creativity and rapid prototyping of ideas, it is important to have CAD modelling systems that are user-friendly and intuitive (Zou et al., 2023).

Current CAD software provide parametric design, surface design tools, and geometric dimensioning & tolerancing capability, for example. Although extremely useful, CAD software does not have intuitive ideation tools, which can hinder the creativity of novice designers (Ibrahim and Pour Rahimian, 2010). As CAD tools lack immersion and intuitiveness, they struggle to give a real-life feel of observing and creating parts, which ultimately obstructs the intent of the user (Nanjappan et al., 2023). Contrary to modelling using software, creating something with clay or Lego gives creative freedom, ease of use, and efficiency due to its intuitiveness and existence in 3D space (Mathias et al., 2019). A similar sculpting-like tool may help design as intended by simply removing material from the desired places instead of designing through hierarchical steps as in CAD. However, the data output from such sculpting tools may need greater precision and better compatibility with downstream applications, which is a niche for CAD modelling software. Hence, there is a need to research new ways of digital modelling to increase intuitiveness while maintaining the precision and compatibility of CAD software.

Virtual Reality (VR) inherently provides immersive and intuitive interfaces due to its 3D environments and physical interface (Horvat et al., 2022). It has proven beneficial in education and training and is growing its use case in various applications such as complex assembly modelling, interior design (Kim and Hyun, 2022), tourism, etc. In recent years, it has gained significant interest from the design community as the overarching benefits of VR can help solve the above issues related to conventional CAD software. The use of VR enhances spatial awareness and perception during design (Xu et al., 2018) and improves the creativity of the designer (Chang et al., 2022) by providing a holistic view of the parts. The current advancements in VR-based designing software, however, are led by the gaming industry.

This has resulted in the development of software that primarily focuses on the design of unconstrained freeform models, lacking precise geometry definition.

For creating dimensionally accurate prismatic models, the VR-based CAD tools at the moment do not fully capitalise on the intuitive advantage of VR, rather, they focus more on the replication of standard CAD interfaces. Using 2D CAD tools in VR, such as sketch, extrude, trim, revolve, etc., make the process more complicated than conventional CAD (Bourdot et al., 2010; Tran et al., 2022). By not fully incorporating the natural intuitiveness of VR, such advancements risk defeating the point of using VR for CAD modelling. Therefore, we need to determine which tools could give better ergonomic interfaces for creating and editing 3D models. These tools should have higher speed, acceptable accuracy, be easy to use, and provide user satisfaction to design intuitively. Thus, this paper investigates the intuitiveness of VR-based 3D modelling methods, helping to guide the future of VR-CAD development.

The paper continues with a Related Work (Section 2) section that summarises existing VR CAD modelling techniques, and studies that have investigated VR CAD modelling. This is followed by the Methodology section (Section 3), which describes the experimental set-up used to study designers designing using different VR CAD modelling techniques. The results (Section 4) are then presented, followed by a discussion (Section 5) on their significance and the next steps for this research inquiry. The paper then concludes (Section 6) with the key findings from the study.

## 2. Related work

The literature shows several developments both in CAD modelling and applications of VR in the design process.

### 2.1. 3D modelling techniques and their suitability for CAD

3D modelling is common across many sectors, with different approaches typically taken depending on sector needs. In the entertainment industry, the model once created is typically the output, making the appearance created by the model geometry crucial and removing the need, to a degree, for precision. This leads to predominance of surface modelling techniques, and a focus on texturing and render quality. The modelling results in surface geometries and are often actuated through sculpting-like interfaces, with a range of intuitive (Stănculescu et al., 2011) carving and expansion tools that allow sculpting into the desired form. These modelling methods lack precision (Zhang et al., 2005), and lack volumetric information or interior features. Further, as they are constructed from a multitude of polygons with resolution determined by polygon quantity, they can be both large in size and computationally challenging to manipulate. With minimal constraint attached to the surfaces, it is common for the geometry they represent to be incompatible with the cartesian axes of many manufacturing systems, and prohibitively expensive to make.

Separate to these surface methods are those using constructive solid geometries (CSG), in which predefined shapes are combined through union and subtraction operations to create more complex geometries. This approach is also intuitive (Romeiro et al., 2008), but is limited by the subset of predefined shapes used as input, and again is challenged by consequent fabrication of the relatively unconstrained final geometries.

For product design then, while it is highly intuitive and accessible, such surface modelling is not appropriate. For this reason a wealth of research has considered CAD modelling techniques, primarily centred on parametric and NURBS modelling, and constructive solid geometries (CSG). The former is prominent in many packages such as Autodesk Fusion 360, SolidWorks, and Siemens NX and, through parametrising geometries constructed out of constrained sketches, allows control over geometries for fabrication and simplified editing at a later date. While precise, manufacturable, and editable, parametric geometries suffer from complexity in their creation, requiring substantial training effort and a highly hierarchical creation method. The steps to create geometries are not in line with intuitive forms of making, and place emphasis on the designer to alter their creation process to match the approach of the tool.

For the application of CAD modelling in VR, where intuitive spatial interaction is a primary benefit, there is then a need to consider the appropriate form of modelling. Surface and CSG modelling are intuitive, but should not be expected to produce geometries that are compatible with downstream

technical activities. Conversely parametric modelling techniques meet the needs of the engineering toolchain, but do not follow an intuitive process.

## 2.2. VR-based modelling and editing

VR has been used in various stages of the design process. The use of VR in pre-design procedures have been explored by various researchers (Nanjappan et al., 2023; Trump and Shealy, 2023). Trump and Shealy (2023) showed that the use of embodied VR could be beneficial to generate original design ideas. Researchers have also explored various VR-based tools for creating design solutions. Seybold and Mantwill (2021) examined 3D sketching in VR and observed that the same solution quality can be obtained using VR while achieving faster development times. Nandy et al. (2023) investigated the design space across immersive and non-immersive interfaces using pre-designed design elements. They found that 2D interface for modelling enabled users to explore a larger range of designs, whereas VR was more useful in exploring the advantages and disadvantages of single-design solutions. A tangible 3D primitives-based modelling approach named Situated Modelling was created by Lau et al. (2012) that lets users design products using predefined primitives. In this system, virtual models were linked to physical markers and hence it had limited shape and do not have scaling options. Scant work has been done on developing a VR-based CAD modelling system for engineering design. Bourdot et al. (2010) used OpenCASCADE to integrate VR and CAD interfaces and created a new construction history graph (CHG) scheme for generating parametric design. However, it followed steps similar to traditional CAD. Feeman et al. (2018) linked a VR modeler (Autodesk Stingray) with CAD software (Autodesk Fusion 360) using the Application Programming Interface (API). Their software could create dimensionally accurate parts using primitive shapes such as rectangular prisms and spheres and snap-to-grid controls. However, modelling was actuated in the CAD package, with the two-way communication between VR environment and CAD modeller affecting computational performance. Reipschläger and Dachsel (2019) created an integrated augmented reality-based modelling system to combine 2D views with the three-dimensional versions. Despite the recent research and advancement in VR technology, a framework to address critical issues related to CAD modelling is not yet accomplished.

The commercial sector is also showing great interest in developing software for designing products in VR. A benchmarking study to analyse the prominent commercially available software was done by Tran et al. (2022). They concluded that the current software solutions need better ergonomic interfaces for creating and editing 3D models. The design process is not intuitive and seems more complicated than conventional pointer and keyboard-based interactions (Bourdot et al., 2010; Tran et al., 2022). Furthermore, most software can generate only mesh models rather than parametric models that are suitable for further use in downstream applications.

## 2.3. The importance of intuitive tools

Several researchers have explored the importance of using intuitive interfaces during the design process. It lets users design using a mix of skills and is beneficial to make things quickly for ideation purposes. 3D sketching, for instance, enhances creativity by imbuing a sense of space (Keefe et al., 2007). Intuitive interactions in digital sculpting can help create complex models that are otherwise difficult to create (Stănculescu et al., 2011). Alkemade et al. (2017) showed that VR modelling, when coupled with intuitive gesture-based interactions, could help improve the usability and accuracy of the designed models.

Physical modelling methods are often more accessible to a range of users, with humans accustomed to constructing objects and geometries in 3D space, and to representing geometries visually through sketches and drawing. Inspired by physical modelling methods, this paper continues to investigate three geometry creation approaches in VR - namely via 3D sketching, CSG modelling mimicking physical construction kits (i.e. Lego), and voxel-based sculpting mimicking physical sculpting.

The paper considers each method from the perspective of intuitiveness, as well as appropriateness from the perspective to engineering technical toolchains, via exploratory testing of a range of performance parameters. The advantages and applicability of these tools are further evaluated through a focus group session, leading to a set of recommendations on how these VR tools could be used for CAD modelling.

### 3. Methodology

Three methods were identified by considering that the developed system must work intuitively and give efficient editing capability, thus providing value to the design process. These tools were developed in the Unity game engine, an open-source game development engine and one of the two major players in the VR development space with a 29.83% market share (6sense, n.d.). A snapshot of the virtual experiment environment in Unity is shown in Fig. 1 (a), and the tools are explained in Section 3.3.

The methodology to assess these tools is given in Fig. 1(a). A small focus group (3 design researchers with 13 years of average design experience) was tasked with their evaluation of the developed tools. The evaluation was split into two sections: the first was a physical trial of each tool, which involved designing part models. The second was a discussion about the relative capabilities and shortcomings of the different tools, and how they may be applied to the design process.

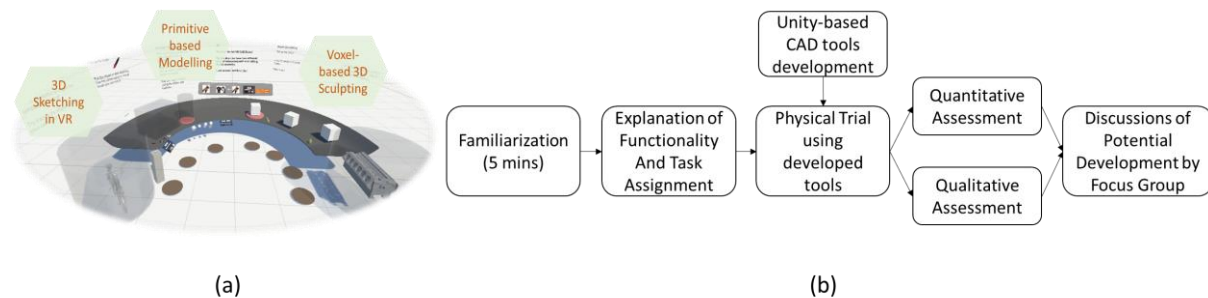

Figure 1. (a) Unity based virtual environment, (b) Methodology of the study

#### 3.1. Key performance indices

There have been several attempts at comparing non-immersive (2D-sketching, 2D assembly, etc.) and immersive ways (3D Sketching, VR-based assembly) of designing with respect to speed (Seybold and Mantwill, 2021), quality, and creativity (Trump and Shealy, 2023). In this work, four interlinking parameters were used to determine the overall usability of a VR tool with respect to intuitiveness. As such, four key performance indices are explained below:

**Speed:** A quantitative index describing how fast a particular method was in designing a part model. It was measured by determining the rate of adding features (Feeman *et al.*, 2018) while designing and was given by the ratio of the total number of created features divided by the total time taken to design the product. The total time was noted till the user was satisfied with their design and then the time was normalized with the total number of features. Here, features are defined as an element of the model (e.g., leg of a chair) or a surface feature (e.g., chamfer, fillet, holes, etc) as shown in Fig. 2. This parameter aggregates the total time for different products and gives an indicator to include the effect of the user's intuition of creating each feature of a product in a certain way with the tool.

**Accuracy:** Defined as the error in the dimensions of the features of the final models created by the participants, compared to the reference dimensions. The models designed by the participants using the three tools were saved and the key dimensions extracted and compared to the reference values to obtain the error not the entire design. The dimensions of the feature of the prefab created using sketching were first determined by converting the 3D sketch into the point cloud data using the vertices taken from the line renderer. Whereas, for models created using 3D sculpting, simply counting the number of voxels gives the exact dimension. The primitive shapes, on the other hand, have implicit dimensions in Unity units (1 Unity unit = 1 m).

**Ease of use:** This index suggests the preferred choice of the tool for users designing a product. This is a qualitative index determined by the user survey on creating the product using a particular method. A user would rank them as per their perception of how comfortable it was to use. For user testing, Participants were presented with a spectrum to mark their interpretation of ease-of-use, ranging from "Easy" at one end to "Not Easy" at the other. These markings were then divided into ten equal divisions and were given scores based on their presence in these grids such that Not Easy represents 0 and Easy represent 9. The scores were aggregated for each tool to give an overall impression of the VR tools.

**User Satisfaction:** This index narrates if the users are able to design as well as they would want. Does the tool give freedom to create as per the user's intent. Hence, a similar ranking scheme was followed as with the Ease of Use KPI, i.e., "Satisfied" at one end to "Not satisfied" at the other end. The participants were tasked with marking the spectrum for both test cases. The scores were then aggregated for each tool and each test model.

Based on these KPIs, it can be asserted that an intuitive tool may only be useful in real design scenarios if it is capable of generating accurate geometry as per the designers intent, in a reasonable time frame while being sufficiently easy to use and learn.

### 3.2. Focus group testing

The performance indices were determined by user testing by three members of the focus group. The members had extensive experience with CAD modelling and familiarity with VR. Every participant was first given 5 minutes to get accustomed to the developed tools and the environment interactions like teleportation and grabbing. They were explained the steps to use various functionalities of the developed tools using hand controllers.

Participants were then tasked with creating two different models: a Chair (Fig. 2 (a)) and a Bracket (Fig. 2 (b)). For each, participants were presented with a dimensioned view of the model to recreate, and instructed to create it at scale. The chair model was taken as it has a clearly distinguishable feature set and a well-articulated design. Therefore, it was a good example to check the speed of design, ease of use, and user satisfaction for specific tools. The bracket was chosen because we wanted to test tools for their ability to create engineering products that are generally prismatic. It, thus, intends to test the accuracy of modelling, control of dimensions, and ease of use with respect to designing engineering models.

The time taken to create each model for each participant was also recorded. The generated models were saved as prefabs after the tests and were analysed to determine the accuracy. After the testing sessions, each tool was discussed by the focus group members who participated in the study, providing a qualitative assessment of their performance. The intuitiveness of the tools, as well as their speed and accuracy was considered. Furthermore, the potential capability of these tools once they are fully realised, and some of the required developments to achieve this, was also discussed.

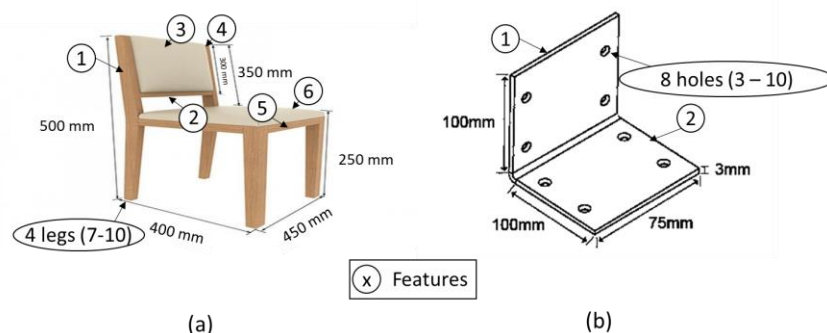

Figure 2. Case studies for user testing

### 3.3. VR-CAD modelling approaches - implementation

This section explains the three modelling tools developed and their implementation.

**3D Sketching in VR:** This tool allowed tracing of the full 3D motion of the hands and lets the user draw in 3D by tracking the VR hand controller and interlinking it with the virtual environment. Programmatically, it instantiates a Line Renderer every time the trigger is pressed to create the line based on the position of the controller. The colour and size of the generated Line can be controlled by setting parameters using a palette provided in the VR environment (Fig. 2). A reference ruler of size 1m was also kept inside the VR environment to assist users in creating dimensionally compliant sketches. The colour and size of the generated line can be controlled by setting parameters using a palette provided in the VR environment (Fig. 3(a)).



**Primitive-Based Modelling:** This method worked on the principle of constructive solid geometry(CSG). Simple primitives (cube, cylinder, plane, sphere) were spawned by the user, either with physics enabled or without (i.e., do not fall, may pass through each other). Primitives could be grasped using the controllers and scaled in each direction via sliders (x, y, z, or all simultaneous) to get the exact dimensions (Fig. 3 (b)). By spawning, scaling, and overlaying primitives, users can build up more complex 3D geometries. The primitive is placed in the scene as a grappable object. The user can hold it and press trigger to instantiate a prefab (linked with the original shape). The transform and scale of the primitives are linked with the slider on the palette that user can manipulate to specify the dimensions.

**Voxel-based 3D Sculpting:** The VR-based sculpting tool developed in this work can carve out material to create part models of desired shapes (Fig. 3(c)). It uses voxels to represent the material and to simulate the removal of material when carved using the sculpting tool (chisel model). The movement of the sculpting tool is one-to-one mapped with the hand controller. As it is moved at specific positions in 3D over the voxel-based raw stock, it is checked for the intersection, and all the intersected voxels are consequently removed, giving the desired shape.

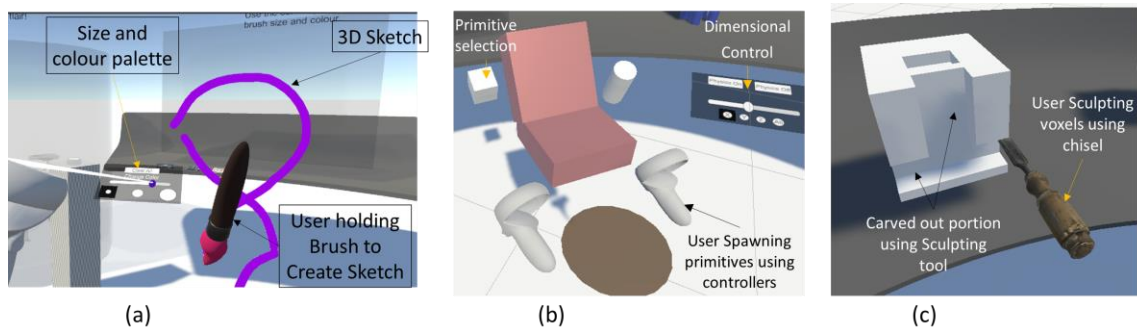

**Figure 3. (a) 3D Sketching in VR, (b) Primitive-Based Modelling, (c) Voxel-based Sculpting**

The conventional CAD software are developed on CAD kernels such as Parasolid, ACIS, etc. Whereas developing such tools in VR is challenging as there is no CAD kernel available for VR development. The tools have to adhere to the available functionalities of Unity. Therefore, simpler User-Interfaces were considered for current implementation and mesh based outputs were produced by each tool.

## 4. Physical testing results

This section presents the results obtained from the user testing of the developed tools. All participants were very familiar with VR interaction, and took less than 5 minutes to familiarize themselves with the developed tools. It was followed by the final testing that included designing the two test models. Fig. 4 (a) shows typical examples of the models created by the participants using our developed methods, and Fig. 4 (b) shows a participant performing the given tasks. The results of the user testing for each KPI are presented one by one below:

**Speed:** Table 1 presents the results, showing the speed averaged for all the participants. For both models, the Primitive-based modelling gave the highest speed. The rate of adding features for 3D sketching was lower than VR-sculpting for case 1 (Chair) and higher for case 2 (Bracket). The time for creating models using 3D sketching showed more variation among participants due to the different levels of complexity with which they designed models.

**Accuracy:** The errors in dimensions of the features for all the participants were averaged out for each tool. Table 1 gives the average error in the dimensions of all the features across both case studies. 3D sketching was least accurate, whereas primitive-based modeller and sculpting gave the comparable accuracy. The standard deviation of errors of Primitive modelling, 3D sculpting, and 3D sketching was found to be 0.42 mm, 1.20 mm, and 1.41 mm respectively, showing that primitives and sculpting consistently performed well for all participants and cases.

For qualitative parameters, the participants were requested to provide their opinion on each, but results should be considered to be indicative relatively rather than precise. Following assessment, these scores were discussed with participants to elucidate issues and opportunities for future development.

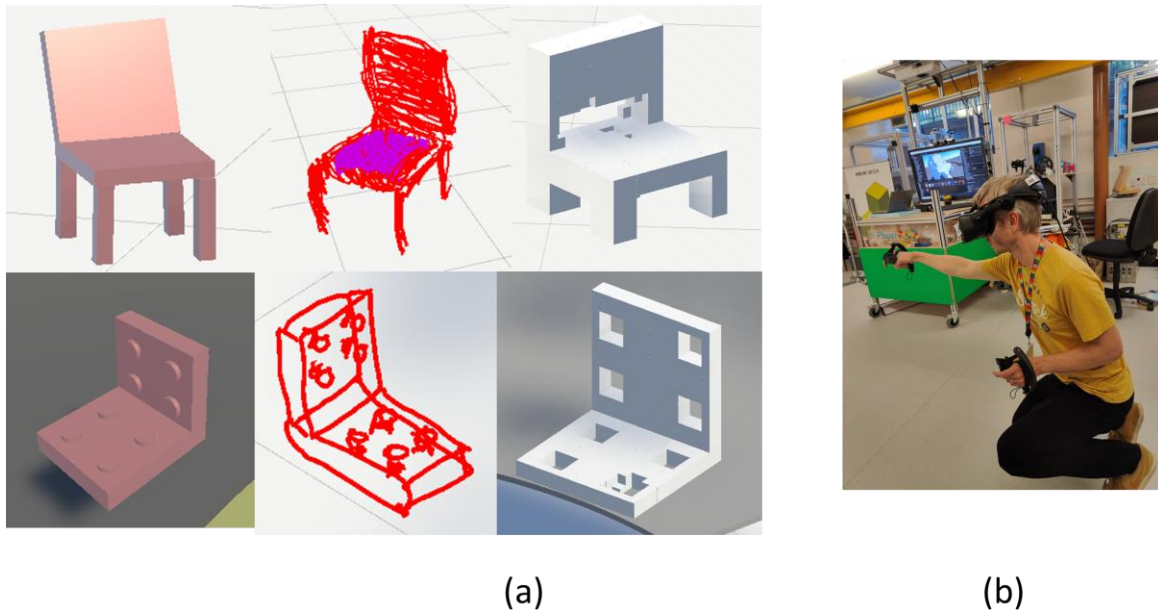

Figure 4. (a) Examples of designed models, (b) Participant creating design in VR

Table 1. Quantitative parameters average values

| Model   | 3D Sketching      | Primitive-Based Modelling | Voxel-based 3D Sculpting |
|---|-------------------|---------------------------|--------------------------|
| Speed (Features per min)                        | 4.0               | 5.6                       | 3.6                      |
| Accuracy (avg. error in mm, Standard Deviation) | 18, $\sigma=1.41$ | 0.9, $\sigma=1.31$        | 1.1, $\sigma=1.20$       |

**Ease-of-use:** The analysis of VR CAD tools for ease of use using point based system defined earlier revealed that the highest-ranked tool was sketching, with a score of 23, followed by voxel-based sculpting, with score of 20, and primitive-based tool ranked the lowest, with a score of 14. These scores of the participants were averaged out and presented on an overall scale in Fig. 5 (a).

**User satisfaction:** As mentioned earlier, this index was used to subjectively test how comfortable the user feels using VR tools to design a particular model. 3D sketching was ranked best with a score of 22, followed by primitive-based modelling with a score of 15, and 3D sculpting ranked lowest with a score of 14. Fig. 5(b) shows the scale representing the perception of the users for satisfaction.

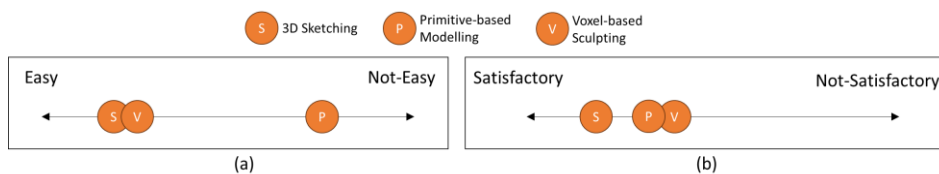

Figure 5. Qualitative parameters: (a) Ease of use, (b) User-satisfaction

#### 4.1. Discussion of physical testing findings

**3D Sketching:** The speed of sketching was primarily affected by the detail level to which feature was created, as the sketching tool facilitated greater detailed design than the other tools, increasing the time spent per feature. It showed the worst dimensional precision, though this was improved through the use of the 1m ruler provided to the participants for reference, as previously observed by Horvat [7]. This was caused by the unconstrained nature of 3D sketching, making it difficult for the participants to precisely control their drawing movements, and maintain accurate line positioning, and the large number of intersecting features (especially in the chair design task). Despite the lack of physical constraint and the low dimensional accuracy, the sketching tool was ranked as both the easiest to use and the most

satisfying. This is probably due to the simple user interface, intuitive design procedure and greater design control of this tool.

**Primitive-Based Modelling:** The primitive-based tool was found to be the fastest for both cases as the size of the components being made were independent of time taken to create them. The accuracy of this tool was the best, as the dimensions could be easily controlled using sliders. However, it was ranked hardest to use, which might be due to the user interface (UI) not being fully optimised for ease of use, or because the user needed to select and scale the correct primitive before adding it to the design environment. It was rated second in terms of satisfaction because the participants thought the distinct features could be easily represented using primitives and with better dimensional control it would be much easier to create the exact shapes using them.

**Voxel-based 3D Sculpting:** The voxel-based sculpting tool was slow to generate features as they had to be carved out entirely. The dimensional accuracy of the features was higher for this tool as the individual voxels could be counted to verify dimensions. This tool was rated almost as highly as the sketching tool in terms of 'Ease of Use' due to the intuitive nature of sculpting, requiring little cognitive effort, and the simple user interface. However the satisfaction of this tool was lowest, as the staircase effect made the possible level of detail dependent on the voxel resolution.

**Limitations of the study:** This paper gives a preliminary study to explore different VR based modelling tools. The study does not evaluate the tools statistically to suggest their use in practical scenarios as it involved low number of users. The developed tools have limited user interaction capabilities. With the rapid development of the VR development tools, the implementation of the modelling tools would be improved and assessed more comprehensively in future.

## 5. Discussion: the future of VR-CAD

The purpose of this work was to investigate VR-based modelling methods, considering intuitiveness and appropriateness for CAD applications. Following the user testing, a focus group session was performed with users to explore capabilities of the methods, and to elicit recommendations for future research and VR CAD tools. The findings of this session are outlined below, split into a discussion about the **Baseline Capabilities** of the tools, the use of **VR design tools in the design process**, the **Intuitiveness, Precision and Compatibility** of the tools. A summary of the advantages, limitations and potential applications of each of the tools, based on the physical testing results and outcomes from the focus session are also presented.

**Baseline Capabilities:** The users observed that 3D sculpting and 3D sketching are intuitive and satisfactory as it was easy to rapidly articulate the ideas into products using these tools. In particular, users can easily create perpendicular faces using 3D Sculpting, whereas, 3D sketching allow creation of organic shapes. Primitive were observed to be better for providing scale perception and to create structures for the final design. However, in the present form of the user interface, these tools are highly dependent on the skill of the designer. The accuracy of the voxel-based sculpting tool can be improved using finer voxels, however, its computational complexity may act as a bottleneck. VR environment gives much larger work space, hence, the ability to see, design, and configure all the parts of a product in one space is viable, which is beneficial for complex assemblies (Eswaran and Bahubalendruni, 2022). It also gives texture and realism that is helpful in observing the design for potential issues.

**VR design tools for Engineering Industry:** The above tools, in their present form, are best suited to the Conceptual Design phase. However, with development into the dimensional precision and compatibility, these tools could also be valuable in the Embodiment and Detailed Design phases. Currently these tools are not in a position to replace traditional CAD tools, but can provide value in augmenting them. For instance, the 3D sketching tool is well suited for creating guide curves, annotations, and rapid generation of ideas for Engineering design reviews. Whereas a Voxel-based sculpting tool can be used for creating near-net and prismatic parts. Primitives are comparatively more familiar for designing models, taking its motivation from CSG modelling. It can be used to create structures and water-tight components with a scale perception. And sculpting can be used to design prismatic parts that can be produced by machining.

**Intuitiveness:** The main benefit of a VR CAD modelling software solution is the natural intuitiveness and immersivity. Based on the study conducted in this paper, it is shown that users are more comfortable



working with tools that align with their natural sense of creation, such as sculpting and sketching. It is thus suggested that the VR-based CAD modelling solution must not aim to resemble conventional CAD software, but instead capitalise on this native advantages. An alternative could be a combination of Voxel, Primitive, and Sketching tools. For example, a base model can be made by intuitively placing primitives at the desired locations, then the main design features can be carved out using sculpting, and finally, the aesthetics can be refined using sketching-based creation of organic shapes.

**Making precise models:** From the above results, it can be inferred that it is challenging to create precise models using intuitive interfaces like in 3D sketching and 3D sculpting. One of the possible directions for the development of VR-CAD could thus be to constrain the direction and movements using triggers and track-pads present on the hand controllers. The constraint movement would give dimensional control, making them suitable for the CAD modelling of engineering components. Future VR-CAD can employ methods to create a parametric modeler using planes as starting objects to define the extent of the features and control their size and locations. Defining planes in VR could be more intuitive and fast. If the above studied methods are linked with these planes, it could enhance dimensional control by inherently adding constraints to the geometry. Such an approach could also support compatibility with fabrication through alignment to the operational axes of manufacturing machines.

**Data Compatibility:** A critical aspect of CAD modelling is the data compatibility. None of the developed methods can output the designed model in the parametric form or neutral CAD file formats such as STEP and IGES. This is a bottleneck in using VR for CAD modelling, as most of the downstream applications of CAD models require standard formats for further processing. Nonetheless, there are well-developed methods for converting voxel-based models into STL or STEP formats (Lorensen and Cline, 1987). Similarly, primitives are also defined by meshes in Unity and hence can also be exported in standard formats. Sketching, however, is the most challenging to parametrize and convert to a standard format. Constraint-based sketching, as explained earlier, could be a solution for addressing the data compatibility issue of sketching in VR-CAD.

## 6. Conclusion

This paper compared three different tools for designing CAD models in VR. The analysis highlighted the apparent strengths and weaknesses of these modelling methods, with primitive-based modelling excelling in speed and accuracy for creating base models, 3D sketching proved intuitive for creating organic features and sculpting for subtractive features. Overall, the study contributes insight into the developed VR tools for designing intuitively, their use into CAD workflows and emphasizes the need for immersive and intuitive interfaces in future VR-CAD software. Finally, it gives a few suggestions for the development of future CAD modelling interfaces for efficiently designing products with respect to three main factors: Intuitiveness, Precision, and Data compatibility.

## Funding statement

The work has been undertaken as part of the Engineering and Physical Sciences Research Council (EPSRC) grants - EP/W024152/1.

## References

- 6sense. (n.d.). “The Game Engine Landscape Report”, 2022, available at: <https://6sense.com/tech/game-development/unity-vs-unrealengine> (accessed 14 November 2023).
- Alkemade, R., Verbeek, F.J. and Lukosch, S.G. (2017), “On the Efficiency of a VR Hand Gesture-Based Interface for 3D Object Manipulations in Conceptual Design”, *International Journal of Human-Computer Interaction*, Vol. 33 No. 11, pp. 882–901, <https://dx.doi.org/10.1080/10447318.2017.1296074>.
- Bourdot, P., Convard, T., Picon, F., Ammi, M., Touraine, D. and Vézien, J.-M. (2010), “VR-CAD integration: Multimodal immersive interaction and advanced haptic paradigms for implicit edition of CAD models”, *Computer-Aided Design*, Elsevier Ltd, Vol. 42 No. 5, pp. 445–461, <https://dx.doi.org/10.1016/j.cad.2008.10.014>.
- Chang, Y., Kao, J.-Y. and Wang, Y.-Y. (2022), “Influences of virtual reality on design creativity and design thinking”, *Thinking Skills and Creativity*, Elsevier Ltd, Vol. 46 No. September, p. 101127, <https://dx.doi.org/10.1016/j.tsc.2022.101127>.

- Eswaran, M. and Bahubalendruni, M.V.A.R. (2022), “Challenges and opportunities on AR/VR technologies for manufacturing systems in the context of industry 4.0: A state of the art review”, *Journal of Manufacturing Systems*, Elsevier Ltd, Vol. 65 No. September, pp. 260–278, <https://dx.doi.org/10.1016/j.jmsy.2022.09.016>.
- Feeman, S.M., Wright, L.B. and Salmon, J.L. (2018), “Exploration and evaluation of CAD modeling in virtual reality”, *Computer-Aided Design and Applications*, Vol. 15 No. 6, pp. 892–904, <https://dx.doi.org/10.1080/16864360.2018.1462570>.
- Horvat, N., Martinec, T., Lukačević, F., Perišić, M.M. and Škec, S. (2022), “The potential of immersive virtual reality for representations in design education”, *Virtual Reality*, Springer London, Vol. 26 No. 3, pp. 1227–1244, <https://dx.doi.org/10.1007/s10055-022-00630-w>.
- Ibrahim, R. and Pour Rahimian, F. (2010), “Comparison of CAD and manual sketching tools for teaching architectural design”, *Automation in Construction*, Elsevier B.V., Vol. 19 No. 8, pp. 978–987, <https://dx.doi.org/10.1016/j.autcon.2010.09.003>.
- Keefe, D.F., Zeleznik, R.C. and Laidlaw, D.H. (2007), “Drawing on Air: Input Techniques for Controlled 3D Line Illustration”, *IEEE Transactions on Visualization and Computer Graphics*, Vol. 13 No. 5, pp. 1067–1081, <https://dx.doi.org/10.1109/TVCG.2007.1060>.
- Kim, H. and Hyun, K.H. (2022), “Understanding Design Experience in Virtual Reality for Interior Design Process”, *Proceedings of the 27th Conference on Computer Aided Architectural Design Research in Asia (CAADRIA) [Volume 1]*, Vol. 1, pp. 59–68, <https://dx.doi.org/10.52842/conf.caadria.2022.1.059>.
- Lau, M., Hirose, M., Ohgawara, A., Mitani, J. and Igarashi, T. (2012), “Situated Modeling: A shape-stamping interface with tangible primitives”, *Proceedings of the 6th International Conference on Tangible, Embedded and Embodied Interaction, TEI 2012*, ACM, New York, NY, USA, pp. 275–282, <https://dx.doi.org/10.1145/2148131.2148190>.
- Lorensen, W.E. and Cline, H.E. (1987), “Marching cubes: A high resolution 3D surface construction algorithm”, *ACM SIGGRAPH Computer Graphics*, Vol. 21 No. 4, pp. 163–169, <https://dx.doi.org/10.1145/37402.37422>.
- Mathias, D., Hicks, B. and Snider, C. (2019), “Hybrid Prototyping: Pure Theory or a Practical Solution to Accelerating Prototyping Tasks?”, *Proceedings of the Design Society: International Conference on Engineering Design*, Vol. 1 No. 1, pp. 759–768, <https://dx.doi.org/10.1017/dsi.2019.80>.
- Nandy, A., Smith, J., Jennings, N., Kuniavsky, M., Hartmann, B. and Goucher-Lambert, K. (2023), “VR OR NOT? INVESTIGATING INTERFACE TYPE AND USER STRATEGIES FOR INTERACTIVE DESIGN SPACE EXPLORATION”, *Proceedings of the Design Society*, Vol. 3, pp. 3851–3860, <https://dx.doi.org/10.1017/pds.2023.386>.
- Nanjappan, V., Uunila, A., Vaulanen, J., Välimaa, J. and Georgiev, G. V. (2023), “EFFECTS OF IMMERSIVE VIRTUAL REALITY IN ENHANCING CREATIVITY”, *Proceedings of the Design Society*, Vol. 3, pp. 1585–1594, <https://dx.doi.org/10.1017/pds.2023.159>.
- Reipschläger, P. and Dachsel, R. (2019), “DesignAR: Immersive 3D-Modeling Combining Augmented Reality with Interactive Displays”, *Proceedings of the 2019 ACM International Conference on Interactive Surfaces and Spaces*, ACM, New York, NY, USA, pp. 29–41, <https://dx.doi.org/10.1145/3343055.3359718>.
- Romeiro, F., Velho, L. and de Figueiredo, L.H. (2008), “Scalable GPU rendering of CSG models”, *Computers & Graphics*, Vol. 32 No. 5, pp. 526–539, <https://dx.doi.org/10.1016/j.cag.2008.06.002>.
- Seybold, C. and Mantwill, F. (2021), “3D sketches in virtual reality and their effect on development times”, *Proceedings of the Design Society*, Vol. 1 No. AUGUST, pp. 1–10, <https://dx.doi.org/10.1017/pds.2021.1>.
- Stănculescu, L., Chaine, R. and Cani, M.-P. (2011), “Freestyle: Sculpting meshes with self-adaptive topology”, *Computers & Graphics*, Vol. 35 No. 3, pp. 614–622, <https://dx.doi.org/10.1016/j.cag.2011.03.033>.
- Tran, T., Foucault, G. and Pinguie, R. (2022), “Benchmarking of 3D Modelling in Virtual Reality”, *Computer-Aided Design and Applications*, Vol. 19 No. 6, pp. 1184–1190, <https://dx.doi.org/10.14733/cadaps.2022.1184-1190>.
- Trump, J. and Shealy, T. (2023), “EFFECTS OF EMBODIED AND SELF-REFLECTED VIRTUAL REALITY ON ENGINEERING STUDENTS’ DESIGN COGNITION ABOUT NATURE”, *Proceedings of the Design Society*, Vol. 3, pp. 1575–1584, <https://dx.doi.org/10.1017/pds.2023.158>.
- Xu, J., Hou, W., Sun, Y. and Lee, Y.S. (2018), “PLSP based layered contour generation from point cloud for additive manufacturing”, *Robotics and Computer-Integrated Manufacturing*, Elsevier Ltd, Vol. 49 No. May 2017, pp. 1–12, <https://dx.doi.org/10.1016/j.rcim.2017.05.006>.
- Zhang, W., Peng, X., Leu, M.C. and Blackmore, D. (2005), “Accuracy and Computational Complexity Analysis of Design Models Created by Virtual Sculpting”, *Computers and Information in Engineering*, ASME/CD, pp. 63–69, <https://dx.doi.org/10.1115/IMECE2005-80506>.
- Zou, N., Gong, Q., Chai, Q. and Chai, C. (2023), “The role of virtual reality technology in conceptual design: positioning, applications, and value”, *Digital Creativity*, Vol. 34 No. 1, pp. 53–77, <https://dx.doi.org/10.1080/14626268.2023.2166080>.