

Double Effect, Triple Effect and the Trolley Problem: Squaring the Circle in Looping Cases

MICHAEL OTSUKA

University College London

In the Trolley Case (Figure 1), as devised by Philippa Foot and modified by Judith Jarvis Thomson, a runaway trolley (i.e. tram) is headed down a main track and will hit and kill five unless you divert it onto a side track, where it will hit and kill one.¹

This side track does not ever reconverge with the main track. In Thomson's version, unlike Foot's, you are not the driver of this trolley. Rather, you are a bystander alongside the tracks who is presented with the opportunity to divert the trolley by pushing a lever. The widespread consensus among moral philosophers who have addressed this problem is that it is permissible to divert the trolley and kill the one rather than do nothing and let the five die. That is also the opinion of the overwhelming majority of internet users who have expressed their views in online polls.²

In the Bridge Case (Figure 2), by contrast, there is no side track onto which to divert the trolley that is headed towards the five. There is just a single track that leads to the five. There is, however, a 'person [who] is on a bridge over the track and cannot move off it. If we move a pole, then it will topple him gently into the [path of the] trolley that is headed toward [the] five people; his being hit will stop that trolley and

This is a revised version of a paper presented at an 'Author Meets Critics' session on Frances Kamm's *Intricate Ethics* (New York, 2006) at the Pacific Division Meeting of the American Philosophical Association in San Francisco in April 2007. It was also presented at the LSE Philosophy Department, the University of Manchester Centre for Political Theory, and as a James Martin Advanced Research Seminar at the University of Oxford, and I thank the members of these audiences for their comments. I'm grateful to Derek Parfit for email correspondences that prompted this paper. I also thank Frances Kamm, Gerald Lang, G. A. Cohen, Horacio Spector and Alex Voorhoeve for their comments.

¹ See Philippa Foot, 'The Problem of Abortion and the Doctrine of the Double Effect', *Oxford Review*, no. 5 (1967), pp. 5–15, and Judith Jarvis Thomson, 'The Trolley Problem', *The Yale Law Journal* 94 (1985), pp. 1395–1415.

² About 77 per cent of the 14,000 people who took an online BBC poll said that one should divert in this case. About 90 per cent of the respondents to Marc Hauser's online Moral Sense Test indicated that it was permissible to divert in this case. See <http://news.bbc.co.uk/1/hi/magazine/4954856.stm> and Marc Hauser, *Moral Minds* (New York, 2006), p. 128.

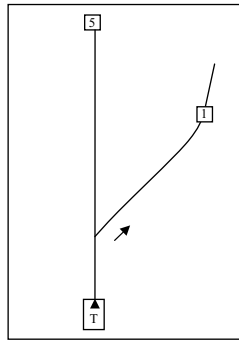

Figure 1. Trolley Case.

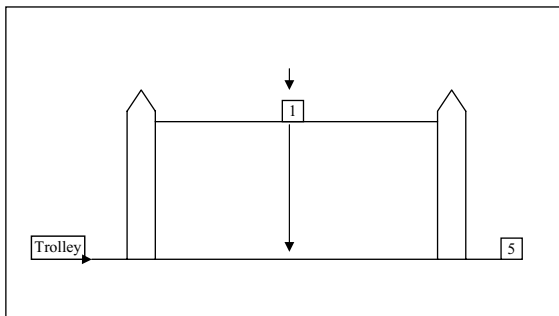

Figure 2. Bridge Case.

kill him’ (p. 143).³ Let us suppose, further, that you would move the pole by pushing a lever on a remote-control device. Here, most intuit that it is *impermissible* to push the lever that topples the person into the path of the trolley.⁴

The trolley problem which I shall address in this article is that of providing a justification for these differing intuitions in the Trolley and the Bridge Cases regarding the permissibility of killing one where this is necessary if five are to be saved from being killed. The Doctrine of Double Effect appears to be tailor-made to provide such a justification. This doctrine prohibits the intending of an evil such as the hitting of an innocent person with a trolley when such evil is intended as a means

³ All such references are to *Intricate Ethics*.

⁴ This is a slight variation on a case of Thomson’s in which the person on the bridge is toppled by a wobbling of the bridge’s handrail. Thomson also entertains a version of the case in which you shove the one off the bridge with your bare hands. (See Thomson, ‘The Trolley Problem’, pp. 1409–10.) About 90 per cent of respondents to Marc Hauser’s online Moral Sense Test deemed such shoving impermissible. (See Hauser, *Moral Minds*, p. 128.)

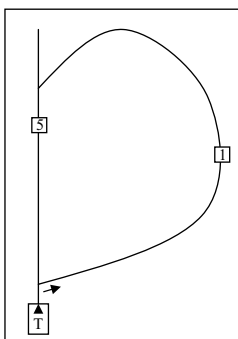

Figure 3. Loop Case.

to bring about a greater good.⁵ You may not act *in order* to bring about an evil. Yet, under certain circumstances, it permits an evil that is a foreseen but unintended consequence of one's bringing about a greater good. In the Bridge Case, you push the lever with the intention of hitting the one. In other words, you do so *in order* to cause the trolley to hit that person. The hitting of the one is intended as a necessary means of stopping the trolley before it hits the five. In the Trolley Case, by contrast, you do not push the lever in order to cause the trolley to hit the one on the side track. Unlike the Bridge Case, the hitting of the one serves no useful purpose in the Trolley Case. You could have saved the five by diverting the trolley onto the side track even if the one had not been there to be hit, and everything else had remained the same. The hitting of the one is merely a foreseen and unintended by-product of the saving of the five. Hence the Doctrine of Double Effect appears to explain why it is impermissible to push the lever in the Bridge Case even though it is permissible to do so in the Trolley Case.⁶

Although this doctrine tracks our intuitions regarding permissibility in these two cases, it is famously vulnerable to powerful counterexample in the form of another case involving a runaway trolley: Thomson's Loop Case (Figure 3). In this case, as in the Trolley Case, if you do nothing, the trolley will travel along a main track and hit and kill the five. Again, as in the Trolley Case, you can divert the trolley onto a side track by pushing a lever. Yet in the Loop Case, unlike the Trolley Case, the side track loops back towards the five on the main track from

⁵ It also prohibits the intending of evil as an end in itself.

⁶ The Doctrine of Double Effect does not permit *any* evil that is merely foreseen. More would need to be said in order to vindicate the claim that the merely foreseen killing of the one in the Trolley Case is permitted by this doctrine. One would need, for example, to establish that the foreseen harm is not out of proportion to the good that the agent realizes.

the other direction. Hence, if there were no obstructions on this side track, diversion would be pointless, as the trolley would continue along the track and loop around and rejoin the main track, whereupon it would hit and kill all five from behind. As it happens, there is a person stuck on the side track who is large enough to prevent the trolley from looping back around. A diverted trolley will come to a halt by hitting and killing him.⁷ If you push the lever in this case, it appears that you would do so in order to cause the trolley to hit the one as a means of saving the five from being killed. Thomson maintains that ‘there is no plausible account of what is involved in, or what is necessary for, the application of the notions “treating a person as a means only,” or “using one to save five,” under which . . . the agent in [the Loop Case] would not be’ doing this.⁸ Such an intentional hitting of the one as a means would be prohibited by the Doctrine of Double Effect. Nevertheless, diverting the trolley strikes most moral philosophers as permissible in the Loop Case.⁹ Thomson draws the lesson from the Loop Case that the fact that you are using someone as a means does not make a difference to moral permissibility, other things being equal.¹⁰ She believes that the Loop Case is one of several considerations that should prompt one to abandon completely the Doctrine of Double Effect.¹¹

In a less radically revisionary attempt to preserve the spirit by amending the letter of the Doctrine of Double Effect, Frances Kamm has argued that reflection upon the Loop Case should prompt a revision rather than a complete abandonment of this doctrine. She has proposed a revision in the form of what she calls the Doctrine of *Triple Effect*.¹² She maintains that this revised doctrine captures the intuition that

⁷ See Thomson, ‘The Trolley Problem’, pp. 1402–3. Given Thomson’s configuration of the tracks in her Loop Case, not only would the five inevitably be hit by the trolley if the one were not present, but the one would inevitably be hit by a trolley if the five were not present. In the absence of the five, the trolley would loop around and hit and kill the one from behind. Michael Costa has argued that the permissibility of turning the trolley onto the one in Thomson’s Loop Case is partially explained by the fact that the one is so-protected by the five. (See Michael Costa, ‘Another Trip on the Trolley’, *The Southern Journal of Philosophy* 24 (1987), pp. 437–49.) We should stipulate, therefore, that in the absence of the five, the trolley would carry on harmlessly down the straight main track past the point at which the looping track reconverges with the main track rather than turning onto that looping track and hitting and killing the one from behind. (See Figure 3, and cf. Kamm’s semi-permeable wall on p. 122 n. 4.)

⁸ Thomson, ‘The Trolley Problem’, p. 1403.

⁹ Or at least this is how it strikes most moral philosophers who have expressed their views in print (or to me in person). Interestingly, however, respondents to Marc Hauser’s online Moral Sense Test split roughly 50–50 regarding the permissibility of diversion in a case that is modelled on Thomson’s Loop Case. (See Hauser, *Moral Minds*, pp. 128–9.)

¹⁰ See Thomson, ‘The Trolley Problem’, p. 1403.

¹¹ Thomson offers further reasons for abandoning the Doctrine of Double Effect in her ‘Self-Defense’, *Philosophy and Public Affairs* 20 (1991), pp. 283–310.

¹² Kamm informs us on p. 129, n. 55, that this apt name is due to Thomas Hurka. Kamm does not offer an unqualified endorsement of the Doctrine of Triple Effect, as she

it is permissible to divert the trolley in the Loop Case by appealing to a distinction between doing something *in order* to bring about an evil and doing something *because* an evil will occur but not in order to bring it about.¹³ Proponents of the Doctrine of Double Effect have overlooked this third category – the third of the triple effects that her doctrine identifies – of doing something because an evil will occur, which is neither (i) that of doing something where one merely foresees that an evil will occur, nor (ii) that of doing something in order to bring about an evil that one intends. The Doctrine of Triple Effect strongly condemns only acts that are performed *in order* to bring about an evil that one intends. It is far more tolerant of acts that are performed because an evil will occur, but not in order to bring that evil about. Since proponents of the Doctrine of Double Effect have overlooked the possibility that one may do something because, but not in order that, an evil occur, they have been inclined to miscategorize these cases as ones in which one does something in order to bring about an evil that one intends.

Some might wonder whether the distinction that Kamm draws between doing something in order to bring about *x* and doing something merely because *x* will occur is a distinction without a difference. I am, however, convinced that Kamm has shown that there is a genuine difference between the two, as is revealed by the following case of hers:

I intend to give a party in order for me and my friends to have fun. However, I foresee that this will leave a big mess, and I do not want to have a party if I will be left to clean it up. I also foresee a further effect of the party: If my friends have fun, they will feel indebted to me and help me clean up. I assume that a feeling of indebtedness is something of a negative for a person to have. I give the party because I believe that my friends will feel indebted and (so) because I will not have a mess to clean up. These expectations are [necessary] conditions of my action. I would not act unless I had them. The fact that they will feel indebted is a reason for my acting. But I do not give the party even in part in order to make my friends feel indebted nor in order to not have a mess. (p. 95)

Applying her Doctrine of Triple Effect to cases involving runaway trolleys, Kamm maintains that, in the Bridge Case, you *impermissibly* push the lever *in order* to cause the trolley to hit the person. She maintains that, in the Loop Case, by contrast, you do not divert the trolley in order to hit the one. Rather, you *permissibly* divert the trolley *merely because* it will hit that person. Your primary intention in this case is that the trolley not hit the five at all. Because you intend that the

raises a number of problems for it on pp. 132–8. These problems do not bear on the cases under discussion in this article.

¹³ See p. 92. This distinction will be explained and illustrated in the main text below.

trolley not hit the five at all, you intend the elimination of the problem of the trolley's hitting the five after travelling down the main track. This intention is realized by your pushing the lever that diverts the trolley down the looping track, as this eliminates the just-described problem. It also creates a *new* problem: that of the trolley's looping around and hitting the five from behind. You need not, however, intend that the trolley hit the one on this looping track. Rather, you divert the trolley because you realize that the new problem you create by such diversion – that of the trolley's hitting the five from behind after looping around – will be eliminated by its hitting the one. You divert the trolley onto the looping track because it will hit the one but not in order to hit the one.¹⁴

While I grant both the coherence and the moral significance of Kamm's distinction between doing something in order to bring about *x* and doing something merely because *x* will occur, I nevertheless reject her appeal to this distinction to explain the permissibility of turning the trolley in the Loop Case. This is because I am unconvinced by her denial that you would push the lever in order to get the trolley to hit the one in this case. In Section I, I shall argue, contrary to Kamm, that one who diverts the trolley in the Loop Case does so in order to hit the one as a means of saving the five. In Section II, I shall argue that we have good theoretical grounds for maintaining that such diversion is impermissible, where these grounds are sufficient to override our case-based intuition that it is permissible.

I

Let us consider the following grounds that Kamm offers for denying that you push the lever in the Loop Case in order to hit the one:

*If we intend to bring *x* about, we pursue *x*. That is, if one way fails to produce *x*, we adopt another way.* But if we act [in the Loop Case] because we notice that our doing only what needs to be done in order to stop the trolley from hitting the five from the front will thereby also cause the one to be hit, we need not, as rational agents, be committed to hitting the one by other means if the hitting fails to come about. For example, suppose the redirected trolley would jump over the one person on the track. We need not be committed to giving the trolley an extra push that is unnecessary to get it away from hitting the five from the front but necessary to get it to hit the one person, where hitting the person is what is causally necessary to prevent the jump over him (Extra Push Case) . . . [Figure 4]

Why would someone who redirects the trolley not be committed to doing these things? Here is a possible explanation: In redirecting the trolley, the agent merely foresees that an act he must undertake to stop the threat from coming from the front will cause a hitting that stops the threat from returning around the back. If he gives the extra push in the Extra Push Case as described,

¹⁴ See pp. 118 and 136–7.

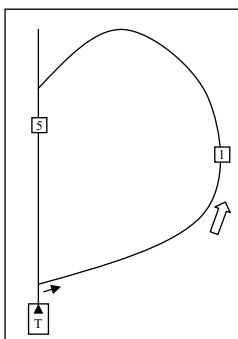

Figure 4. Extra Push Case.

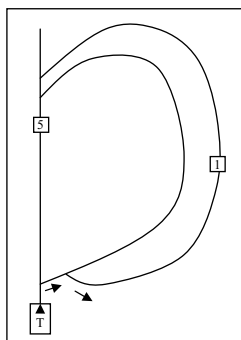

Figure 5. Two Loop Case.

he will do something that is undertaken especially to accomplish the hitting that is not necessary for stopping the threat from coming from the front. Doing something extra in this case would certainly involve intending the hitting. (p. 97)

Kamm's description of the intention of the agent in the Extra Push Case seems accurate. But note what Kamm goes on to say:

In other cases . . . , undertaking an extra act to save the five would not indicate an intention to hit the one, even if hitting the one is a means (i.e., what we must do) to save the five. Consider the Two Loop Case. [Figure 5] Suppose that after being redirected from its initial hit, the trolley will go around a looping track toward the five, unless it is redirected again – by an extra push not needed to get it away from its initial hit. If it is redirected again, it will go onto a track that loops to the five too but on which a person sits. The person will be hit and this will stop the trolley. Nothing I have said about the extra push in the Extra Push Case implies that someone opposed to intending the hit may not give the extra push in the Two Loop Case. For in the latter case, the extra push is just like the first redirection in the regular Loop Case: We redirect the trolley again

to save the five from the second way in which it would hit them, but we do this only because the one will be hit and stop any further looping. (pp. 97–8)

I do not think Kamm can defensibly differentiate the extra pusher's intention in the Two Loop Case from his intention in the Extra Push Case. In both cases the agent first diverts the trolley from the main track and onto a looping track in order to get it away from hitting the five via the main track. On Kamm's account, the agent proceeds to give the trolley an extra push in the Two Loop Case in order to get it away from the path it would otherwise travel, as it will loop back and hit the five via this path if he does not give the extra push. Now it appears that in the Extra Push Case the agent could be moved to give the trolley an extra push for the very same reason: in order to get the trolley away from the path it would otherwise travel, as it will loop back (after jumping over the one) and hit the five via this path if he does not give the extra push. Kamm maintains, however, that, in the Extra Push Case, the agent would give the extra push in order 'to accomplish the hitting [of the one] that is not necessary for stopping the threat from coming from the front'. Note that the extra push is not necessary to stop the threat from coming from the front in the Two Loop Case either. Why then does Kamm not describe the extra push in the same terms in the Two Loop Case – i.e. in order to accomplish the hitting of the one?

In the Two Loop Case, it is clear that hitting the one is not causally necessary to get the trolley away from the first path that loops back towards the five. Here the extra push onto the second looping track is in itself causally sufficient, independently of the hitting of the one, to get the trolley away from the first path that loops back towards the five. Might the hitting of the one in the Extra Push Case, by contrast, be causally necessary to get the trolley away from the first path that loops back towards the five? If there were such a contrast between the two cases, that might ground the difference in the extra pusher's intention that Kamm describes. I shall show, however, that there is no such contrast.

On Kamm's description of the Extra Push Case, 'hitting the person is what is causally necessary to prevent the jump over him'. I assume that what Kamm has in mind is that giving the trolley an extra push as it begins to take flight will cause it to move forward into the one rather than upward over him, and its collision with him will prevent the trolley from clearing him. It does not follow, however, from the fact that such hitting of the one is causally necessary to prevent the trolley from jumping over him that hitting him is also causally necessary to get the trolley away from the first path that loops back towards the five (after the trolley jumps over him). An inspection of the mechanics of the Extra Push Case reveals that, as in the Two Loop Case, giving the trolley an extra push is in itself sufficient, independently of its hitting

the one, to get the trolley onto a different path from the one it would otherwise have travelled. In the Two Loop Case, that different path begins, prior to the hitting of the one, at the point at which the trolley diverges along the second looping track. In the Extra Push Case, that different path begins, prior to the hitting of the one, at the point at which the extra push begins to alter the trajectory of the trolley. The trolley in the Extra Push Case must begin to travel this different path prior to the hitting of the one, given that the agent is acting on the trolley that would otherwise jump over the one and not acting on the one by moving him. In other words, the agent moves the trolley into the one rather than the one into the trolley.

Recall that Kamm maintains that giving the extra push in the Extra Push Case ‘would certainly involve intending the hitting’ of the one. She is right about this. Moreover, we have uncovered no good grounds to differentiate the extra pusher’s intention in the Two Loop Case from his intention in the Extra Push Case. If, as I believe, this is because there are no good grounds, it follows that an agent’s giving the extra push to divert the trolley onto the second looping track in the Two Loop Case would also certainly involve an intention to hit the one. The agent would give the extra push *in order* to make the trolley hit the one and not only because it will hit the one.

I would maintain that in both the Two Loop Case and Thomson’s original Loop Case, it is a mistake for Kamm to deny that you divert the trolley onto another track in order to make it come to a halt by hitting the one. This is a mistake because, when we abstract from the fact that it would come to a halt by hitting the one, you do not eliminate or lessen the threat that the trolley poses to the five by sending it down a looping track.¹⁵ The trolley poses just as grave a threat to the five whether it is coming towards them via the main track or via a looping track. Hence, you have no reason to divert the trolley down a particular looping track except in order to eliminate the threat it poses to the five by making it come to a halt by hitting the one. Its diversion down a looping track is valuable merely as a means to make it come to such a halt.

We can usefully contrast these looping cases with the following case. In this contrasting case, as in the original Trolley Case, the track onto which you can divert the trolley does not reconverge with the main track. Let us suppose, moreover, that if you divert the trolley onto this

¹⁵ I would say the same thing about Kamm’s Wagon Case in which, if the trolley is diverted onto the looping side track, it comes to a halt but depresses a button that starts up a wagon on that same track that proceeds to head towards the five yet is stopped before it gets to the five because it hits the one (see p. 94). When we abstract from the fact that the wagon will come to a halt by hitting the one, here, as in the Loop Case, you do not eliminate or lessen the threat that the trolley poses to the five by diverting it, even though in this case the trolley poses its equally grave threat by causing the wagon to start up.

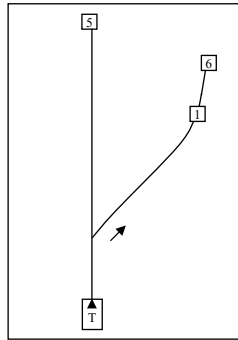

Figure 6. Six Behind One Case.

side track, then it will lethally hit one person on this track and this collision will cause the trolley to come to a halt. Furthermore, and unlike the original Trolley Case, if the one had not been there, then the trolley would have carried on, gathering speed, and hit and killed six people further down this side track. (I shall call this the Six Behind One Case. (Figure 6).) Unlike the looping cases, and as in the original Trolley Case, here the *diversion* of the trolley completely eliminates the threat of the trolley to the five on the main track, where this elimination is irrespective of the fact that the trolley will hit the one. The hitting of the one is therefore in no way a means to saving the five. But unlike the original Trolley Case, and like the looping cases, the fact that the trolley will hit the one is a necessary condition of action – you would not have diverted the trolley if the one had not been there to stop it and the trolley would have carried on and hit and killed the six on this side track.

If you divert the trolley onto the side track in this Six Behind One Case, must you do so in order to hit the one? Hitting the one could not serve your goal of saving the five on the main track. Rather, it could serve only the goal of preventing the six behind him from being killed. Therefore, to say that you divert the trolley in order to hit the one would be tantamount to saying that you divert the trolley in service of your goal of preventing the bad consequences of this diversion that would have ensued if the one had not been there to shield the six from being killed. That would be an odd thing to say, as one does not do something in order to mitigate the bad consequences of the doing of that very thing.¹⁶ So you do not divert the trolley in order to hit the one in the Six Behind One Case. Rather, you divert the trolley only in order to save

¹⁶ Similarly, in Kamm's Party Case described above, you do not throw the party in order to get your guests to clean up afterwards, since one does not do something in order to mitigate the bad consequences of the doing of that very thing.

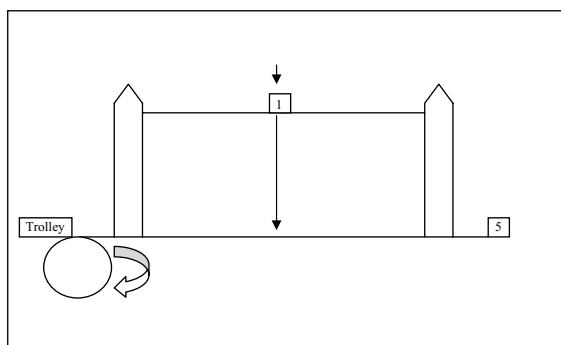

Figure 7. Loop-Bridge Case.

the five. That is your goal, and, as I have noted above, it is completely realized by such diversion and in no way served by hitting the one. You divert the trolley, not in order to, but rather merely because it will, hit the one, thereby coming to a halt before it would cause an even greater catastrophe by hitting the six further down the track.¹⁷

Intuitively, it is permissible to divert the trolley in this Six Behind One Case. Moreover, Kamm's Doctrine of Triple Effect properly distinguishes the permissible Six Behind One Case from the impermissible Bridge Case. Her doctrine fails, by contrast, to distinguish looping cases from the Bridge Case. This is because in both looping cases and the Bridge Case, and unlike the Six Behind One Case, you act in order to get the trolley to hit the one, as this serves your goal of saving the five. You do not act merely because it will hit the one.

Kamm's attempt to justify the turning of the trolley in looping cases is further undermined by the following case that I shall call the Loop-Bridge Case (Figure 7). Here your pushing a lever causes the trolley to be diverted onto a perfectly circular track that loops back around to the same point where the trolley was on the main track before it was diverted, whereupon it proceeds in the direction of the five after this brief circular detour.¹⁸ Let us suppose, further, that the trolley's

¹⁷ One might insist that your primary goal is really to minimize the number of people who will be killed rather than to save the five on the main track. Moreover, it is arguable that you hit the one in order to, rather than merely because you will thereby, minimize the number of people who are killed. My reply to this challenge is that your primary goal need not be that of minimizing the number who will be killed. Rather, your primary goal might be that of saving the five who are imperilled by the trolley, where this goal is constrained in so far as you would abandon it if there were grounds sufficient to condemn what you would need to do in order to save the five. If you are a non-consequentialist, such grounds will not be exhausted by considerations of numbers alone. For if they were, then you would not hesitate to kill the one in the Bridge Case.

¹⁸ This aspect of the case is inspired by Kamm. See p. 124 n. 9.

travelling in this circle remotely triggers the pole on the bridge over the main track to move as in the Bridge Case, thereby causing the person on the bridge to fall onto the main track and into the path of the trolley after it has circled around the side track and resumed its travel down the main track. His being hit will stop the trolley and kill him.¹⁹

Kamm is committed to the permissibility of diverting the trolley in the Loop-Bridge Case, since this case would strike her as relevantly analogous to Thomson's Loop Case. She offers the following commentary on the Loop Case:

The trolley need not even be coming from a different direction for there to be a new problem. We could imagine a Loop Case in which the diversion results in the trolley going in a perfect circle right back to where it was originally . . . and then heading toward the five. I still believe that it is proper to see the trolley's coming back [after circling] . . . as a second problem that arises from what we did to take care of the first problem. (p. 124 n. 9)

By a parity of the reasoning that she applies to Thomson's Loop Case, Kamm would say that you divert the trolley in the Loop-Bridge Case in order to eliminate the initial problem the trolley poses to the five. Having diverted the trolley, you now face the allegedly new problem of the trolley's hurtling towards the five after circling. But you realize that this new problem will be solved by the person's falling from the bridge and stopping the trolley before it hits the five. You do not push the lever in order that the trolley hit the one. Rather you push the lever only because it will hit the one. Hence Kamm would maintain that her Doctrine of Triple Effect renders diversion permissible in the Loop-Bridge Case as well as the Loop Case.

There is one important respect in which the Loop-Bridge Case differs from the Loop Case: you move the person into the path of the trolley in the Loop-Bridge Case, whereas you move the trolley into the path of the person in the Loop Case. Some might maintain that whether you move a person into a threat or move a threat into a person makes a difference to permissibility in this context. Kamm, however, has persuasively argued against the moral significance of this distinction in the relevantly similar context of a Lazy Susan Case (Figure 8). In this

¹⁹ This aspect of the case is inspired by the following case of Derek Parfit's that he has presented in correspondence. You can divert the trolley onto a track that loops around and back towards the five from the other direction just as in Thomson's Loop Case which I describe in the main text above. But, unlike Thomson's version, there is not already someone stuck on the looping track. Rather, as the trolley travels down the looping track it hits and depresses a lever, which causes someone to fall from a bridge and onto the looping track in front of the train, thereby causing the train to come to a halt by hitting that person. The novelty of Parfit's case that I exploit is that the movement of the already diverted trolley is among the causes of the person's falling from the bridge. Parfit reports that Kamm has affirmed the permissibility of such diversion in conversation.

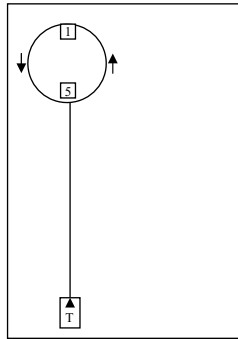

Figure 8. Lazy Susan Case.

case, the only way to save five from being hit by a trolley is to pivot by 180 degrees the Lazy Susan (i.e. turntable) on which they sit, thereby also moving one person on the opposite end of the Lazy Susan into the path of the trolley and lethally exposing him, rather than the five, to the oncoming trolley. Not only is it permissible to turn the Lazy Susan, but the saving of the five strikes Kamm and others as no more morally problematic in this case than it does in the original Trolley Case. Kamm writes that, in the Lazy Susan Case, ‘we move a person into a threat rather than a threat into a person [as we do in the Trolley Case], but it makes no moral difference. Furthermore, if it is permissible to turn the Lazy Susan, it is so for the same reasons that make it permissible to redirect the trolley [in the Trolley Case].’²⁰

Kamm’s commitment to the permissibility of diversion in the Loop-Bridge Case gives rise to the following difficulty for her. It is a moral fixed point for Kamm and other non-consequentialists that it is impermissible to push the lever in the Bridge Case. Yet reflection on the similarities between the Bridge Case and the Loop-Bridge Case reveals the two to be morally indistinguishable. After all, in both cases you push

²⁰ F. M. Kamm, *Morality, Mortality*, vol. 2 (New York, 1996), p. 163. She immediately goes on to write that ‘*this helps us see that redirection* [of the threat such as a trolley] *is not morally crucial to redirection cases*’ (*Morality, Mortality*, vol. 2, p. 163). One might try to distinguish morally both the original Trolley Case and the Lazy Susan Case from the famous Transplant Case (where the only way to save five from vital organ failure is to carve up a healthy individual and transplant his organs into the five) by noting that both the Trolley Case and the Lazy Susan Case involve the *redistribution* (\neq redirection) of a threat by making it the case that the trolley that threatens the five now threatens the one. The carving up of the one in the Transplant Case, by contrast, is not a redistribution to the one of that which threatens the five. Perhaps you may kill one when this is necessary to save five just in case this killing is by means of the redistribution to the one of that which threatens the five. The problem with this suggestion is that it doesn’t account for the impermissibility of toppling the one in the Bridge Case, as in this case the threat that the trolley poses is redistributed (though not redirected) from the five to the one.

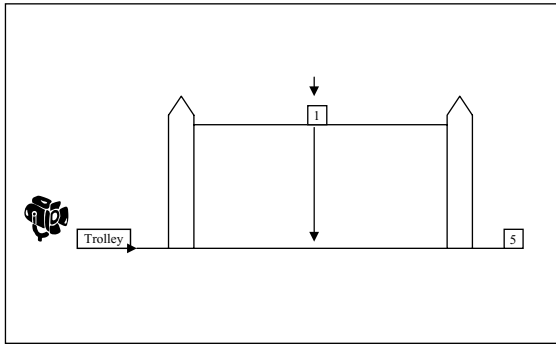

Figure 9. Illuminated Trolley Case.

a lever that causes someone to fall from the bridge and onto the track, thereby stopping the trolley that hits him. In the Loop-Bridge Case, the mechanism that connects your pushing of the lever to the toppling of the person from the bridge involves the temporary diversion of the train onto the circling track, whereas in the Bridge Case the mechanism does not involve this. It is, however, difficult to see how this difference in the causal pathways from the pushing of the lever to the toppling of the person from the bridge could make a moral difference between permissibility and impermissibility. Moreover, and crucially, it appears, contrary to Kamm, that in the Loop-Bridge Case as well as the Bridge case, you push the lever with the intention of getting the trolley to come to a halt by hitting the one – i.e. you push the lever in order that the trolley hit the one. Hence pushing the lever appears to be prohibited in both cases by the Doctrine of Triple Effect.

That you push the lever in order that the trolley hit the one in the Loop-Bridge Case can be demonstrated by highlighting the similarity between this case and the following case, which I shall call the Illuminated Trolley Case (Figure 9). In this latter case, your pushing the lever causes the trolley to be illuminated by a spotlight as it whizzes down the main track, and this light's reflection off the shiny surface of the trolley activates a sensor that causes the person to fall from the bridge.

Suppose that one were to try to offer the following defence of the permissibility of pushing the lever here that parallels Kamm's defence of the diversion of the trolley in looping cases. Your primary intention is that the trolley not hit the five at all. Because you intend that the trolley not hit the five at all, you intend the elimination of the current problem of an unilluminated trolley's hitting the five. In pushing the lever, you eliminate this problem by shining the spotlight on the trolley, thereby making it the case that an unilluminated trolley is not hurtling towards

the five. You now face the allegedly new problem of an illuminated trolley's hurtling towards the five. You realize that this new problem will be solved by the person's falling from the bridge and stopping the illuminated trolley before it hits the five. You do not push the lever in order that the trolley hit the one. Rather you push the lever only because it will hit the one.

This defence of pushing the lever is unsound because it lacks credibility to maintain that you activate the spotlight in order to eliminate the problem of an unilluminated trolley's hitting the five. You could not reasonably be motivated to eliminate such a problem, since you recognize that an unilluminated trolley's bearing down on the five and an illuminated trolley's bearing down on the five are one and the same problem. In abstraction from the fact that it would come to a halt by hitting the one as a result of its illumination, you do not eliminate or lessen the threat that the trolley poses by illuminating it. It is clear that you have no reason to illuminate the trolley except in order to eliminate the threat the trolley poses to the five by getting it to come to a halt by hitting the one before it hits the five. It is not as if you have reason, independent of the fact that the illumination will cause the one to fall in its path, to make it the case that an unilluminated trolley does not hit the five by illuminating it. Similarly, in the Loop-Bridge Case you have no reason to divert the trolley down the circular looping track except in order to eliminate the threat the trolley poses to the five by getting it to come to a halt by hitting the one before it hits the five. In abstraction from the fact that it would come to a halt by hitting the one as a result of its diversion, you do not eliminate or lessen the threat that the trolley poses by sending it on a circular detour. The illumination of the trolley, and its diversion down the circular looping track, are valuable merely as means to get it to come to a halt by hitting the one. Moreover, the Doctrine of Triple Effect would be drained of its force and thereby trivialized as a moral constraint on action if it were possible to steer clear of its prohibited aims and intentions by an artificial construction of your reasons for action as other than in order to get the trolley to hit the one in these two cases.²¹

²¹ Similar worries crop up in the literature on the Doctrine of Double Effect: e.g., 'He did not intend the killing of the one but merely that he be blown to bits', or 'In bombing this village, he did not intend the death of innocent civilians, but merely the realistic appearance of massive casualties'. It is an open question whether a moral principle that does not place any moral significance on one's actual state of mind could do a better job than the Doctrine of Triple Effect of distinguishing looping cases from the Bridge Case. On pp. 156–8, Kamm attempts to translate the state-of-mind talk involving intention, etc., of the Doctrine of Triple Effect into the non-state-of-mind vocabulary of the principles of permissible harming that she develops in that chapter. It is not clear to me, however, how such non-state-of-mind principles would categorize and distinguish the range of looping cases under discussion in this article.

II

In the light of the above discussion, I am led to wonder whether moral philosophers have been previously misled into thinking that it is permissible to redirect the trolley in looping cases. When I first encountered Thomson's Loop Case, it struck me as permissible to divert the trolley there because that case seemed so similar to the Trolley Case where you can divert the trolley onto a side track that does not loop back around to the main track. In comparing these two cases, Thomson writes that 'we cannot really suppose that the presence or absence of that extra bit of track [that loops back] makes a major moral difference as to what the agent may do in these cases'.²² To bolster Thomson's claim, we might stipulate that, in the Trolley Case as in the Loop Case, the mass of the one on the side track is sufficient to stop the redirected trolley – though this serves no useful purpose in the Trolley Case because the trolley would just have carried on harmlessly if the mass of the one hadn't been sufficient to stop it. Given that the trolley will be stopped by the one in any event and will never travel down the side track beyond the one, how can it make a moral difference whether this never-to-be-travelled track carries on harmlessly or loops back to the five? Moreover, we're confident that it is permissible to redirect in the Trolley Case, and we find it difficult to distinguish this case morally from the Loop Case, so we're primed to deem redirection permissible in the Loop Case.

As I have shown above, however, the Loop-Bridge Case reveals that the same sort of pull can be exerted from the other direction. We're confident that it is impermissible to topple the one from the bridge in the Bridge Case. But then we note that the Loop-Bridge Case seems morally indistinguishable from this clearly impermissible Bridge Case, so we conclude that it is impermissible to kill the one in the Loop-Bridge Case. We also observe that the Loop-Bridge Case is difficult to distinguish from the Loop Case. Hence, we might be led to conclude that it is impermissible to kill the one in the Loop Case as well.

Consider also the following Ramp Case (Figure 10) that is also very hard to distinguish morally from the Bridge Case. In this case, which is a slight variant of a case of John Fischer's, you can stop the trolley from hitting the five by opening a drawbridge. So doing will send the trolley up the ramp of the open drawbridge and into the air, where it will hit one person standing on a pedestrian bridge overhead. The trolley's hitting the one will stop its forward progression and cause it to fall into the water below the drawbridge. The trolley's hitting the one will also kill him. If, however, the one had not been overhead, then the

²² Thomson, 'The Trolley Problem', p. 1403.

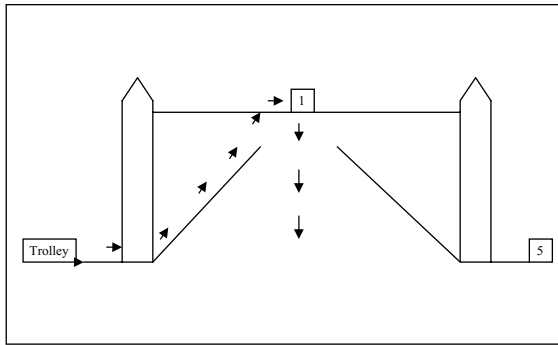

Figure 10. Ramp Case.

trolley would have managed to fly over the gap, land on the downward sloping ramp, and hit and kill the five.

This case differs from the Bridge Case in the following respect: rather than causing the one to fall from the pedestrian bridge, pushing the lever causes the trolley to ascend a ramp and sail onto the pedestrian bridge. This case therefore differs from the Bridge Case in so far as you move the trolley into the path of the person rather than the person into the path of the trolley.²³ We have learned, however, that this difference is morally insignificant in comparing the Trolley Case with the Lazy Susan Case. Given our intuition that it is impermissible to kill the one in the Bridge Case, we're therefore inclined towards the view that it is impermissible in the Ramp Case to send the trolley up the ramp and into the person on the pedestrian bridge. The Ramp Case appears, however, to be completely morally indistinguishable from the Loop Case: the factual differences between these two cases do not appear to make the slightest moral difference. If it is impermissible to launch the trolley upwards towards the one in order to stop it in this Ramp Case, then how could it be permissible to divert the trolley towards the one in order to stop it in the Loop Case? Is there a moral distinction to be drawn between horizontal and vertical diversions?²⁴

Now that we realize that looping cases are vulnerable to assimilation challenges from both directions, we need to ask ourselves whether the cost of morally assimilating looping cases to the Trolley Case (that cost

²³ Both the Ramp Case and the description of the manner in which it differs from the Bridge Case are due to John Martin Fischer. See his 'Thoughts on the Trolley Problem', *Ethics: Problems and Principles*, ed. John Fischer and Mark Ravizza (Fort Worth, Tx., 1992), pp. 308–17, at pp. 315–16.

²⁴ This is, of course, a rhetorical question. I concur with Fischer that 'whether the train is shunted to the right or upward cannot be morally significant' (Fischer, 'Thoughts on the Trolley Problem', p. 316).

being that of morally differentiating these cases from the Bridge Case) is greater than the cost of morally assimilating looping cases to the Bridge Case (that cost being that of morally differentiating these cases from the Trolley Case).

It is hard to morally differentiate looping cases from either the permissible Trolley Case or the impermissible Bridge Case. But, in reflecting on the Loop-Bridge Case and others like it, I suspect that it is harder to morally differentiate looping cases from the Bridge Case than it is to morally differentiate them from the Trolley Case. After all, the apparently morally significant distinction between treating as a means and not so treating appears to distinguish looping cases from the Trolley Case. It is much harder to find a morally significant difference between looping cases and the Bridge Case. Kamm has, for example, tried to distinguish these cases by means of an appeal to the distinction between doing something in order to get the trolley to hit the one and doing it only because the trolley will hit the one. Yet I have argued that her attempt is unsuccessful.²⁵

I think it is worth drawing attention to the fact that, unlike some other examples in normative ethics such as those involving terror bombing versus strategic bombing, looping cases are not modelled on any real-world cases with which we are familiar and about which we have already formed reactions. The first encounter of readers of this article with a looping case will probably have been either in the pages of Thomson's 1985 article 'The Trolley Problem' or through discussion of this type of case that was ultimately inspired by this particular article. It is an interesting question whether the widely shared intuition of moral philosophers that it is permissible to turn the trolley in various looping cases is an artefact of the fact that our initial exposure to this type of case has been so strongly influenced by Thomson's inauguration of the Loop Case in the context of the Trolley Case. Perhaps the history of this branching, looping, spinning, revolving problem in moral philosophy would have gone very differently if the first version of a looping trolley case to which moral philosophers had been exposed was the Loop-Bridge Case that makes its debut in this article. Had that been our first looping case, and had it been presented in the context of the Bridge Case, we might instead have intuited the impermissibility of turning the trolley in this and other looping cases. In fact, I presented the Bridge Case and then the Loop-Bridge Case to undergraduates in a recent lecture course. I did so before I exposed

²⁵ Might others succeed where Kamm has failed to distinguish the Bridge Case (and others like it) from looping cases? I very much doubt it, as I suspect that Kamm's writings on the trolley problem over the years have either refuted any such published attempt or provided the resources with which to construct a refutation.

them to the Trolley Case. By a show of hands, a majority of those willing to venture an opinion deemed it impermissible to kill the one in the Loop-Bridge Case as well as the Bridge Case (though the majority was smaller in the Loop-Bridge Case). It is also significant that, as I have noted above, the opinion of those who took Marc Hauser's online Moral Sense Test was divided 50–50 regarding the permissibility of diverting the trolley in a version of a looping case highly similar to Thomson's. Presumably many of these respondents were internet users who had not been previously exposed to Thomson-influenced discussion of the trolley problem. Moreover, Hauser's statistics were drawn only from people's responses to the *first* case that they encountered in the online survey, thereby screening out the influence of other cases on their convictions regarding permissibility.²⁶

I shall conclude with an invitation to moral philosophers to reject, as a moral illusion, the intuition that it is permissible to divert in looping cases rather than prolonging the quest to find a theoretically satisfying, principled means of explaining the permissibility of the killing of the one as a means in such cases. We have strong theoretical grounds for affirming the moral significance of the fact that one is using someone as a means.²⁷ Moreover, there is a wealth of concrete cases in which we recoil from the harmful using as a means. Our willingness to permit such harmful using as a means in looping trolley cases is therefore anomalous. Given our difficulty in accounting for this anomaly in theoretically satisfying, principled fashion, plus the suspicions I have voiced in the previous paragraph regarding the formation of this intuition, it is time for moral philosophers to abandon our conviction that it is permissible to use the death of the one as a means to the saving of the five in looping trolley cases.

m.otsuka@ucl.ac.uk

²⁶ See Hauser, *Moral Minds*, pp. 128–9.

²⁷ See Warren Quinn, 'Actions, Intentions, and Consequences: The Doctrine of Double Effect', *Philosophy and Public Affairs* 18 (1989), pp. 334–51.