

The dual-frequency sonar system of the mobile robot RAM-2

M. A. Martinez* and J. L. Martinez

Department of System Engineering and Automation, University of Málaga, E.T.S.I. Industriales, Plaza El Ejido s/n, 29013 Málaga (Spain)

(Received in Final Form: September 24, 2003)

SUMMARY

This paper deals with the design and development of a new perception system for controlling a set of ultrasonic transducers working at two different frequencies generated by a digital signal processor (DSP). Data gathering speed is increased by the simultaneous firing of sonars without crosstalk problems. The software and hardware implementation are presented as well as the results from the calibration process and the integration on board the mobile robot RAM-2. Finally, a demonstration of the use of the proposed equipment to wall-following via a fuzzy controller is described.

KEYWORDS: Ultrasonic transducers; Mobile robots; Signal processing; Fuzzy control.

1. INTRODUCTION

Ultrasonic sensors have been widely used in mobile robotics as a low cost and reliable means for vehicle localization and environmental sensing. The main technique employed to measure the distance between the sonar and objects has been the time-of-flight (TOF).

To apply this technique, a short burst of ultrasonic energy is generated, amplified and transmitted by a transducer. The signal travels through the air, reflects from the target object and returns to the same transducer¹ and, sometimes, to other ones working only as receivers.² When received, this signal is amplified and processed to determine the time of flight, and knowing the sound speed, the distance to the object can be calculated.

One of the chief drawbacks associated with TOF technique is the chance of a sound burst from one sensor being detected by neighbouring sensors. This problem is known as crosstalk. Several approaches have been developed to reject the errors caused by crosstalk. The simpler way is to slow down the rate of data collection, but this solution is, obviously, very inefficient for several sonars (e.g. a ring of sonars).

Borenstein and Koren proposed Error Eliminating Rapid Ultrasonic Firing (EERUF);³ a method based on the principle of comparison consecutive readings, but, in addition, it employs alternating delays before firing each sensor. Moita and Nunes introduced the Multi-Echo Error Eliminating Rapid Ultrasonic Firing (MEEERUF),⁴ an upgrade of the previous EERUF method that can be used not

only to eliminate the undesirable echoes, but also to identify the echoes proceeding from adjacent sensors, i.e. a desired crosstalk to implement feature detection algorithms.

A different approach was demonstrated by Jorg and Berg⁵ who modulated the frequency of the sonar signals with pseudo-random sequences, thus giving each sonar a recognizable signature. Then, a matched filter in the receiving circuit identified the associated source sonar. This method is based on applying correlation techniques well known from radar theory.

In order to identify the source of each echo, Shoval and Borenstein⁶ presented a method for assigning a unique identification code to the signals emitted by each sonar, so that the source sonar can be identified even if its signals' echo is received by another sonar. Each sonar transmits a number of pulses fired in sequence, the exact number of which is determined by a unique code.

In this paper a new alternative approach is presented. The transducer can operate at two different frequencies selected according to the transducer's usable transmitting and receiving frequency range. In this way, crosstalk is avoided between neighbouring sonars that work at different frequencies.

One of the most popular sonar systems in mobile robots is the Polaroid 6500 ranging module together with one of the Polaroid transducer. Harris and Recce⁷ describe empirical models of TOF sonars, derived from large quantity of data collected with the Polaroid ultrasonic rangefinder. In others works^{4,6} the Polaroid 6500 ranging module is used to control the transducer without any additional interface because the operational mode do not need any additional feature, for instance, if it always transmit sixteen pulses at 49.4 kHz.

When it is necessary to introduce some changes in the transducer operation mode, a specific hardware has to be implemented instead of the Polaroid 6500 ranging module. Several authors include DSP's in their solutions because of their computing power. In the job of Jorg and Berg⁵ during the transmit phase, the DSP acts as a generator of a pseudo-random sequence that constitute the burst of each individual sonar sensor. During the receive phase, the DSP performs the processing of the returns including a Fast Fourier Transformation for an efficient matched filter implementation.

Heale and Kleman⁸ used the DSP as an echo processor for an optimal arrival time estimation of echoes with short duration and wide bandwidth. Korba¹ provides an effective control over the sensitivity volume for the sensors control-

* Corresponding author. E-mail address: mams@ctima.uma.es

ling, with the DSP, the length of the pulse train used to excite the transducers and the depth gain compensation curve used during reception of sonar echoes.

This paper also studies the use of a sonar system based on Polaroid transducers controlled by a DSP. Sonar data preprocessing is carried out by the DSP. Sonars are continuously fired and when enough data is available, the mean is calculated and erroneous data rejected.

The new perception system has been integrated into the mobile robot RAM-2 and applied to wall following. The ultrasonic sensors provide information about the position of the vehicle in terms such as far away, near, rotated to the left or to the right. A description of this type can be properly processed by using fuzzy logic.

The rest of the paper is organized as follows: The next two sections describe the involved hardware and software. Section 4 includes the experiments carried out in order to test and calibrate the sonars. Section 5 analyses the performance of the data acquisition system in the mobile robot RAM-2. A fuzzy controller based on the information provided by the sonar system is described in Section 6. Finally, the last sections are devoted to conclusions, acknowledgements and references.

2. SYSTEM'S HARDWARE

The transducers employed in RAM-2 are from the Polaroid 600 series.⁹ They have a fairly flat frequency response from 20 kHz to 100 kHz. This is why the two frequencies selected are 50 kHz and 70 kHz.¹⁰

The hardware that can drive the Polaroid transducers is composed of a digital block, one analog block for every sonar, and the corresponding analog to digital and digital to analog interfaces. Two kinds of analog block circuits, one for each frequency, have been designed in order to drive the transducer and amplify and process the received signals.

In Figure 1, the connection of the digital block with one of the analog block by the corresponding interfaces is represented. This hardware carries out the following tasks:

- (i) Signal generation for working with sonar transducers at two different frequencies.

- (ii) Power circuit for adapting the signals that enable the sonars to transmit the sound burst.
- (iii) Echo reception by the sonar transducer working as a receiver.
- (iv) Processing the signal received in order to calculate the time of flight of the ultrasonic waves.
- (v) Interface with the computer that requests data from the sonars.

In the following subsections the analog block, the digital block and the interfaces are described in detail.

2.1. The analog block

Since every sonar works as transmitter and receiver, it is necessary to isolate emission and reception paths. So, there are analog switches in the transmission and reception lines controlled by the DSP that allow for alternating these functions.

The emission line has the following components (see Figure 1):

- (i) The filter for selecting one of the two frequencies generated by the DSP and needed for every sonar's sound burst emission.
- (ii) The analog switch that enables or disables the transmission path.
- (iii) The amplifier for adjusting the levels necessary in the primary side of the transformer (included in the adapter block) that works at a transformation rate of 45. As a peak voltage of about 200 volts is necessary at the output of the transformer, the selected amplifier increases the signal to a peak level of 4 V and an intensity level of 3 A.
- (iv) The adapter is composed of a transformer with the secondary side connected to a circuit based on a capacitor and two zener diodes that supply the necessary voltage when the sonars are listening.

The reception path is composed of:

- (i) A preamplifier that increases the low level of voltage arriving from the sensor.
- (ii) The Programmable Gain Amplifier (PGA) that applies a level which is a function of the time between the

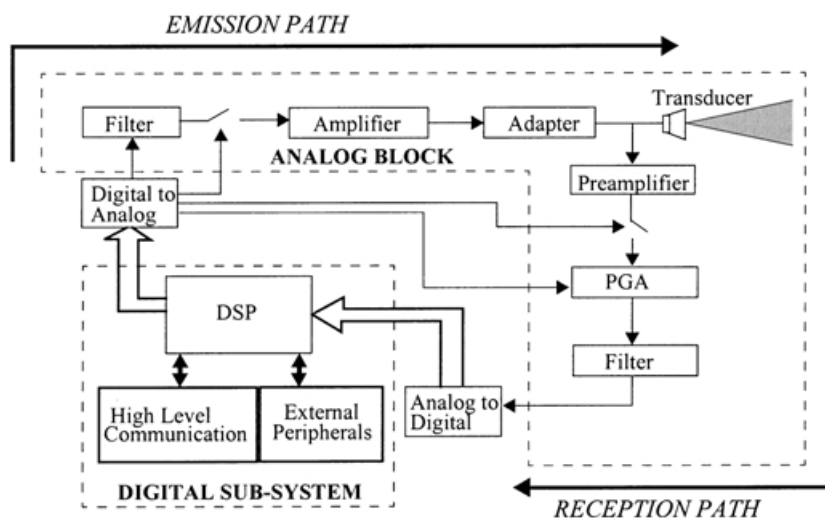

Fig. 1. Data acquisition system.

emission and the reception of the signal. The PGA is implemented by a D/A converter where the gain applied is provided by the DSP that stores in a table the different gains as a function of the time elapsed from the transmission of the wave. The rate of gain change takes place every 1.714 ms.

- (iii) Finally, in the analog sub-system it is necessary to filter the signal in order to reject the frequencies different from the emission one. Subsequently, the filtered signal goes to a level detector that holds the highest level of the signal detected in the filter.

2.2. The digital sub-system

The digital sub-system is composed of the main processor, a set of external peripherals and the interface with the computer (see Figure 1).

The signal processor used is the Texas Instruments DSP TMS320C31. This processor coordinates the behaviour of the complete system. The right use of the analog and digital interfaces collecting signals from external peripherals and providing control signals to them allows the system to operate properly. The two internal timers provided by the processor work as a source of internal interrupts and are used in tasks where time is a critical factor such as when the samples are written for wave generation or when it is time to change the gain applied to the received signal.

The external peripherals are composed of registers controlled by the DSP as input or output ports. Some of them are the control transmission register and the interrupt register. The DSP writes the control transmission register for selecting the transducers that work every time and also, because each transducer works as a transmitter and receiver, for isolating the transmission and reception paths. The interrupt register is employed to allow the DSP to recognize the ultrasonic sensor that has generated the incoming echo interrupt; the same interrupt line is shared by all the sonars, hence it is necessary to read this register to distinguish the interrupter. The communication with a computer is carried out by a serial channel RS-232 implemented by an UART.

2.3. Interfaces

The system includes two interfaces for connecting the analog and digital blocks. The digital to analog interface is used for writing a D/A converter with the values stored in the DSP memory in order to generate the transmission signal. It is also used for controlling the analog switches (composed of TTL drivers for opening and closing JFET transistors) that select the transmission and reception paths. Finally, this interface is used for digital selection of the gain in the PGA.

The analog to digital interface is used to interrupt the DSP when an echo with a high enough level is detected in the reception path. It is composed of a level detector for capturing the highest level of incoming signal in the reception path, a unit for comparing detected levels with a reference level (previously adjusted by hardware), and finally, an information generator that collects signals of correctly detected echoes to report to the DSP (see

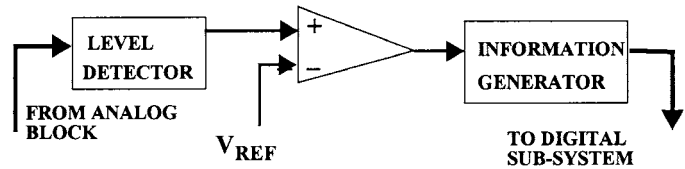

Fig. 2. The analog to digital interface.

Figure 2). In the information generator, each of the lines of incoming echoes sets the corresponding bit in the interrupt register and all these lines are added in an OR-logical way to produce the interrupt signal that goes to the DSP.

3. SOFTWARE'S DESCRIPTION

The control software is composed of a set of DSP routines that determines the system's behaviour. The states for controlling the system are shown in Figure 3 where each state is composed of one or more routines that depend on timers that belong to the DSP or on external interrupt signals, such as the echo detected by a sonar or the data requested by the computer. All the code has been programmed in assembler language for the TMS320C31 processor. The main routines and the tasks performed by each one are:

- (i) The loading routine for transferring the program from external EPROM to internal RAM after the reset interrupt to increase the overall system's operation speed.
- (ii) The routine that initializes the system to carry out tasks such as writing a register with the memory address of the wave generation D/A converter, enabling the operation of the analog transmission and reception gates for correct use of the sonars, programming the UART for communications with the computer and, in general, internal registers programming.
- (iii) The starting routine that reads the data from the computer when an external interrupt is received. This information selects the way of working, such as the sonars to be used.
- (iv) The wave generation routine which selects the samples of the periodic signal from internal memory and writes then into the D/A converter.

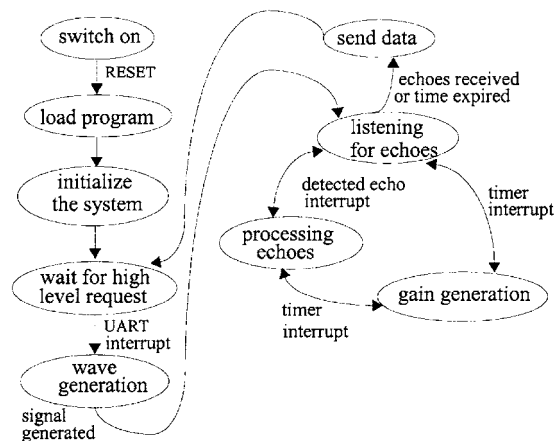

Fig. 3. States for controlling the ultrasonic system.

- (v) The end of transmission routine which stops the wave generation and programs timers as well as other registers in order to prepare the system for echo reception. One of the timers is used to generate an interrupt every 1.714 ms that updates the gain applied to the receiver path. The other timer function is the control of the maximum time of listening for the echoes. This routine also programs a waiting loop of 600 s after the end of the transmission signal in order to allow enough time for the energy in the transducer diaphragm to decay below the threshold level and avoid false echo detection.
- (vi) The gain generation routine that runs every time the timer generates one interrupt, reads the gain data from memory and loads it into the PGA. The same gain values are applied for both excitation frequencies.
- (vii) The end of listening routine which ends the incoming echo wait state. The sonars that have detected echoes have the listening time stored in memory, whereas the others have the initial value (all bits zero).
- (viii) The processing echoes routine that runs every time an interrupt caused by a detected echo arrives to the processor. The program computes the time of flight and the sonar that has received the echo. This elapsed time is stored in an appropriate memory position, corresponding to the sonar receiver.

The double arrows in Figure 3 means that it is necessary to update the gains applied to the received signal (the corresponding timer interrupt must be enabled), both when the system is in the listening echo state and when it is processing a received echo.

4. TEST AND CALIBRATION

The following experiments have been carried out to check that the crosstalk problem is avoided. In Figure 4a, two sonars working at different frequencies have been placed side by side and in front of a target object. Another object with a reflective surface is placed in the way of the 70 kHz sonar in order to disturb the 50 kHz sonar reception. As seen in Figure 4b, the frequency filter in the reception path allows the 50 kHz sonar to work correctly, as if no other sonar was near it, except for a small perturbation which does not trigger the level detector as a valid echo. The same interference experiment has been tested by swapping the role of the frequencies. The subject of another experiment has been the calibration of the sonars. The DSP measures

the time of arrival of the first echo from each sensor. The values obtained by the 50 kHz and 70 kHz sonars placed in front of a wall at several distances are represented in Figure 5. The distance resolution is 1.2 cm. The lineal approximation is given by the following expression:

$$d = 15 + 1.2 \cdot u \quad (1)$$

where u is the value of the DSP counter and d is the actual distance (in cm). When the sonars are separated less than 15 cm from the wall, they do not work correctly. The time between sonar fires is 33 ms. That means a data acquisition frequency of 30 Hz for every sonar, because they can be fired simultaneously.

5. INTEGRATION IN THE MOBILE ROBOT

RAM-2 is a mobile robot designed for indoor environments (see Figure 6). It is completely powered by a set of six car-like batteries but it also allows direct connection to the AC electric network.

The vehicle locomotion system has four wheels located in the vertices of a rhombus, the main diagonal of which is the longitudinal axis that includes the rear and front steering wheels, while the propulsion wheels are located to the left and the right of the vehicle. This is a non-holonomic configuration; the main drawback of which is the actuator redundancy that arises from synchronizing the steering and propulsion wheels to achieve a particular curvature. The top speed of 1.6 m/s can only be reached when the vehicle moves along a straight line, and automatically decreases to zero as the desired curvature increases.

The beam pattern produced by a sonar has a divergence angle θ which is a function of the ultrasonic wave frequency f , the speed of sound c (about 343 m/s at 20°C) and the transducer radius a (approximately 19 mm). It is given by the function:

$$\theta = \arcsin \frac{c}{f \cdot a} \cdot 0.61 \quad (2)$$

The divergence angles calculated for each frequency are 12.72° for 50 kHz and 9.05° for 70 kHz. The transducers are placed in RAM-2 at a height of 45 cm from the floor so it is necessary to consider the reflections from it when they are fired towards a target. As the amplitude of the beam patterns depends on the frequency, the reflections may occur at

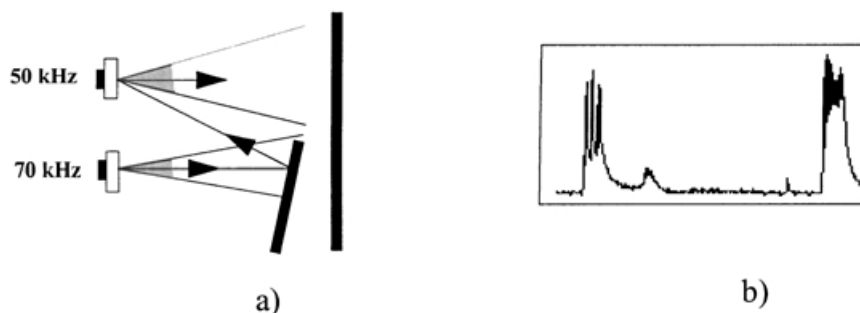

Fig. 4. Frequency interference test.

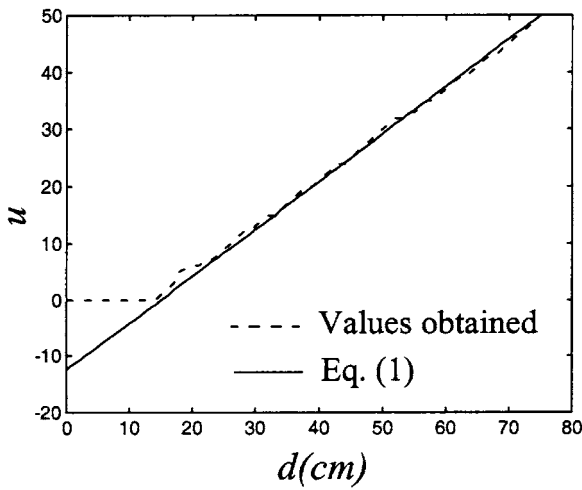

Fig. 5. Calibration of the sonar system.

distances of 1.99 m (corresponding to 50 kHz frequency) and 2.83 m (70 kHz).

As the DSP controls the gain amplifier (PGA) applied to the received echoes, it is possible to reduce the depth of view of the sonars to echoes from objects closer than 1.8 m approximately. In this way, reflections from the floor are avoided and the same gain table can be applied independently of the transducer's working frequency.

For local navigation, RAM-2 makes use of a laser scanner located at 0.3 m from the ground that provides scans in front

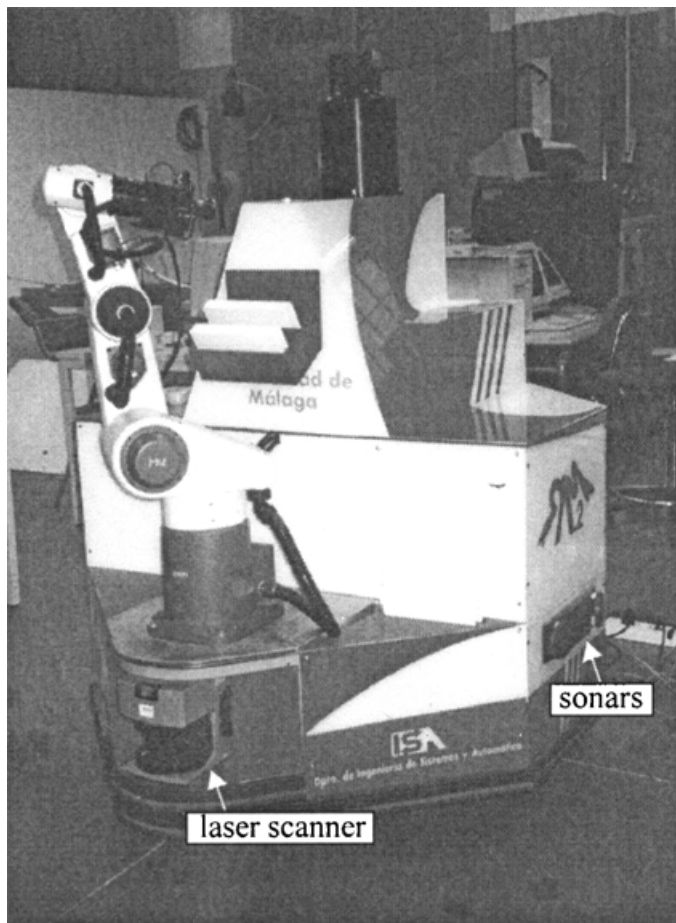

Fig. 6. The RAM-2 mobile robot.

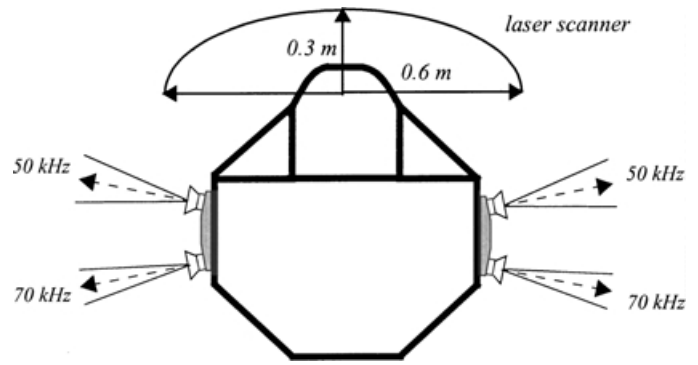

Fig. 7. Detection areas.

of the vehicle. Also, on the right side and on the left side of RAM-2, two sonars working at 50 kHz and 70 kHz have been placed in the configurations represented in Figure 7. The position of both sonars is almost normal to the robot surface but while the 70 kHz sonar direction is slightly turned to the back, the 50 kHz is slightly turned to the front.¹¹

The purpose of the placement of the sonars shown in Figure 7 is to distinguish when the vehicle, from a position parallel to a wall, changes its direction turning to the left or to the right. With this information it is possible to correct the curvature of the vehicle in order to follow a wall.¹²

As can be observed in Figure 8, if the vehicle is in area A, both sonars detect the wall simultaneously while the robot is approximately parallel to the wall. If the vehicle changes its direction slightly to the left, it goes to the area B where the 70 kHz sonar improves its detection because it returns to the

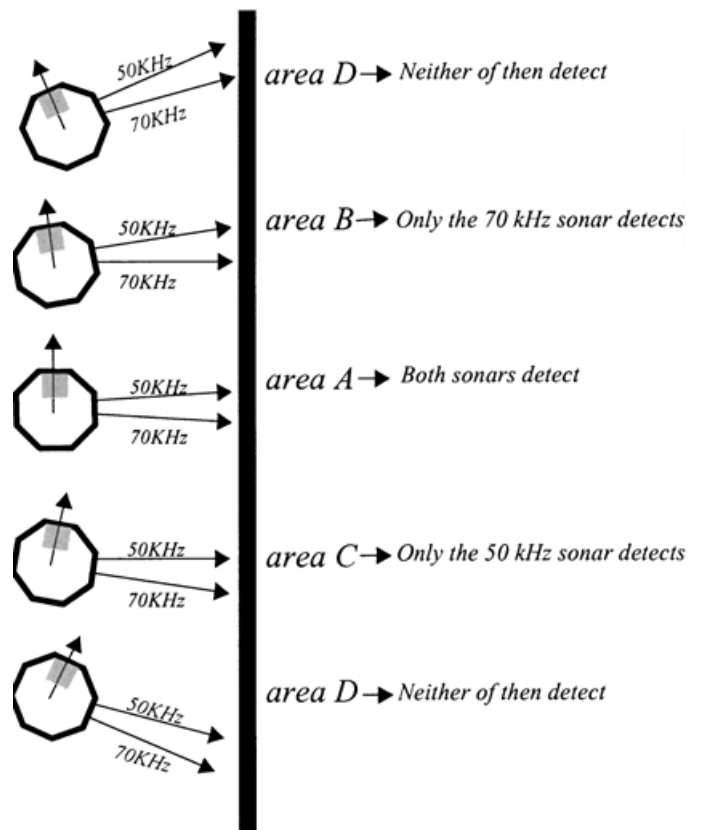

Fig. 8. Working areas of the sonars.

normal position to the wall providing the minimum distance. In this situation, the distance detected by the 50 kHz sonar will increase until the wall is lost.

If the mobile robot is in the area A and the change of direction is to the right, the distance provided by the 50 kHz sonar decreases, reaching the minimum when it is normal to the wall. Now, the 70 kHz sonar has a worse orientation providing distances that increase before losing detection.

Because the information supplied by the transducers may have errors, it is necessary to filter distances. The filter eliminates isolated errors as well as the noisy distances provided when the angles to the wall are big (near the limit of detection).

6. FUZZY WALL FOLLOWING

The fuzzy controller has been designed under two assumptions. Firstly, the distance between the lateral side of RAM-2 where the sonars are placed to the wall is less than 1.8 m. Secondly, the fuzzy controller can only work if at least one of the two sensors provides a distance to the wall.

The end of the wall following task occurs when the corner of the wall is detected. The frontal wall of inner corners can be sensed by the laser scanner whereas the outer ones are detected when the mobile robot remains in area D for a certain amount of time.

The objective of the fuzzy controller is to take readings from sonars as inputs and then decide in which direction it has to steer the vehicle. The speed of the vehicle is kept constant at 0.3 ms^{-1} for the purpose of this work. The fuzzy controller starts to work when both sonars detect the right wall and it consists of a set of few rules which represent instructions to the mobile robot. Similar rules have been derived for left walls.

The first input is the error between the mean of distances provided by both sonars and the desired distance:

$$\text{error} = \frac{d_{50} + d_{70}}{2} - d_{ref} \quad (3)$$

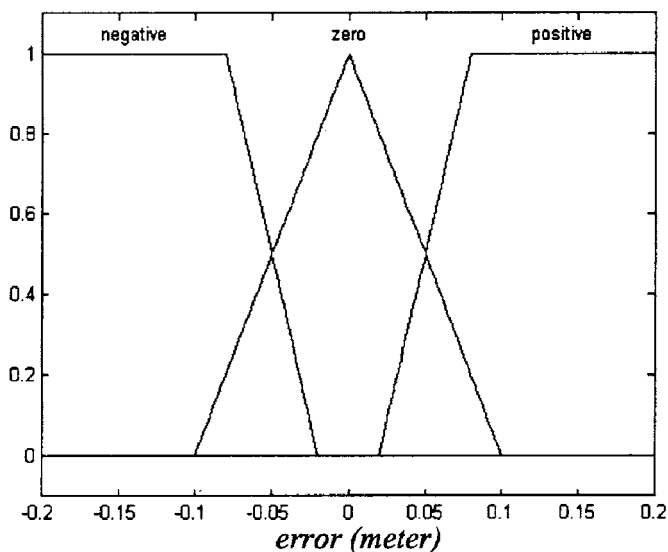

where d_i means the distance supplied by the sonar which works at the i frequency and d_{ref} the reference distance. Three fuzzy sets have been defined for this variable: NEGATIVE, ZERO and POSITIVE.

The other input considered has been the difference between the values of both sonars as an indication of deviation from the wall:

$$\text{deviation} = d_{50} - d_{70} \quad (4)$$

The possibilities for this input are: PARALLEL, COME_NEAR and GO_AWAY. Figure 9 shows all the membership functions of the fuzzy sets of the two inputs.

The only output variable is the curvature that must be applied to RAM-2 with five different possibilities NULL, POSITIVE, NEGATIVE, BIG POSITIVE and BIG NEGATIVE. Figure 10 shows all the membership functions of the fuzzy sets of this output.

Laser scanner and sonars work simultaneously. While the laser scanner is in charge of security by continually testing for obstacles in front of RAM-2, the ultrasonic system provides data to the fuzzy controller in order to follow a wall to a prearranged distance.

The rule base is composed of eight rules formulated in the classical form:

IF <conditions> THEN <consequences>

In this work, the Mamdani fuzzification technique has been used as well as the centre of gravity defuzzification method to obtain a fairly smooth navigation. The rules are the following:

Area A:

- (i) If (error is positive) then (curvature is big-negative).
- (ii) If (error is negative) then (curvature is big-positive).
- (iii) If (error is zero) and (deviation is go_away) then (curvature is negative).
- (iv) If (error is zero) and (deviation is come_near) then (curvature is positive).

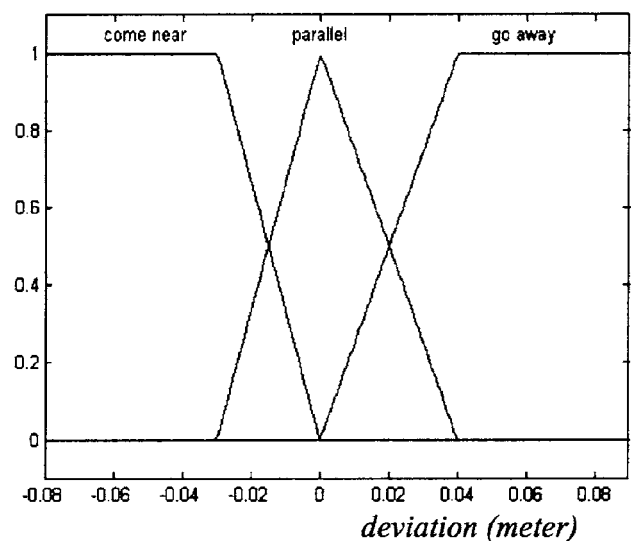

Fig. 9. Fuzzy sets for the input variables to the fuzzy controller.

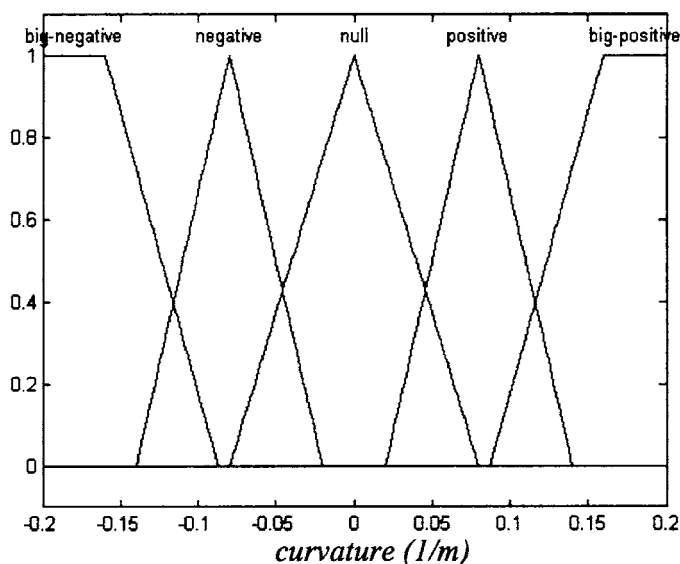

Fig. 10. Fuzzy sets for the output variable.

(v) If (error is zero) and (deviation is parallel) then (curvature is null).

Area B:
(curvature is big-negative).

Area C:
(curvature is big-positive).

Area D:
(curvature is zero).

In order to check the performance of the proposed controller, in the following experiment, RAM-2 follows the wall mainly composed of glass located to its right. The laser device can hardly be employed in this situation because it produces a lot of spurious ranges. While it navigates, RAM-2 can find obstacles which are detected in the security area of the laser scanner (see Figure 7). In case that the expected distance has not been travelled (approximately given by odometry), RAM-2 stops and waits for the obstacle to disappear before continuing its task.

In Figure 11 it can be observed a sequence of three photographs taken when RAM-2 was following a 16 m length right wall at 0.40 m from it at 0.3 ms^{-1} . In the first image, RAM-2 is rotating until a good detection of both sonars is accomplished; after that, it starts following the right wall as shown in the second image. Finally, in the third image, RAM-2 stops because a frontal wall is detected by the laser scanner.

8. CONCLUSIONS

In this work, a dual ultrasonic system for mobile robots has been presented. The main advantage of this system is the possibility of simultaneously firing neighbouring sonars without the crosstalk problem. This fact increases at least twice the speed of data acquisition.

The capabilities introduced by the DSP have been used to calculate the average of several measured distances and for easily modifying the work conditions of the sonars, such as the time between firings.



a)



b)

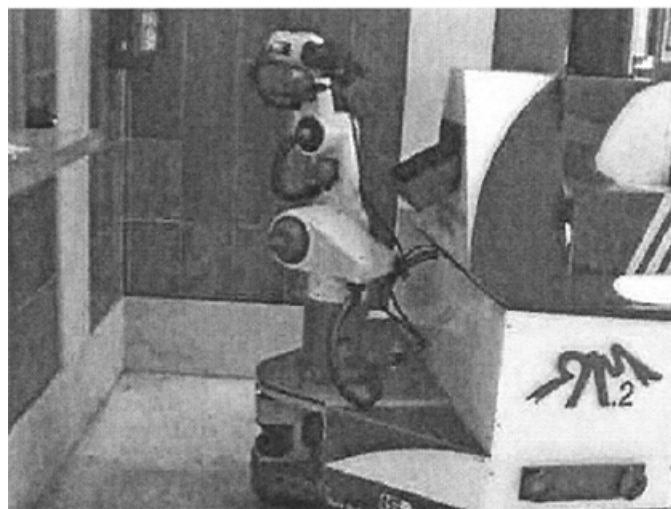

c)

Fig. 11. Wall following experiment.

With a set of eight fuzzy rules, satisfactory results have been obtained for wall following in the mobile robot RAM-2. The reason for this control simplicity is the additional information about working areas provided by the ultrasonic system in addition to numerical ranges.

Future work includes the employment of a third frequency and the installation of a complete ring of sonars around RAM-2.

Acknowledgements

This work has been partially supported by the Spanish Government under project DPI 2002-01319.

References

1. L. Korba, "Variable Aperture Sonar for Mobile Robots", *Proc. IEEE International Conference on Robotics and Automation* (1994) pp. 3136–3141.
2. L. Charbonnier and A. Fournier, "Heading Guidance and Obstacles Localization for an Indoor Mobile Robot", *Proc. International Conference on Advanced Robotics* (1995) pp. 507–513.
3. J. Borenstein and Y. Koren, "Error Eliminating Rapid Ultrasonic Firing for Mobile Robots Obstacle Avoidance", *IEEE Transactions on Robotics and Automation* **11**, No. 1, 132–136 (1995).
4. F. Moita and U. Nunes, "Multi-Echo Technique for Feature Detection and Identification using Simple Sonar Configurations", *Proc. International Conference on Advanced Intelligent Mechatronics* (2001) pp. 389–394.
5. K.W. Jörg and M. Berg, "Mobile Robot Sonar Sensing with Pseudo-Random Codes", *Proc. IEEE International Conference on Robotics and Automation* (1998) pp. 2807–2812.
6. S. Shoval and J. Borenstein, "Using Coded Signals to Benefit from Ultrasonic Sensor Crosstalk in Mobile Robot Obstacle Avoidance", *Proc. IEEE International Conference on Robotics and Automation* (2001) pp. 2879–2884.
7. K.D. Harris and M. Recce, "Experimental Modelling of Time-of-Flight Sonar", *Robotics and Autonomous Systems* **24**, 33–42 (1998).
8. A. Heale and L. Kleeman, "A Real Time DSP Sonar Echo Processor", *Proc. International Conference on Intelligent Robots and Systems* (2000) pp. 1261–1266.
9. Polaroid (<http://www.polaroid-oem.com>), *Technical Specifications for 600 Series Instrument Grade Electrostatic Transducers and 6500 Series Sonar Ranging Module*.
10. M.A. Martínez, J.F. González and J.L. Martínez, "The DSP Multi-frequency Sonar Configuration of the RAM-2 Mobile Robot", *Proc. of the 2nd IEEE Euromicro Workshop on Advanced Mobile Robots*, Brescia, Italy (1997) pp. 113–119.
11. M.A. Martínez and J.L. Martínez, "The Use of a DSP Based Dual-Frequency Sonar System in the Mobile Robot RAM-2", *Proc. of the 3rd Portuguese Conference on Automatic Control*, Coimbra, Portugal (1998) pp. 871–873.
12. T. Yata, L. Kleeman and S. Yuta, "Wall Following Using Angle Information Measured by a Single Ultrasonic Transducer", *IEEE International Conference on Robotics and Automation* (1998) pp. 1590–1596.