Orchestra Machines, Old and New

JONATHAN DE SOUZA

Don Wright Faculty of Music, Talbot College, Western University, 1151 Richmond St, London, ON N6A 3K7, Canada
Email: jdesou22@uwo.ca

What is ‘orchestral’ about a networked laptop orchestra? And what is network-like about a classical orchestra? This article juxtaposes orchestras, nineteenth-century music machines and twenty-first-century network music projects. Drawing on organology and cybernetics, it asks how these systems connect people and instruments. It considers interaction and coordination in particular networks, from the panharmonicon to PLork, but also their abstract informational topologies. Ultimately, orchestra machines, old and new, involve both technical and social organisation – and, as such, they can be used to problematise the ontological separation of technology and society.

1. INTRODUCTION

Composing is commonly understood as a solitary activity, a kind of writing. In this view, the act of composition – from sketching to orchestration – is an act of notation. Some composers might use a piano or other instrument, of course, but these would be seen as inessential supplements. Yet in a technological age, composition is often distributed and explicitly mediated. Composers, in this context, might collaborate with engineers or producers, exploring new media for sound recording and reproduction. Such systems eliminate the need for traditional performers, and they might be appreciated for their technological innovations as much as their sonic output. They can also offer composers extended musical materials, facilitating creative sampling of pre-existing pieces, and blurring the boundary between music and noise. The resulting soundscapes combine aesthetic, technological and often political significance. When music is inextricable from technology, composition is much more than paperwork.

This description of technologised composition hints at the work of electroacoustic musicians in the twentieth and twenty-first centuries. But it can apply to eighteenth- and nineteenth-century composers too. I am thinking, in fact, of Ludwig van Beethoven. In 1813, Beethoven composed his *Wellingtons Sieg*, op. 91, for a cutting-edge musical technology: a panharmonicon invented by Johann Nepomuk Mälzel (see Figure 1). According to a report from the same year, ‘One must be astonished at the immense quantity of the instruments in the panharmonicon ... The effect

which this work of art makes is extraordinary; one feels that one is hearing a whole orchestra’ (Wolf 2012: 311–12). Mälzel – who is largely remembered for popularising the metronome – was well known as a technologist. He demonstrated his panharmonicon publicly, just as he demonstrated other inventions, including a trumpet-playing android, artificial limbs and a notorious chess automaton. Many commentators understood *Wellingtons Sieg* as a collaboration, claiming that key ideas in the piece originated with Mälzel (Cook 2003: 5–6). The work portrays Wellington’s 1813 victory over French forces at the Battle of Vitoria, depicting sounds of battle and ‘sampling’ national songs, such as ‘Rule Britannia’, ‘Malbrook’ (for the Napoleonic army) and ‘God Save the King’. For Beethoven’s audiences, this was affectively and politically charged; for example, E. T. A. Hoffmann tells of an officer gripping his sword during the piece’s battle sequence (ibid.: 16; see also Mathew 2007). Moreover, Beethoven and Mälzel’s collaboration was hardly unique. Earlier composers, including Haydn and Mozart, wrote for mechanical instruments, and Mälzel was often compared to the eighteenth-century inventor Jacques de Vaucanson, creator of a flute-playing android and an artificial duck. The age of classical music, then, was an age of automata and androids, of musical clocks and orchestra machines (Dolan 2013: 180–210; Voskuhl 2013; Loughridge 2016).

For all that, though, the panharmonicon version of *Wellingtons Sieg* was planned but never realised. Beethoven and Mälzel had a falling-out, and the piece was premiered by live orchestra, alongside the Seventh Symphony. This makes for an interesting reversal: instead of a mechanical arrangement of an orchestral original, it is effectively an orchestral arrangement of a mechanical original. The orchestra and the orchestra machine substitute for each other. As Emily Dolan (2013: 184) has argued, this juxtaposition can reveal how the orchestra itself is mechanical, a kind of complex technology that allows for the reproduction of musical works. Furthermore, this metaphor was already developed by eighteenth-century commentators. In 1783, Johann Nikolaus Forkel wrote, ‘The music of every orchestra is to be considered, with regard to its movement, as a clockwork’ (quoted in ibid.: 194).

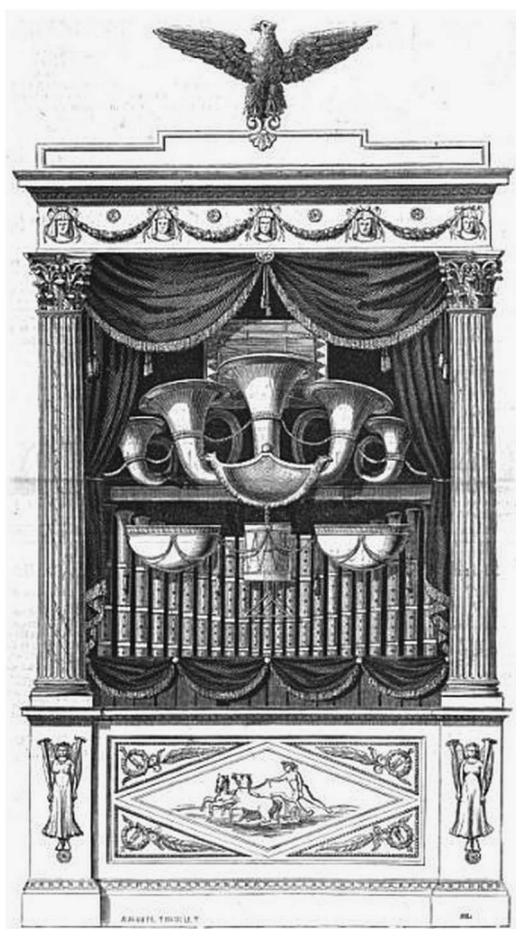

Figure 1. Johann Nepomuk Mälzel's panharmonicon, depicted in *L'illustration*, 25 May 1846.

This article juxtaposes historical orchestra machines and orchestras with contemporary network music systems. Examining their material particulars—but also their abstract topologies—offers an opportunity to reflect, more generally, on the interplay of music, technology and sociality. The article draws on and contributes to emerging discourse on instrumentality, increasingly referred to as ‘critical organology’. Such approaches combine the technical and historical study of instruments with more philosophical perspectives, including actor-network theory (Bates 2012), Foucauldian ethics (Tresch and Dolan 2013), media archaeology (Moseley 2016; Rehding 2016a, 2016b) and phenomenology (De Souza 2017). Such thinking approaches musical epistemology and ontology via musical technics. At the same time, insights from organology might illuminate broader ontological questions. Indeed, the philosopher and former IRCAM director Bernard Stiegler has called for a ‘general organology’. This would be a kind of inquiry, inspired by musical instrument studies, that would encompass three interconnected dimensions: ‘the body with its physiological organisation, artificial organs (techniques, objects, tools, instruments, artworks), and

social organisations resulting from the articulation of artefacts and bodies’ (Stiegler 2004: 23–4). ‘We must imagine a general organology,’ he argues, ‘that would study the conjoint history of these three dimensions of human aesthetics and the resulting tensions, inventions, and potentials’ (ibid.: 24). Because the orchestra has long been understood both as technology and as a model for society, it embodies links between the aesthetic, the technical and the political that are central to Stiegler’s thought. Like science, then, music is a rich domain for investigating the intertwining of the technical and the human.

2. ELECTROACOUSTIC ORCHESTRAS

There is no such thing as ‘the’ orchestra. Within Western classical music, orchestras have evolved alongside new instruments, concert spaces and musical institutions: Haydn’s orchestra, for example, differs substantially from Mahler’s. Furthermore, ‘orchestras’ are often found outside of the classical sphere – in jazz (e.g. the Count Basie Orchestra), progressive rock (the Trans-Siberian Orchestra), or various non-Western traditions (modern Chinese orchestras). Each kind of orchestra is a large instrumental ensemble, of course, but the significance of the term seems to go much further. It might recall aesthetic values or cultural prestige associated with the classical orchestra. In particular, it suggests that their music involves *orchestration*, a concept that emerged in the nineteenth century. Orchestration may be understood as a distinctive approach to instrumentation, involving the juxtaposition and development of varied timbres and textures, and pervasive re-orchestration of the same material (see Dolan 2013: 16). To call an ensemble an orchestra thus implies a mode of collective performance and associations with musical tradition, but also a certain aesthetic interest in sound itself.

Perhaps surprisingly, ‘orchestras’ are ubiquitous in twenty-first-century electroacoustic music; for example, the Princeton Laptop Orchestra (PLork), the Worldscape Laptop Orchestra, the Cybernetic Orchestra, The Machine Orchestra and the MICE Orchestra (Smallwood, Trueman, Cook and Wang 2008; Harker, Atmadjaja, Bagust and Field 2008; Vallis, Diakopoulos, Hochenbaum and Kapur 2012; Ogborn 2012; Burtner, Kemper and Topper 2012). Clearly, there are palpable differences between the computers that are central to these ensembles and the more traditional instruments of the orchestras just described (even the electric guitars and electronic keyboards of the Trans-Siberian Orchestra). As such, the term ‘laptop orchestra’ might be seen as ironic or poetic, as a way of highlighting those differences by juxtaposing the technological and the musical, the mundane and the highbrow. For composers and performers, however, the metaphor is also productive,

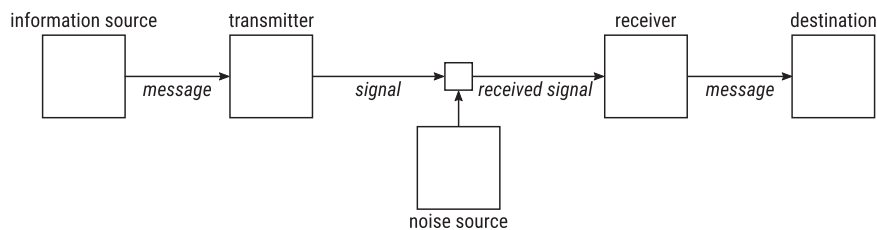

Figure 2. Claude Shannon's general communication system (Shannon 1964: 34).

insofar as it frames the ensemble's sonic and social affordances.

There are also substantial differences among these new orchestras, of course. In PLork, each player has a laptop that is connected to an individual speaker via a rack of audio equipment, meaning that 'each instrument is completely self-contained' (Smallwood et al. 2008: 10). This allows for a one-to-one relation between player and instrument, similar to that found in a conventional orchestra. The Machine Orchestra (TMO), by contrast, involves robotic instruments that are influenced by multiple players. Since individual players' actions pass through a central server, the system is conceptualised as 'a shared and social instrument' (Vallis et al. 2012: 63). This is analogous to four-hand piano music, where multiple players share a single instrument. Both of these ensembles vary their organisation for different pieces, and in both cases, the ensemble shares data via a network – wireless for PLork, and wired for TMO. The network facilitates communication and also coordination. Global synchronisation, for example, can be effected via the network, which would then function as a machine conductor. At the same time, PLork and TMO often use human conductors as well. These ensembles thus combine digitally encoded signals, shared by computers, with visual and gestural signals, shared by human participants.

Specific details of software and hardware constitute a set of affordances, or what the cognitive scientist David Kirsh calls an 'enactive landscape' (Kirsh 2013; see De Souza 2017: 52). Each system offers particular possibilities and constraints that shape actions, interactions, sounds or ideas. For example, PLork speakers cannot produce frequencies below 80 Hz, contributing to a distinctive 'PLork-sound' (Smallwood et al. 2008: 11). Yet it can also be illuminating to blackbox a system's components, strategically ignoring their inner workings and focusing instead on patterns of input and output. Drawing on information theory and cybernetics, this approach treats an ensemble as a kind of communication system. For the information theorist Claude Shannon, a communication system is a set of nodes and connections: it converts messages into signals that are transmitted to and decoded by a receiver, despite noisy interference (see Figure 2). The message might involve sound, text or images, and it might be

transmitted via wires, radio waves or some as-yet-undiscovered means. The system's structure, however, is not affected by such details. In other words, topological analysis, like cybernetics in general, deals with abstract machines and separates information from its necessary material substrate (see Hayles 1999). As a result, it cannot differentiate among systems that have isomorphic couplings, or distinguish between local networks and remote ones, which connect participants in distant locations (see Young 2001; Kapur, Wang, Davidson and Cook 2005). Still, complex network structures, with distinctive feedback loops or control pathways, can give rise to emergent properties that affect performers and audience alike. And as such, topology has been a concern for many practitioners and theorists of interactive musical networks (e.g. Barbosa 2003; Di Scipio 2003; Weinberg 2005).

Gil Weinberg (2005), for example, has theorised several kinds of musical network. His method proceeds from basic distinctions: a network can be centralised or decentralised, and its interaction can be synchronous or sequential.¹ Combining these two oppositions gives four basic network shapes. A flower topology is both centralised and synchronous, while a stair topology is decentralised and sequential (see Figure 3). Furthermore, each of these topologies may be connected sequentially or embedded in nodes of a larger network, allowing for a 'flower of stairs' or 'stair of flowers'. TMO's topology resembles an extended flower (Vallis et al. 2012: 65–6; see Figure 4). Each client is interconnected to the central hub, both sending and receiving messages; meanwhile, the hub sends output to the robotic instruments, which translate symbolic data into mechanical action and, ultimately, sound. The topology of Daniel Trueman's *The PLork Tree*, by contrast, resembles a series of forked stairs (Smallwood et al. 2008: 16–17; see Figure 5). Starting from the conductor (node 5), each node may pass musical data and text messages to two neighbours. The conductor has a unique position in the network, able to

¹Strictly speaking, the synchronous/sequential opposition can be reflected only in the *direction* of network connections, since, from a topological perspective, time is reduced to sequential order. It is puzzling, then, that Weinberg's sequential-network diagrams sometimes include two-way arrows that move against the indicated flow of time. As such, my adaptation of his stair network uses only one-way arrows.

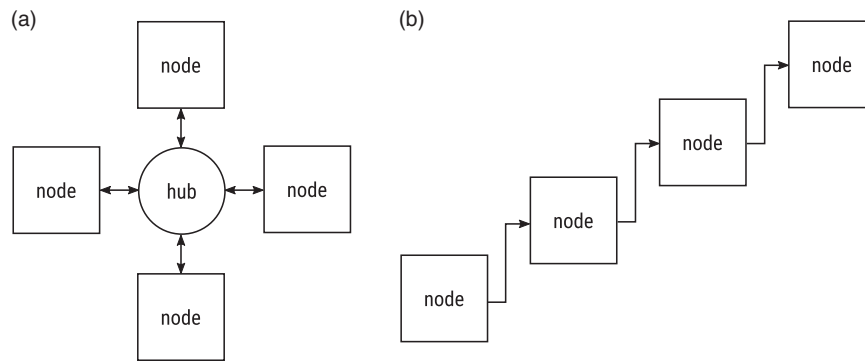

Figure 3. Two network topologies (adapted from Weinberg 2005): a) synchronous centralised network (flower topology); b) sequential decentralised network (stair topology).

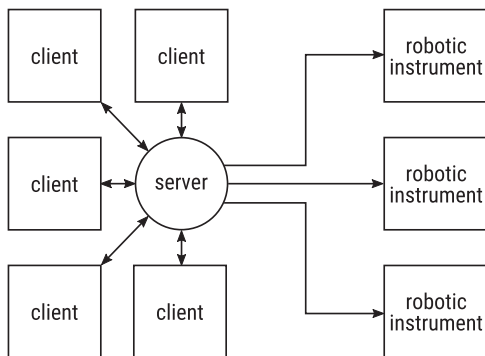

Figure 4. Network for *The Machine Orchestra* (adapted from Vallis et al. 2012).

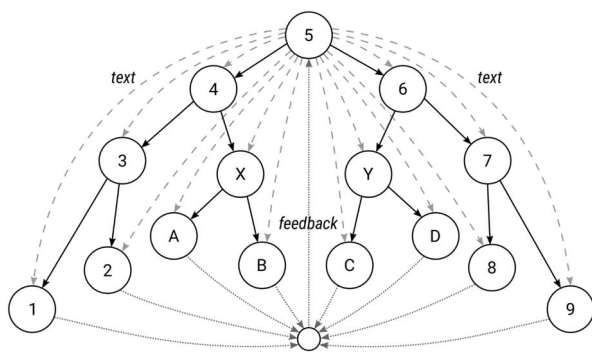

Figure 5. Network for *The PLork Tree* (adapted from Smallwood et al. 2008).

send text messages to any other player and to feed the final nodes' output back into the network. Nonetheless, the conductor cannot control other players' actions, resulting in 'an exciting sense of anarchy' (ibid.: 17). Weinberg (2005: 32–3) uses similar terms, contrasting 'anarchic' decentralised networks, with 'democratic' or 'monarchic' centralised ones.

Such sociopolitical metaphors are common in cybernetic thought (see Pickering 2010: 139–44). Yet they also recall historical discourses that consistently imagine the orchestra in social terms. Giuseppe Carpani's 1812

biography of Haydn, for example, anticipates Weinberg's discussion, contrasting the monarchic regimes of opera (where accompanying instruments are subject to the voice) with the more democratic organisation of the classical symphony – what Carpani calls a 'republic of different yet connected sounds' (quoted in Dolan 2013: 157). Modern orchestration, in this view, was a way of balancing individuality and collectivity, freedom and responsibility. 'Not only was the orchestra a society', Dolan explains, 'it was a society that had undergone a revolution' (ibid.). It follows that, insofar as a contemporary electroacoustic ensemble explores possibilities for interaction and control, it may be productively understood as a society of instruments – that is, as an orchestra.

3. CYBERNETIC ORGANOLGY

In both traditional and laptop orchestras, players and instruments are intimately linked. Their couplings can be imagined as mini-networks embedded in a larger network's nodes. Each node in *The PLork Tree*, for example, corresponds to a four-element chain: player–laptop–audio rack–speaker. Each node, then, can be understood as a kind of cyborg, a human–technology hybrid. A cybernetic ontology would refuse any strict division between the human and non-human here, and a cybernetic epistemology would claim that the system as a whole – not just the human within it – thinks, improvises and so forth. As Gregory Bateson (1972: 317) puts it, 'the computer is only an arc of a larger circuit which always includes a man and an environment from which information is received and upon which efferent messages from the computer have effect. This total system, or ensemble, may legitimately be said to show mental characteristics.' Or, indeed, musical characteristics.

Cybernetic ideas are obviously relevant to contemporaneous experiments in electroacoustic and computer music. But they were also applied in the seemingly traditional field of organology. Since the

nineteenth century, organology has involved taxonomic systems that categorise instruments in terms of the physics of sound production. For example, the Belgian organologist and instrument-maker Victor-Charles Mahillon – whose work influenced the better-known system of Erich von Hornbostel and Curt Sachs (1914, 1961) – produced scientific treatises on acoustics as well as comprehensive museum catalogues, which describe a range of Western and non-Western instruments (see Mahillon 1874, 1893). Yet organology, more generally, aims to understand what Herbert Heyde (2001: 4–6) calls ‘the dual nature of musical instruments’, as both physical and cultural objects. As Heyde emphasises, neither aspect explains the other, and thus organology must encompass both systematic and historical modes of investigation. The central section of Heyde’s *Grundlagen des natürlichen Systems der Musikinstrumente*, though, strategically brackets out the physics and history of instruments. Here he offers ‘an organological interpretation of central concepts of systems theory’, considering musical instruments as cybernetic systems (Heyde 1975: 22).

This approach focuses on ‘the energetic, material, and informational couplings between active elements’ (ibid.). An active element, for Heyde, must have at least one input and at least one output. Just as Shannon’s general communication system transmits signals that are ultimately converted into messages, Heyde’s instrumental systems transmit energy (e.g. mechanical or electrical energy) that is ultimately converted into musical sound (see De Souza 2017: 32–7). Again, the system’s structure depends on the overall pattern of inputs and outputs, not the elements’ material details. And crucially, these active elements may be either ‘anthropomorphic’ or ‘technomorphic’ (Heyde 1975: 22) – that is, human or non-human.

On the one hand, this approach can separate instruments that share a mode of sound production. The Hornbostel–Sachs system, for example, puts oboes and crumhorns in the same category (422.1), since they are both double-reed instruments. Heyde, however, argues that a crumhorn and an oboe have different informational structures, because the crumhorn player’s lips do not touch the reed:

The reed of a crumhorn ... has an input and an output: the input is air pressure at the opening of the reed and the output, in the reed canal, is a sound. The oboe reed, by contrast, has two inputs and one output. The air pressure at the opening of the reed is one input, the other is the damping pressure of the lips, and the output is a sound. (Ibid.: 22–3)

On the other hand, Heyde’s approach facilitates connections across instrumental categories, particularly when elements are considered in terms of functions. ‘For example,’ he writes, ‘all active elements that have the function of converting mechanical into acoustic energy belong to the class of transducers

Table 1. Instrumental functions (from Heyde 1975).

| Label | German term | English term | Examples |
|----------|--------------------------|-------------------------|---|
| A | <i>Anreger</i> | Activator | Muscles, clockwork, lungs, bellows |
| Ampl | <i>Amplifikator</i> | Amplifier | Electric guitar amp, loudspeaker |
| K | <i>Kopulator</i> | Coupler | Flute tube |
| M | <i>Modulator</i> | Modulator | Distortion pedal, electronic organ tone filter |
| MS | <i>Mengensteuerung</i> | Magnitude control | Organ swell pedal, volume knob, breath pressure |
| n | <i>nerval gesteuert</i> | Neurally controlled | |
| P | <i>programmgesteuert</i> | Program controlled | |
| R | <i>Resonator</i> | Resonator | Violin body, piano soundboard |
| Sch | <i>Schaltsteuerung</i> | Switch control | Organ keys |
| St | <i>Steuerelement</i> | Control element | Fingers, buttons |
| V | <i>Vermittler</i> | Intermediary | Violin bow, guitar pick, piano keys |
| W | <i>Wandler</i> | Transducer | Strings, membranes, reeds |
| ZS | <i>Zustandssteuerung</i> | State control | Piano damper pedal, harp pedals |
| ZW | <i>Zwischenwandler</i> | Intermediate transducer | Electric guitar pickup |
| [circle] | <i>Kanal</i> | Channel | Violin bridge, flutist’s throat |

(strings, membranes, reeds, etc.)’ (ibid.: 27). In this functional analysis, the oboe’s reed is equivalent to a string or drumhead.

Every instrument couples a transducer with an activator (energy source), and the simplest system includes only these elements. Yet Heyde also combines all of his functions in a general musical instrument system (see Table 1 and Figure 6). Theoretically, any real instrument can be represented as a subset of this elaborate network of functions. Here Heyde’s work resonates with W. Ross Ashby’s textbook on cybernetics, which explains that ‘cybernetics stands to the real machine – electronic, mechanical, neural, or economic – much as geometry stands to a real object’ (Ashby 1956: 2). Geometry, in this view, is not derived from real objects or shapes; instead, these are special cases of an all-encompassing geometry, which includes both real and imaginary objects. ‘Cybernetics is similar in its relation to the actual machine’, Ashby continues. ‘It takes as its subject-matter the domain of “all possible machines”, and is only secondarily interested if informed that some of them have not yet been made ... What cybernetics offers is the framework on which all individual machines may be ordered, related, and

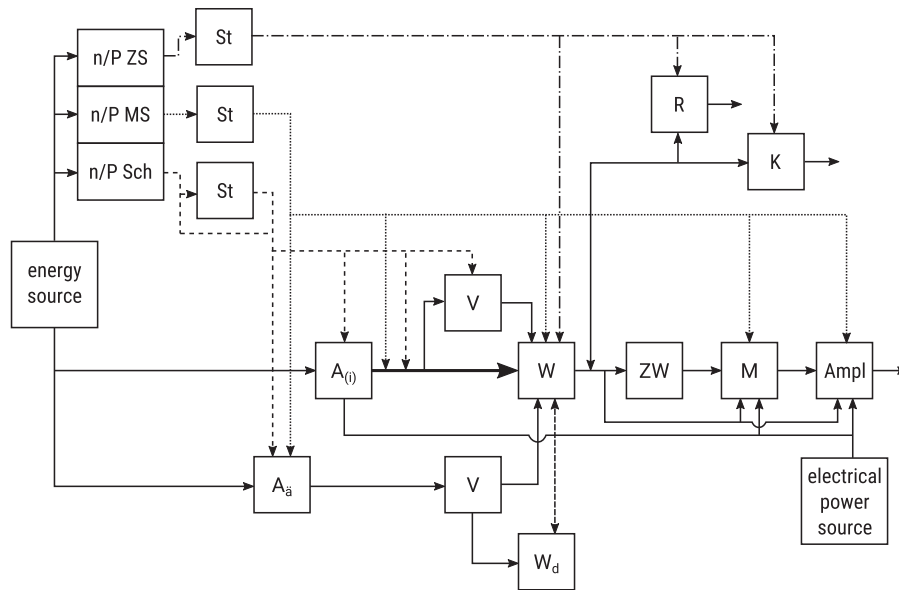

Figure 6. General musical instrument system (adapted from Heyde 1975: 62). For abbreviations, see Table 1. Additionally, Heyde annotates certain elements with subscripts: A_i stands for internal activator (*Anreger für innere*), A_a for external activator (*Anreger für äußere*) and W_d for double transducer (*Doppelwandler*).

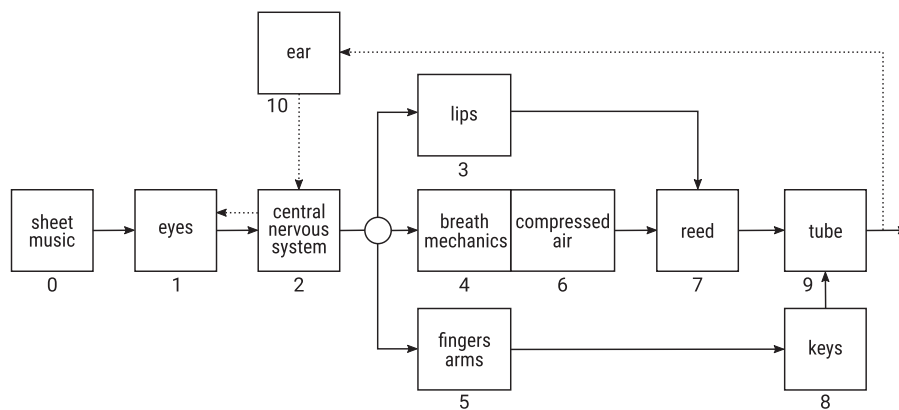

Figure 7. Circuit diagram for oboe playing (adapted from Heyde 1975: 24).

understood' (ibid.). Likewise, Heyde's system is oriented towards all possible musical instruments.

Heyde is also interested in particular instruments, though, and like Weinberg and other electroacoustic music practitioners, he represents them via network diagrams. For example, his diagram for the oboe is reproduced in Figure 7. This figure represents the couplings within the oboe – the reed (7), keys (8) and tube (9). But it also includes aspects of the players' body (1–5), including a feedback loop through the ear (10). 'From this perspective', writes Heyde (1975: 25), 'the player and instrument represent a control circuit.' Both the oboe and the player are only subsystems (ibid.: 26). (Later networks in the book illustrate this by shading the anthropomorphic nodes.) Each system is also situated in a broader environment: its final output is sound; its original input, musical notation.

Twentieth- and twenty-first-century developments might be understood to add a 'post-human' twist to

such systems, rendering instrumentalists superfluous. Consider the sound installation *Sustainable*, created by David Birchfield, David Lorig and Kelly Phillips (2005). Like TMO, *Sustainable* involves robotic instruments (in this case, robotic water gongs); like *The PLork Tree*, it instantiates a sequential network with a feedback loop (see Figure 8). Its creators also explicitly conceive of the network as a sociopolitical metaphor, using the piece to explore issues around water resources (ibid.: 268). Yet *Sustainable* requires no human players and thus seems more difficult to imagine as an orchestra. The installation, once started, is governed by algorithms. It functions as an autonomous cybernetic system.

Still, Heyde already recognises limit cases of instrumental systems with no anthropomorphic elements (or no technomorphic ones, as in whistling). These possibilities simply follow from the interchangeability of anthropomorphic and technomorphic elements that

cybernetics posits. Hands can replace drumsticks; bellows can replace lungs. As the actor-network theorist Bruno Latour argues, networks of human (H) and non-human (NH) agents involve not only *association* but also *substitution* (Latour 1991: 106). Here Heyde’s main example is a historical one: Vaucanson’s flute-playing android from 1738 (see Figure 9). The android is an interesting case of substitution, since it attempts to reproduce not just the effects but also the causal mechanics of flute playing. It covers the flute’s finger holes with mechanical fingers and blows across the embouchure hole with mechanical breath. For Jessica Riskin (2003: 610), ‘the most striking feature of Vaucanson’s automata [is] their simultaneous enactment of both the sameness and the incomparability of life and machinery’. Since the early eighteenth century, she argues, concepts of the machine and the human have been dialectically entwined (ibid.: 623). Substitution, then, has diverse effects, introducing changes that are often unexpected. It is not that certain elements – whether human or technological – remain exactly the same, while others vary. Instead, to some degree, ‘all the actors co-evolve’ (Latour 1991: 117, emphasis

original). For Stiegler (2009: 80–1), this is at the heart of a philosophical organology – not asking how machines can imitate or reproduce human capabilities (‘Can machines think?’), but asking how the human and the technological transform each other.

With the substitution of a robotic player for a human one, the boundaries of the instrument – already porous in Heyde’s account – might open further. Instrument and ‘performer’ seem more likely to merge. *Sustainable*, for example, seems non-orchestral not only because of the homogeneity of its timbre but also because of the homogeneity of its technological agents. Its creators describe the water gongs as autonomous, agentive ‘players’. ‘Each gong acts selfishly and independently’, they write, ‘either purging or conserving water to achieve its target’ (Birchfield et al. 2005: 269). *Sustainable* does not necessarily lack players, then, though it does seem to lack player–instrument interaction. Arguably it would seem more orchestral if each gong were described as an instrument played *by* a beater–water-control system, or if each gong were played by an android. It all comes down to the opposition but also binding of player and instrument, which is both revealed and problematised by cybernetic organology – a dialectic that is central to both historical and contemporary orchestral aesthetics.

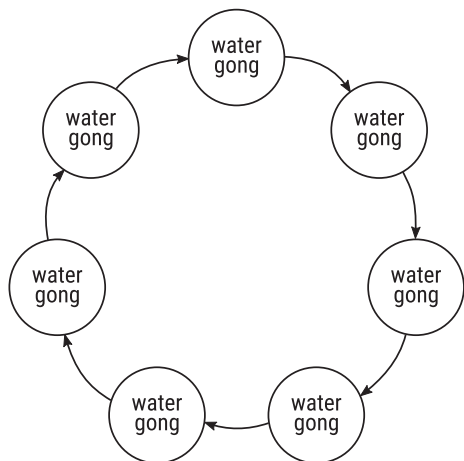

Figure 8. Network for *Sustainable* (adapted from Birchfield et al. 2005).

4. ORCHESTRA MACHINES

4.1. The panharmonicon

The panharmonicon involves this interplay of association and substitution too. The name ‘panharmonicon’ was used for both musical automata and keyboard instruments (Dolan 2013: 191–4). The meaning of ‘orchestron’ was similarly fluid: in 1789, Abbé Vogler coined the term for his newly invented piano–organ hybrid, but in the nineteenth century it came to be associated with orchestra machines (ibid.: 186–7). Either way, such instruments were understood in orchestral terms (even as they affected ideas about orchestral mechanics). They offered timbral variety, of

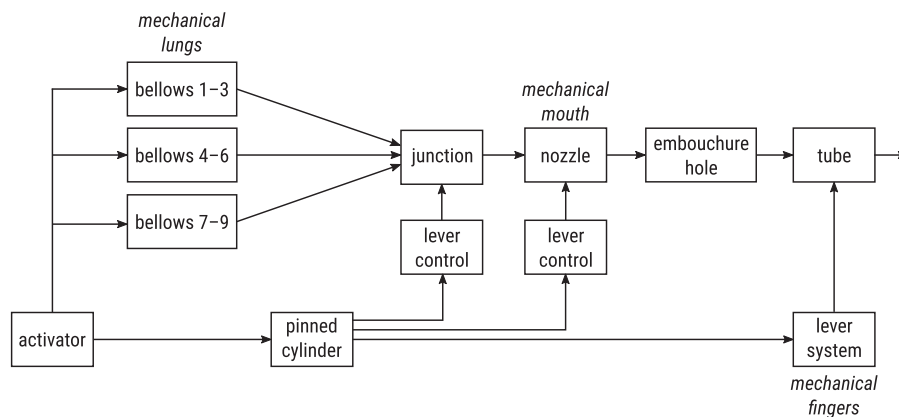

Figure 9. Network for Vaucanson’s flute-playing android (adapted from Heyde 1975: 26).

course. But like later synthesisers, they were also understood to recreate the timbres of specific orchestral instruments.² The *Berlinische musikalische Zeitung* claimed that the panharmonicon was so realistic that ‘one should truly believe that one is hearing a good orchestra’ (Wolf 2012: 300). In 1840, another commentator described the panharmonicon as ‘an automaton or rather a true musical instrument that mimics a complete orchestra with timpani and trumpets, drums, and triangles, activating the real instruments installed within it through a barrel and bellows’ (ibid.: 325).

These ‘real instruments’ were understood to distinguish the panharmonicon from the organ. The Parisian *Journal de l’empire*, for example, described it as an instrument that perfected and surpassed the organ (ibid.: 300). Like Joseph Gurk’s 1810 panharmonicon, Mälzel’s machine contained a multiplicity of woodwind and brass instruments, each tuned to produce a single, unchanging note. In other words, it included banks of trumpets and clarinets. Like Vaucanson’s flute-playing android, the panharmonicon mechanically imitated traditional modes of sound production – for example, simulating trumpeters’ lips and breath. (This replicated the central innovation of Mälzel’s trumpet-playing android, without its human form and military costume.) Though Mälzel’s first panharmonicon lacked strings, his later version – the one for which Beethoven composed *Wellingtons Sieg* – covered the whole orchestra: flutes, clarinets, oboes and bassoons, trumpets, horns, trombones, violins and cellos, timpani, drums and triangle. As an orchestra machine (rather than a mechanical organ), these were conceptualised as *separate* instruments.

At the same time, these separate instruments are necessarily *coordinated*, and this coordination is achieved via pinned cylinders. Like the punched paper rolls used by player pianos or mid-twentieth-century synthesisers, a pinned cylinder represents a musical code that is meant to be *run*, not decoded (Moseley 2016: 11). As Carolyn Abbate puts it, it is ‘a material trace of the musical work, yet not a score (a symbolic prescription for the work’s realisation) and not a gramophonic impression of the work’s sound (a recording)’; it is a place ‘within the machine where notation and fingers can become one’ (Abbate 1999: 485–6). Though the panharmonicon and other orchestra machines are arguably haunted by ghostly fingers, their cylinders may also be understood as places where notation and *conductor* become one. From this perspective, the cylinder directs an instrumental ensemble from within the machine, somewhat like the man hidden inside the fraudulent chess automaton, who moves

and coordinates the pieces on the board. In Weinberg’s terms, the cylinder would be a server in a centralised flower network. The cylinder stores the program; it is the source of information and control in the system. The panharmonicon’s instruments are coordinated then, but only indirectly, via the mediation of the score-conductor.

This reveals another dimension to orchestral association: player–instrument coordination is supplemented by player–player or instrument–instrument coordination. Both dimensions seem important to orchestral systems. For example, Scott Smallwood’s *On the Floor* – a musical game for PLork – is described as an ‘anti-orchestra piece’, ‘because it does not present musicians with an instrument that they must master, nor are the musicians members of an ensemble with which they must blend and interact’ (Smallwood et al. 2008: 21). More generally, though, this interplay suggests that there is no essential difference between instrument and ensemble. This slippage is particularly clear with the panharmonicon, which seems poised between the two concepts. But like a figure–ground reversal, the switch is always possible: an ensemble may be reimagined as a single macro-instrument, or a single instrument, as a miniature ensemble. According to Anton Rubinstein, for example, the piano is ‘not just one instrument – it is a hundred’ (quoted in Makelberge 2012: 30). A circuit might involve multiple players operating a single instrument (as in four-hand piano playing), a single player operating multiple instruments (as in a ‘one-man band’), or multiple players operating multiple instruments. The basic energetic, material and informational couplings, along with Heyde’s function classes, remain the same. This recalls Latour’s attempt to challenge the society/technology divide: ‘Of course, an H–H–H assembly looks like social relations while a NH–NH–NH portion looks like a mechanism or a machine’, he writes, ‘but the point is that they are always integrated into longer chains’ (Latour 1991: 110). If society and technology are not ontologically distinct, if they represent interchangeable perspectives on relationality, then it is no surprise that orchestras, old and new, are imagined in both social and mechanical terms.

4.2. Orchestral networks

So, what sort of network is the orchestra – that is, the traditional, conventional or acoustic orchestra? How does information flow through this system? How are its active elements connected? What does its topology look like?

To start, an orchestra can be understood as a ‘large-scale local system’ (Weinberg 2005: 30). Such systems have more than ten players, meaning that a sizeable string section would count as a large-scale system on its own. As the size of the system increases, strategies for

²As I have discussed elsewhere, synthetic imitations of instrumental timbres emerge as early as 1858, with Hermann von Helmholtz’s electromagnetic tuning-fork apparatus (De Souza, forthcoming).

coordination become increasingly important. ‘Here, the details and subtleties of individual contributions are often hidden by the large quantities of participants’, Weinberg writes. ‘The central system, therefore, often focuses on analysing the large-scale group interaction patterns and coordinating the multiple input sources into a meaningful musical outcome’ (ibid.). This central system is typically a conductor. Through gestural signals, the conductor may be understood to shape the sound – as in expressive tempo variation – or to provide feedback (e.g. when the ensemble or a particular part within it is too loud or too soft). In terms of visual information flow, the conductor is in a unique position: all players can look at the conductor, though they mostly cannot see each other. While the panharmonicon’s cylinder controls disconnected mechanical instruments, the conductor helps to coordinate instrumentalists who can hear each other. Of course, in certain environments, this auditory feedback can be misleading, and players must rely on the visual modality. Still, sonic connections among players make it possible to decentralise the network – as in numerous ‘conductorless orchestras’, including early orchestras directed from the keyboard or the concertmaster’s chair. In principle, the network among players has a symmetrical topology, as every player can potentially hear every other. Still, it should also be weighted, since certain colleagues are easier to hear than others (ibid.: 36).

While conductors and sonic feedback facilitate temporal and dynamic coordination, the score and parts dictate specific pitches and rhythms. Following Heyde, parts may be understood as an important source of input for the orchestral system. Notation, obviously, is also quasi-centralised and is essential to the orchestra’s function as a ‘recording technology’, a kind of machine for reproducing musical works. Dolan (2013: 200) emphasises that orchestras could make sonic effects repeatable, effects that influenced listeners at a bodily level. For performers, however, parts also choreograph repeatable physical actions. Identical parts can especially support player–player coordination within instrumental groups. A section violist coordinates bowing, fingering, dynamics and so on with fellow section members – and particularly with the principal, who can function as a kind of local hub. The viola section strives for entrainment, sonically but also kinaesthetically. To this end, they supplement their parts, pencilling in bowing marks, finger numbers and a variety of symbols – eyeglasses (a reminder to look at the conductor), squiggles or arrows above the staff (for *ritardandi* and *accelerandi*), the letters V. S. (for quick page turns), a kind of E on its side (which represents a mute) and so forth.

Such markings make the part more informative, but they also reflect usually unspoken conventions of orchestral behaviour. At a first rehearsal with new colleagues, without discussing it beforehand, the violists sitting on the inside turn pages and take the bottom line

in divisi passages. The relative stability of such conventions is essential to the orchestra’s consistent playback. Stabilisation, for Latour, makes the social appear as technological. That is, when agents start to work in predictable ways, a network is more likely to be viewed as a technology. Aphoristically, ‘technology is society made durable’ (Latour 1991). From this perspective, musicians’ everyday habits, along with relatively stable instruments and notational conventions, help make the orchestra a reliable system for realising musical works. The orchestra can function as a playback machine, because of stabilisation of both techniques and tools, because of consistent informational couplings or exchanges. From this perspective, control – for example, the control ceded to a conductor or composer – is an effect, not a cause (see ibid.: 130). It co-evolves with – and is made possible by – particular sociotechnical relations in a network of players and instruments.

5. CONCLUSIONS

Panharmonicons and orchestrions, whether played or automatic, represent a trend in the history of instruments that, for Nicolas Makelberge, culminates in contemporary digital technologies: ‘New instruments ... allowed users to achieve musical products that previously demanded a collective’ (Makelberge 2012: 28). In this account, substitution and technical mediation facilitate compositional autonomy. For example, a solitary musician can use Apple’s Logic Pro to realise a full orchestral score (see Tresch and Dolan 2013: 279–80). Yet orchestras and large-scale networks also reflect an opposing trend. These systems facilitate the coordination or control of ever-larger groups, across ever-greater distances. Orchestral output can also support cooperation with listeners, singers or dancers (whether ballerinas onstage or waltzing audience members). Of course, one side looks like technological development; the other, like social development. But, this article argues, technological and social dynamics in music are not easily separated.

Considering the network as orchestra and the orchestra as network sets up a dialogue between present and past, between music and technology. This inquiry is fundamentally organological in Stiegler’s sense, encompassing human physiology, cultural artefacts and social organisation. Insofar as instruments communicate with human bodies, the study of musical technology includes corporeal technique; insofar as instruments and players are arranged in ensembles, it expands to social organisation as well. Player–instrument interaction and player–player coordination, then, are profoundly intertwined. Ultimately, this organology helps reveal links between the aesthetic, the technical and the political.

With all three domains, the networks discussed throughout this article are not neutral, and that raises

ethical questions. How might we evaluate the social formations that they realise? How can we assess what Georgina Born (2012: 267), invoking Gilles Deleuze and Félix Guattari (1987: 235), calls the ‘micropolitics’ of musical performance and practice? These are complex questions, difficult to answer in general terms. Some might prefer ‘democratic’ networks, which aim to balance individual agency and collective interrelation. Others might prefer the freedom offered by ‘anarchic’ networks, following John Cage’s claim that ‘musicians can do without government’ (Cage 1979: 183). Yet perhaps the most politically significant feature of these ensembles is their contingency, their changeability. After all, if social relations were fixed and predetermined, politics would be impossible (see Latour 2005: 250). Orchestras of various types can expand, contract or re-organise. Their flexibility, then, parallels music’s ‘capacity to destabilize and re-orchestrate ... criteria of belonging and affiliation, and therefore new collective solidarities’ (Born 2012: 267). At the same time, Deleuze and Guattari (1987: 237) warn that supple, local or new connections do not necessarily make anything ‘better’, and even organisations with a progressive macropolitics, they suggest, can harbour microfascisms. Orchestras and orchestra machines, then, offer no ethical or political guarantees. But they might afford a kind of aesthetic-political play, framing the social as a field that can be made and remade. On this level, they let us explore social formations – centralised or decentralised, stable, fragile or revolutionary – that we might wish to compose.

Acknowledgements

I wish to thank Erika Honisch, Margaret Schedel and the journal’s anonymous reviewers. Unless cited otherwise, all translations are mine.

REFERENCES

- Abbate, C. 1999. Outside Ravel’s Tomb. *Journal of the American Musicological Society* 52: 465–530.
- Ashby, W. R. 1956. *An Introduction to Cybernetics*. London: Chapman & Hall.
- Barbosa, A. 2003. Displaced Soundscapes: A Survey of Network Systems for Music and Sonic Art Creation. *Leonardo Music Journal* 13: 53–59.
- Bates, E. 2012. The Social Life of Musical Instruments. *Ethnomusicology* 56: 363–95.
- Bateson, G. 1972. *Steps to an Ecology of Mind*. New York: Ballantine Books.
- Birchfield, D., Lorig, D. and Phillips, K. 2005. Network Dynamics in *Sustainable*: A Robotic Sound Installation. *Organised Sound* 10: 267–74.
- Born, G. 2012. Music and the Social. In M. Clayton, T. Herbert and R. Middleton (eds.) *The Cultural Study of Music: A Critical Introduction*, 2nd edn. New York: Routledge.
- Burtner, M., Kemper, S. and Topper, D. 2012. Network Socio-Synthesis and Emergence in NOMADS. *Organised Sound* 17: 45–55.
- Cage, J. 1979. *Empty Words: Writings ’73–’78*. Middletown, CT: Wesleyan University Press.
- Cook, N. 2003. The Other Beethoven: Heroism, the Canon, and the Works of 1813–14. *19th-Century Music* 27: 3–24.
- Deleuze, G. and Guattari, F. 1987. *A Thousand Plateaus: Capitalism and Schizophrenia*. trans. B. Massumi. Minneapolis: University of Minnesota Press.
- De Souza, J. 2017. *Music at Hand: Instruments, Bodies, and Cognition*. New York: Oxford University Press.
- De Souza, J. forthcoming. Timbral Thievery: Synthesizers and Sonic Materiality. In A. Rehding and E. I. Dolan (eds.) *The Oxford Handbook of Timbre*. New York and Oxford: Oxford University Press.
- Di Scipio, A. 2003. ‘Sound is the Interface’: From *Interactive* to *Ecosystemic* Signal Processing. *Organised Sound* 8: 269–77.
- Dolan, E. I. 2013. *The Orchestral Revolution: Haydn and the Technologies of Timbre*. Cambridge and New York: Cambridge University Press.
- Harker, A., Atmadjaja, A., Bagust, J. and Field, A. 2008. Worldscape Laptop Orchestra. *Proceedings of the International Computer Music Conference*. Belfast: ICMA.
- Hayles, N. K. 1999. *How We Became Posthuman: Virtual Bodies in Cybernetics, Literature, and Informatics*. Chicago and London: University of Chicago Press.
- Heyde, H. 1975. *Grundlagen des natürlichen Systems der Musikinstrumente*. Leipzig: VEB Deutscher Verlag für Musik.
- Heyde, H. 2001. Methods of Organology and Proportions in Brass Wind Instrument Making. *Historic Brass Society Journal* 13: 1–51.
- Hornbostel, E. M. von and Sachs, C. 1914. Systematik Der Musikinstrumente: Ein Versuch. *Zeitschrift Für Ethnologie* 46: 553–90.
- Hornbostel, E. M. von and Sachs, C. 1961. Classification of Musical Instruments. *The Galpin Society Journal* 14: 3–29.
- Kapur, A., Wang, G., Davidson, P. and Cook, P. R. 2005. Interactive Network Performance: A Dream Worth Dreaming? *Organised Sound* 10: 209–19.
- Kirsh, D. 2013. Embodied Cognition and the Magical Future of Interaction Design. *ACM Transactions on Computer-Human Interaction* 20: 3.
- Latour, B. 1991. Technology is Society Made Durable. In J. Law (ed.) *A Sociology of Monsters: Essays on Power, Technology, and Domination*. London and New York: Routledge.
- Latour, B. 2005. *Reassembling the Social: An Introduction to Actor-Network-Theory*. Oxford: Oxford University Press.
- Loughridge, D. 2016. *Haydn’s Sunrise, Beethoven’s Shadow: Audiovisual Culture and the Emergence of Musical Romanticism*. Chicago: University of Chicago Press.
- Mahillon, V.-C. 1874. *Éléments d’acoustique musicale et instrumentale*. Brussels: Mertens.
- Mahillon, V.-C. 1893. *Catalogue descriptif et analytique du Musée instrumental du Conservatoire royal de musique de Bruxelles*, 2nd edn. Brussels: T. Lombaerts.
- Makelberge, N. 2012. Rethinking Collaboration in Networked Music. *Organised Sound* 17: 28–35.
- Mathew, N. 2007. History Under Erasure: Wellingtons Sieg, the Congress of Vienna, and the Ruination of Beethoven’s Heroic Style. *The Musical Quarterly* 89: 17–61.

- Moseley, R. 2016. *Keysto Play: Music as a Ludic Medium from Apollo to Nintendo*. Oakland: University of California Press.
- Ogborn, D. 2012. Composing for a Networked, Pulse-Based, Laptop Orchestra. *Organised Sound* **17**: 56–61.
- Pickering, A. 2010. *The Cybernetic Brain: Sketches of Another Future*. Chicago: University of Chicago Press.
- Rehding, A. 2016a. Instruments of Music Theory. *Music Theory Online* **22**. <http://mtosmt.org/issues/mto.16.22.4/mto.16.22.4.rehding.html> (accessed 2 May 2018).
- Rehding, A. 2016b. Three Music-Theory Lessons. *Journal of the Royal Musical Association* **141**: 251–82.
- Riskin, J. 2003. The Defecating Duck, Or, The Ambiguous Origins of Artificial Life. *Critical Inquiry* **29**: 599–633.
- Shannon, C. E. 1964. The Mathematical Theory of Communication. In C. E. Shannon and W. Weaver *The Mathematical Theory of Communication*. Urbana: University of Illinois Press.
- Smallwood, S., Trueman, D., Cook, P. R. and Wang, G. 2008. Composing for Laptop Orchestra. *Computer Music Journal* **32**: 9–25.
- Stiegler, B. 2004. *De la misère symbolique 1. L'époque hyperindustrielle*. Paris: Editions Galilée.
- Stiegler, B. 2009. *Technics and Time 2: Disorientation*. trans. S. Barker. Stanford: Stanford University Press.
- Tresch, J. and Dolan, E. I. 2013. Toward a New Organology: Instruments of Music and Science. *Osiris* **28**: 278–98.
- Vallis, O., Diakopoulos, D., Hochenbaum, J. and Kapur, A. 2012. Building on the Foundations of Network Music: Exploring Interaction Contexts and Shared Robotic Instruments. *Organised Sound* **17**: 62–72.
- Voskuhl, A. 2013. *Androids in the Enlightenment: Mechanics, Artisans, and Cultures of the Self*. Chicago: University of Chicago Press.
- Weinberg, G. 2005. Interconnected Musical Networks: Toward a Theoretical Framework. *Computer Music Journal* **29**: 23–39.
- Wolf, R. 2012. *Die Musikmaschinen von Kaufmann, Mälzel und Robertson: Eine Quellenedition*. Munich: Deutsches Museum.
- Young, J. P. 2001. Networked Music: Bridging Real and Virtual Space. *Organised Sound* **6**: 107–10.