

Self-intervening Networks

21.1 Introduction

In this chapter, we discuss some of the differences between apparatus and systems under observation (SUOs). The discussion is phrased in terms of *self-intervening networks*, wherein partial quantum outcomes in an early stage of an apparatus can alter future configurations of that apparatus.

To explain what we mean, we introduce the following classification of experiments. Note that reference to *apparatus* here includes real and virtual detectors, and real and virtual modules. Virtual detectors and modules are mathematical fictions that are introduced into the formalism for convenience.

Type-Zero Experiments

Many important experiments involve signal propagation through “empty space.” We classify these as type zero (T0). The feature of T0 experiments qualifying for this classification is that the observer has no control of the modules in the information void. Examples are experiments in astrophysics, where the observer can choose which source to observe and how they observe it, but has no influence on the physical properties of whatever lies between source and detector. If there are gas clouds between source and detector, the observer can only recognize that fact after the experimental data are analyzed. An important modern variant of T0 experiments involves map location via the Global Positioning System (GPS): signals sent from Earth to geostationary satellites and received by mobile devices back on Earth have traveled through Earth’s atmosphere and through empty space, where special relativistic and general relativistic effects have to be taken into account (Ashby, 2002).

Before the rise of experimental science, most “experiments” were based on visual observations, which are principally of T0 classification. The advent of the telescope and the microscope did not change things in this respect. Indeed, it has been suggested that science did not progress in antiquity precisely because of the philosophical principle that the only valid experiments could be of T0, as

these do not introduce the artificiality of constructed modules into observation, which (it was argued) would give a false perspective on “reality.” The logic of that argument is superb, but it is a dead-end principle in science.

Several sciences such as geology, archaeology, and, indeed, cosmology started off with periods of basic observation rather than experimentation. During such initial stages of these sciences, the observations could be classified as T0 experiments. In mechanics, the apocryphal dropping by Galileo of two spheres of different mass from the Leaning Tower of Pisa can be classified as of type T0.

Type-One Experiments

Many quantum experiments involve time-independent modules, introduced by an observer into an information void, which appear to persist unchanged in the laboratory over the course of each run of an experiment. By this we mean that for each run of such an experiment, the apparatus that prepares the initial state, shields it from the environment during that run, and detects the outcome state is considered fixed during each stage of a run. In other words, such apparatus persists over time scales significantly greater than the time scale of each run. We classify such experiments as *type one* (T1). These differ from T0 experiments in that the observer explicitly introduces real modules, such as beam splitters and mirrors, into the information void.

The illusion of persistence is a convenient mental device, because all experiments are done in process time and everything changes. However, the concept of persistence is a potent and necessary one that is needed to make sense of what science is all about. It is formalized in quantized detector networks (QDN) by the use of null evolution, as discussed in Section 7.11 and Chapter 18. In standard quantum mechanics (QM), T1 experiments are described in terms of time-independent Hamiltonian operators in Schrödinger equations.

In practice, all experiments have some degree of T1 behavior. For instance, the very action of constructing apparatus before an experiment starts carries the hidden assumption that the constructed apparatus will persist long enough to be useful. That assumption has some amusing aspects. For example, no one would consider constructing parts of their apparatus out of ice, unless the environment made that feasible, as in the Antarctic.

In quantum optics, the double-slit (DS) experiment, Mach–Zehnder interferometer experiments, and quantum eraser experiments (Walborn et al., 2002) are all of this type. So too are high-energy particle-scattering experiments such as those conducted at the Large Hadron Collider at CERN.

After T0, T1 experiments are technically the easiest to construct, and many historical experiments were of this type. T1 experiments allow the focus of attention to be entirely on the dynamical evolution of the states of an SUO, because such states are conventionally regarded as the only objects of interest in physics.

Type-Two Experiments

An important class of experiment, referred to here as *type two* (T2), involves some time dependence in the apparatus that is controlled by factors external to the apparatus, either by the observer directly or by factors external to the laboratory. When controlled by the observer, such experiments require a more advanced technological level than in T1 experiments, such as advanced electronics and computerization. In standard quantum mechanics (QM), T2 experiments are described in terms of time-dependent Hamiltonian operators in Schrödinger equations.

Spin-echo magnetic resonance experiments are of this type, because the experimentalist arranges for certain magnetic fields to be rotated precisely, while additionally, the sample environment introduces random external influences related to local temperature. An example of random changes controlled by the experimentalist are the delayed-choice experiments such as that of Jacques et al. (2007), discussed in Section 14.5, where carefully arranged random changes are made during each run. QM typically describes such experiments via time-dependent Hamiltonian that may have stochastic elements.

T2 experiments are always going to be more interesting than T1 experiments for two reasons: T1 experiments can be regarded as limiting cases of T2 experiments where time dependence is turned off, and because T2 experiments have the potential to reveal more information about the dynamics of systems under observation than T1. Schwinger's source theory in relativistic quantum field theory shows that, in principle, T2 experiments allow for the extraction of all possible information about quantum systems (Schwinger, 1969, 1998a,b,c).

T1 and T2 experiments may be collectively labeled as *exophysical*, because they involve classical apparatus interventions that are external in origin to the SUO. In such experiments, the apparatus is classically well defined at each instant of time during each run, even in those situations where it changes randomly. Therefore, a classical Block Universe (Price, 1997) account of apparatus during each run of a T1 or T2 experiment may be possible.

Type-Three Experiments

In this chapter, we explore a third type of quantum experiment, referred to as *type three* (T3). In such an experiment, the apparatus is modified internally by the quantum dynamics of the SUO, rather than externally by the observer or the environment.

There is an interesting point to be made here about experiments conducted at high-energy particle-scattering laboratories such as the Large Hadron Collider (LHC). Such experiments have fixed sources and detectors and do not have real, physical modules in the interaction region. From that perspective they are T0 experiments. However, the observers can arrange for their particle beams to intersect and allow particle collisions, so from that perspective, such experiments are of type T1. However, the interactions that occur are entirely quantum processes,

so they are of also type T3 in an essential way. Indeed, that is the whole point of such experiments.

In Chapter 25 we discuss such experiments as processes where virtual modules are created in the information void by the dynamics of the SUOs. For example, two-particle to two-particle scattering amplitudes discussed in high-energy particle physics have all the characteristics of beam splitters.

Type-Four Experiments

In recent years, there has been interest in experiments that contain T2 and T3 aspects. We have in mind experiments of the Elitzur–Vaidman bomb-tester variety, discussed in Chapter 25. Such experiments can be classified as *type-four* (T4) experiments

A question that we address toward the end of this chapter is whether T3 experiments can always be given a classical Block Universe account or whether something analogous to superpositions of different *apparatus* has to be envisaged. This is not to be confused with the superposition of labstates that we have discussed up to now.

This question is related to the rules of quantum information extraction as they are currently understood in QM. These rules state that quantum interference can occur in the absence of classical which-path information, the most well-known example of this being the DS experiment.

The question here is what precisely does a lack of which-path information mean? *If* such as thing as a photon actually passed through one of the slits, would it leave any trace in principle? Even if it did, it would have to be essentially unobservable, at least far below the scales of classical mechanical detection. In that case, an observer of the interference pattern would indeed be unaware of such an interaction. In essence, such a scenario would be welcomed by supporters of the Hidden Variables (HV) interpretation of empirical physics.

This supposition seems wrong to us for the following reason. In the DS experiment, there are three cases: (1) a photon actually goes through one of the slits but leaves no trace whatsoever; (2) a photon actually goes through one of the slits and leaves a trace that cannot be detected; or (3) we avoid the use of the photon concept.

Our inclination is to discount case 1 on the grounds that any assertion that something “exists” or has occurred, but no evidence for it can ever be found, is vacuous and can be dismissed by Hitchens’ razor.¹

As for case 2, the idea that it is the mere lack of suitable photon-slit interaction detection technology itself that produces interference patterns on a remote screen seems be wrong on two counts. First, there is now sufficient evidence against the

¹ “What can be asserted without evidence can be dismissed without evidence,” a modern version of the Latin proverb “*Quod gratis asseritur, gratis negatur*” (what is freely asserted can be freely deserted).

notion that photons are particles in the conventional sense (Paul, 2004). Second, the idea that interference patterns could occur when one observer was unaware of actual which-path information while another observer was aware of it seems inconsistent.² It seems likely that there has to be something deeper in the origin of quantum interference. We do not believe it lies in the hidden variables direction because of its contextual incompleteness.

Neutron interference experiments (Greenberger and YaSin, 1989) explore this question in that they are moving toward larger scales of interaction between SUOs and apparatus. In their experiment, the movement of mirrors involved in their quantum erasure scheme involves macroscopic numbers of atoms and molecules (Becker, 1998). In this case, the dynamical effects of the impact of a particle on a mirror is reversed by a second impact. What is amazing is the idea that all possible traces of the first impact could be completely erased, even though there could (in principle) be time for information from the first impact to be dissipated into the environment, thereby rendering the process irreversible.

This raises the question of what irreversibility actually means. Is a process irreversible in some absolute sense, or is it contextual and dependent on the observer? We have previously suggested that there are no absolutes in physics. Therefore, we should examine the possibility that what is irreversible to one observer need not be irreversible to another. This does not seem inconsistent or unreasonable, given that irreversibility and observers are emergent processes, the laws of which have not yet been understood in any significant way.

We focus exclusively on linear quantum evolution, i.e., quantum state evolution conforming to the principles of QM as discussed for example in Peres (1995), rather than appeal to any form of nonlinear quantum mechanics to generate self-intervention effects. We explore a number of type-three thought experiments involving photons, which act as either quantum or classical objects at various times. As quantum objects they pass through beam-splitters and suffer random outcomes as a result. As classical objects they are used to trigger the switching on or off of macroscopic apparatus, a switching that determines the subsequent quantum evolution of other photons.

We shall not discuss the nature of photons per se, except to say that they are referred to as particles for convenience only: our ideology and formalism treats them as signals in detectors (Jaroszkiewicz, 2008a). Everything is idealized here, it being assumed that all detectors operate with 100 percent efficiency and that photon polarizations and wavelengths can be adjusted wherever necessary to make the scenarios discussed here physically realizable. The experiments we discuss are not necessarily based on photons: other particles such as electrons could be used in principle.

² There is a possible loophole here: our comment involves *two* observers with access to different contextual information. What that means physically is a nontrivial question for any theory of observation. In the absence of any proper theory of such a scenario, we can at best express our opinion on the matter.

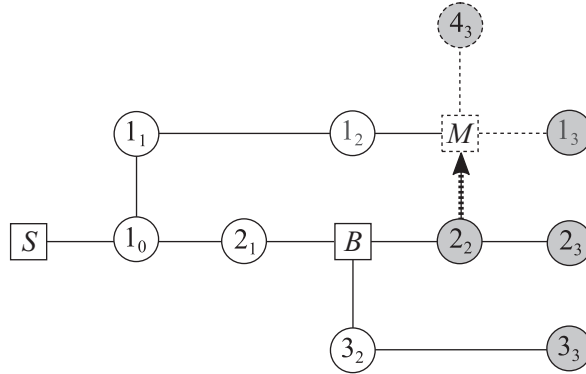

Figure 21.1. If detected, photon 2_2 triggers the switching-on of mirror M that deflects 1_2 into 4_3 rather than 1_3 .

21.2 Experiment SI-1: Basic Self-intervention

To illustrate the sort of experiment we are interested in, we start with the experiment shown schematically in Figure 21.1. By stage Σ_1 , a correlated, non-entangled two-photon state $\Psi_1 \equiv \hat{A}_1^1 \hat{A}_1^2 \mathbf{0}_1$ is created by source S . Channel 2_1 is subsequently passed through beam splitter B into channels 2_2 or 3_2 . If 2_2 is detected physically at stage Σ_2 , then a macroscopic mechanism triggers mirror M to be swung into place so as to deflect 1_2 onto 4_3 rather than 1_3 . The spin of the photons is neglected in this analysis but could easily be included in the discussion and encoded into our computer algebra program MAIN if it were required.

The labstate Ψ_2 at stage Σ_2 is given by

$$\Psi_2 = \hat{A}_2^1 (t \hat{A}_2^2 + ir \hat{A}_2^3) \mathbf{0}_2, \tag{21.1}$$

where t and r are beam splitter B parameters satisfying $t^2 + r^2 = 1$.

Note that in Figure 21.1, detector 2_2 is shown shaded, indicating that the observer looks at it and definitely ascertains its signal status, thereby extracting classical information. If there is no signal there, then the mirror M is not swung into place to intercept the channel from 1_2 , and so a signal is certainly registered in 1_3 . On the other hand, if there is a signal in 2_2 , mirror M swings into place and deflects channel 1_2 into detector 4_3 .

Semi-unitary evolution from stage Σ_2 to stage Σ_3 is given by

$$\mathbb{U}_{3,2} \hat{A}_2^1 \hat{A}_2^2 \mathbf{0}_2 = \hat{A}_3^4 \hat{A}_3^2 \mathbf{0}_3, \quad \mathbb{U}_{3,2} \hat{A}_2^1 \hat{A}_2^3 \mathbf{0}_2 = \hat{A}_3^1 \hat{A}_3^3 \mathbf{0}_3. \tag{21.2}$$

Note that in the program MAIN, null evolution carries 2_2 to 2_3 and 3_2 to 3_3 , and the program reports detector status at stage Σ_3 . The predicted nonzero outcome probabilities are as expected:

$$\Pr(\hat{A}_3^1 \hat{A}_3^3 \mathbf{0}_3 | \Psi_0) = r^2, \quad \Pr(\hat{A}_3^2 \hat{A}_3^2 \mathbf{0}_3 | \Psi_0) = t^2. \tag{21.3}$$

There is nothing unexpected in these results, but there is an unusual confluence of classical and quantum interaction: on the quantum side of the experiment, mirror M is activated in a classically deterministic way only if and when quantum outcome 2_2 occurs, and that is unpredictable.

One interpretation of this experiment is that it is a form of delayed choice experiment: the mirror M is activated only if and when 2_2 has been detected, and this is *after* 1_2 is on its way. The difference between this experiment and previous analysis of delayed choice is that the “choice” is made via quantum processes occurring within the experiment itself, which motivates our chapter title “Self-Intervening Networks.”

21.3 Experiment SI-2: Double Self-intervention

The next variant experiment, SI-2, is shown in Figure 21.2. Source S creates a correlated photon pair $1_1 2_1$ by stage Σ_1 . These are directed into beam splitters B^1 and B^2 as shown. B^2 is used as a trigger. If a signal is detected at 3_2 , that triggers the classical switching-on of beam splitter B^3 , which intercepts 1_2 and channels it into 5_3 or 6_3 instead of it passing on to 1_3 . Conversely, if a signal is observed at 4_2 , beam splitter B^4 is switched on, rather than B^3 . Now 2_2 is channeled by B^4 into 7_3 or 8_3 rather than passing on to 2_3 .

The dynamics is worked out by the methods outlined in previous experiments. The final stage rank is now eight, which presents no problem for program MAIN. Nonzero correlations are found to be

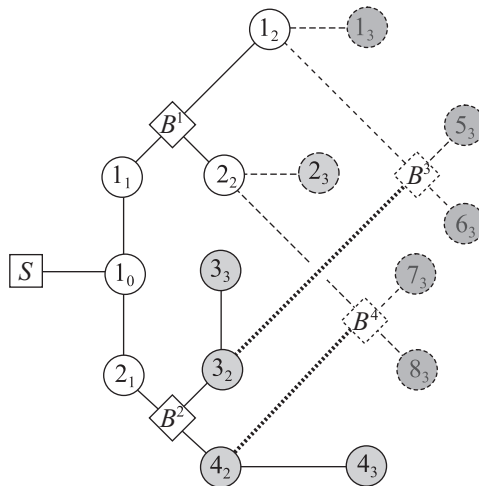

Figure 21.2. Experiment SI-2: in this scheme, no quantum interference occurs, because complete which-path information can be worked out from the signal pattern in each run.

$$\begin{aligned}
 \Pr(\widehat{A}_3^2 \widehat{A}_3^3 \mathbf{0}_3 | \Psi_0) &= (r^1 r^2)^2, & \Pr(\widehat{A}_3^1 \widehat{A}_3^4 \mathbf{0}_3 | \Psi_0) &= (t^1 t^2)^2, \\
 \Pr(\widehat{A}_3^3 \widehat{A}_3^5 \mathbf{0}_3 | \Psi_0) &= (t^1 r^2 r^3)^2, & \Pr(\widehat{A}_3^3 \widehat{A}_3^6 \mathbf{0}_3 | \Psi_0) &= (t^1 r^2 t^3)^2, \\
 \Pr(\widehat{A}_3^4 \widehat{A}_3^7 \mathbf{0}_3 | \Psi_0) &= (r^1 t^2 r^4)^2, & \Pr(\widehat{A}_3^4 \widehat{A}_3^8 \mathbf{0}_3 | \Psi_0) &= (r^1 t^2 t^4)^2.
 \end{aligned}
 \tag{21.4}$$

Individual detector signal probabilities can be worked out from these correlations. For example, $\Pr(1_3)$, the probability that detector 1_3 will be in its signal state rather than its ground state at the final stage Σ_3 , is given by

$$\Pr(1_3) \equiv \Pr(\widehat{A}_3^2 \widehat{A}_3^3 \mathbf{0}_3 | \Psi_0) + \Pr(\widehat{A}_3^3 \widehat{A}_3^5 \mathbf{0}_3 | \Psi_0) + \Pr(\widehat{A}_3^3 \widehat{A}_3^6 \mathbf{0}_3 | \Psi_0) = (r^2)^2, \tag{21.5}$$

and so on.

There are no interference effects predicted in this experiment.

21.4 Experiment SI-3: Interfering Single Self-intervention

The third scenario, SI-3, is shown in Figure 21.3. In this case, the initial photon pair is passed through a pair of beam splitters B^1 and B^2 exactly as in experiment SI-2. The difference lies in the next stage. Channels 1_2 and 2_2 are sent off over sufficiently long optical paths so as to allow interference between channels 3_2 and 4_2 in beam splitter B^3 . If a signal is registered in 4_3 , then beam splitter B^4 is swung into place to intercept 1_3 and 2_3 , so that they can interfere and be observed at 5_4 and 6_4 . If B^4 is not triggered, then 1_3 and 2_3 are channeled on to 1_4 and 2_4 , respectively.

There is a point about beam splitter B^3 that needs attention. This experiment deals with signality-two amplitudes, so there is an issue at beam splitter B^3 in that the possibility exists that a photon comes in from 3_2 and another from 4_2 . This is a case of *beam splitter saturation*, referred to in Chapter 11. Exercise 11.1 shows that if B^3 is *calibrated*, and if the evolution is semi-unitary such that

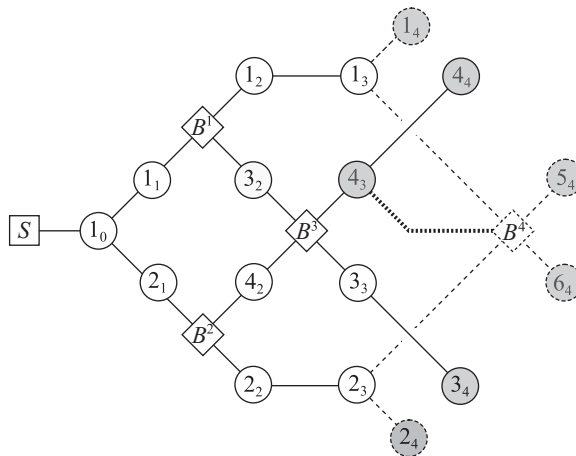

Figure 21.3. Interference at beam splitter B^3 can trigger beam splitter B^4 .

signality one is conserved, then the only scenario permitted is that a signal is detected in 3_4 and in 4_4 . In that case, even though beam splitter B^4 is triggered, no signals are detected at 5_4 or 6_4 .

The beam splitter saturation scenario shows that there is a fundamental difference between *photon self-interference*, which is a signality-one process, and *two-photon scattering*, which is a signality-two process. The former is a manifestation of the quantum superposition principle, whereas the latter depends on the details of photon–matter coupling. For instance, the lowest order amplitude for photon–photon scattering in quantum electrodynamics is proportional to α^2 , where α is the fine structure constant. We mention in passing that the correct calculation of the photon–photon scattering cross section requires delicate treatment of divergent integrals, in order to bring the predictions in line with cosmological observations (Liang and Czarnecki, 2011). This is a good example of the need to factor in detector physics properly in relativistic quantum field theory.

The dynamics for experiment SI-3 is handled in the usual way in program MAIN, with the following predictions:

$$\begin{aligned} \Pr(\widehat{A}_4^1 \widehat{A}_4^2 \mathbf{0}_4 | \Psi_0) &= (t^1 t^2)^2, & \Pr(\widehat{A}_4^1 \widehat{A}_4^3 \mathbf{0}_4 | \Psi_0) &= (t^1 r^2 r^3)^2, \\ \Pr(\widehat{A}_4^4 \widehat{A}_4^5 \mathbf{0}_4 | \Psi_0) &= (t^1 r^2 t^3 r^4 + r^1 t^2 r^3 t^4)^2, & \Pr(\widehat{A}_4^2 \widehat{A}_4^3 \mathbf{0}_4 | \Psi_0) &= (r^1 t^2 t^3)^2, \\ \Pr(\widehat{A}_4^4 \widehat{A}_4^6 \mathbf{0}_4 | \Psi_0) &= (t^1 r^2 t^3 r^4 - r^1 t^2 r^3 t^4)^2, & \Pr(\widehat{A}_4^3 \widehat{A}_4^4 \mathbf{0}_4 | \Psi_0) &= (r^1 r^2)^2. \end{aligned} \tag{21.6}$$

In this variant experiment, two of the outcome correlations, $\Pr(\widehat{A}_4^4 \widehat{A}_4^5 \mathbf{0}_4 | \Psi_0)$ and $\Pr(\widehat{A}_4^4 \widehat{A}_4^6 \mathbf{0}_4 | \Psi_0)$, show interference that has essential contributions from beam splitters B^1 and B^2 in a manner that seems impossible to explain in terms of photons as classical particles.

In all experiments where quantum interference takes place, there inevitably has to be some which-path uncertainty somewhere. This does not occur in variant experiments SI-1 or SI-2 but does occur in SI-3. Program MAIN shows that the interference at 5_4 and 6_4 is photon self-interference and occurs only when a single photon enters B^3 and triggers B^4 . Whenever that happens, the observer cannot say whether it was actually 3_2 or 4_2 that passed into B^3 , and that is the origin of the missing which-path information that is responsible for the interference effect at 5_4 and 6_4 . The signality-two beam splitter saturation possibility triggers B^4 but does not lead to any signals at 5_4 or 6_4 .

Experiment SI-3 involves apparatus change that produces interference and can be identified as doing so: after each run, it will be clear whether B^4 was triggered, and the observer will then be sure that it was that beam splitter that created the interference.

21.5 Schrödinger's Cat

The Schrödinger's cat scenario is a well-known illustration of the dangers of taking a too-literal view of what a quantum wave function represents (Schrödinger,

1935). In brief, the architecture is this. A living cat is placed in a sealed, isolated box along with a flask of poison and a mechanism that contains a radioactive sample. The mechanism will release the poison if it is triggered by the decay of any one of the atoms in the sample. An observer external to the box closes the box and leaves it alone for 1 hour. At that time, the observer opens the box and ascertains whether or not the cat is still alive or now dead.

The issue here is that according to standard quantum wave mechanics, the wave function for the combined system of cat plus radioactive sample will develop from a separable state of a {live cat and undecayed sample} to an entangled superposition of a {live cat and undecayed sample} with a {dead cat and decayed sample}. This prompts questions, such as “How can a cat exist in a superposition of a live state and a dead state?” and so on, which have, over the decades since Schrödinger’s article, generated a plethora of confusing views about the nature of reality.

This scenario is one we can label T3. It is a complex example of a self-intervening network, presented in simple terms.

For us, such questions are vacuous. All of them. If context is taken properly into account, then no such questions need be raised. It suffices to look at what the external observer can do, what they are actually doing, and when they actually do it. The QDN prescription is clear. The observer prepares the combined {cat/box/poison sample} SUO at stage Σ_0 . On the basis of their contextual information, such as the decay probability associated with the radioactive sample, the observer can, just after closing the box, use standard quantum theory to estimate the probability of the cat being alive when the box is opened at stage Σ_1 , that is, 1 hour later. What the observer eventually believes has actually happened inside the box depends on the classical information that is allowed to accumulate there during the hour. For instance, if a decay occurs, not only could it trigger the poison to be released to kill the cat, but the lab time at which this occurred could be registered. When the observer finally opened the box, if they found the cat dead, then the registered time of death would be available.

It is such examples that make it clear that “the” information void is not an absolute concept. It is contextual. In this case, the external observer has no information about what is going on inside the box during the given hour that the experiment runs. Therefore, a quantum description has to suffice. If after opening the box, sufficient classical information is recovered from it to enable the observer to reconstruct events inside that box during that hour, then a rather classical description can be given.

At no point is the observer empirically justified in asserting that the cat is in a quantum superposition of alive and dead. The observer may be justified in imagining a mathematical description of the state of the system in such terms. That is not the same as objective reality.

There are two further points to make here.

A Cat Is a Living Process

It is rather fanciful to think of a cat in terms of a pure quantum state, albeit with a vast number of degrees of freedom. A cat is a living process and therefore not amenable to a reductionist description. In particular, a cat needs an extensive environment to maintain itself: an atmosphere to breathe in, a source of warmth, and so on.

Suppose it was argued that such an environment could be provided inside the box. Yes, but then the observer could not allow that environment to be contaminated by any factors external to the box. What about gravity? What about temperature? What about the expansion of the Universe? Can we really arrange for total shielding of the inside of the box from the outside?

Reductionism in high-energy particle physics seems to work because elementary particle interactions appear to be amenable to shielding during scattering experiments, but even this has been questioned. For instance, it is often imagined that electrons are elementary point particles with a well-identified physical mass in vacuo, represented by a simple pole in their momentum space propagator. But radiative corrections due to “soft” photons (associated with the low-frequency end of the electromagnetic spectrum) appear to turn that pole into a branch cut (in the complex plane), with the consequence that the concept of “electron mass” is problematical. On that basis, an electron cannot be imagined as a single particle, but an extraordinarily complex system of a charge surrounded by an indeterminate cloud of photons.³

Our point is that a highly complex emergent concept such as a living cat might not be amenable to any form of quantum state description, because quantum processes manifest themselves only when phases are carefully controlled. The same comment applies to the so-called quantum mind program of investigation by Hameroff and others, in which brain function is modeled as a form of quantum computation (Hameroff, 1999).

One way of seeing why such a program would not work would be if we described the brain as affected by *contextual overcompleteness*, that is, subject to so many external, extraneous contextual factors that cannot be eliminated, such as temperature variations, pressure fluctuations, and so on, that phase control becomes meaningless and decoherence dominates.

Life and Death Are Not Classic Binary Alternatives

Zero and one (or their equivalents) are regarded as the only two possible alternative states of a classical bit. This degree of simplicity is so powerful and useful that we tend to apply it to many complex situations: we won the war or we

³ It is such considerations that make it obvious to us that elementary particle physics is really a branch of emergent physics and should be approached as such, rather than as a reductionist theory from which emergence could be understood.

lost it; he is a good driver or he is a bad driver; the cat is alive or it is dead. In reality, wars may be lost by both sides, a man may drive well in his village but be reckless on the motorway; a cat may be in a vegetative state that is not dead but is not really worth calling life.

All of these concerns should be addressed before simplistic arguments based on contextually incomplete views of quantum mechanics are given.