

A Structural Model of Goal Orientation in Sports: Personal and Contextual Variables

Francisco Pablo Holgado Tello¹, Leandro Navas Martínez²,
Manuela López Núñez³, and Tomás García Calvo⁴

¹Universidad Nacional de Educación a Distancia (Spain)

²Universidad de Alicante (Spain)

³C.P León Felipe (Spain)

⁴Universidad de Extremadura (Spain)

The following paper first introduces, and then goes on to test a structural model for goal orientation in sports that involves both personal and contextual variables. 511 subjects participated in this study, male and female athletes who play a variety of sports (352 men and 159 women). They ranged in age from 16 to 45-years old and completed the TEOSQ (Balaguer, Tomás & Castillo's version, 1995), the POSQ (Treasure & Roberts, 1994), the PMCSQ-II (Newton & Duda, 1993), the Beliefs about the Causes of Success in Sports Questionnaire, and the Participation Motivation Inventory (Gill, Goss & Huddleston, 1983). The results of this sample show that success attribution and motivational climate are involved in determining goal orientation in sports. However, the model does present certain differences according to the type of sport practiced (individual versus team sport).

Keywords: goal orientation in sports, success attribution, motivational climate, motivation-effort, experience of mastery.

En este artículo se propone y se somete a prueba un modelo causal sobre las orientaciones de meta en el deporte que tiene en cuenta variables contextuales y personales. Participan 511 deportistas procedentes de distintas modalidades deportivas (352 hombres y 159 mujeres). Su rango de edad está comprendido entre los 16 y los 45 años, y han cumplimentado distintas escalas como el TEOSQ (en la versión de Balaguer, Tomás y Castillo, 1995), el POSQ (Treasure & Roberts, 1994), el PMCSQ-II (Newton & Duda, 1993) que miden creencias sobre las causas de éxito deportivo, y el cuestionario de Motivos para la Práctica Deportiva (Gill, Goss y Huddleston, 1983). Los resultados indican que las atribuciones para el éxito y el clima motivacional son determinantes de las orientaciones de meta para el deporte. Sin embargo, el modelo presenta ciertas diferencias de acuerdo con el tipo de deporte practicado (individual-grupal).

Palabras clave: orientaciones de meta en el deporte, atribuciones de éxito, clima motivacional, motivación-esfuerzo, experiencia de maestría.

Correspondence concerning this article should be addressed to Francisco Pablo Holgado Tello. Facultad de Psicología. Departamento de Metodología de las Ciencias del Comportamiento. UNED. C/ Juan del Rosal, 10. 28040 Madrid. (Spain). E-mail: pfolgado@psi.uned.es

Goal orientation theory is among the most widely used in analyzing sports-related variables; it describes two observable orientations: ego and task-involved (Ames, 1992; Duda, 2001; Roberts, 2001). An athlete who has an ego goal orientation compares him or herself to others, seeks to be the best, and strives to win. On the contrary, an athlete who has a task goal orientation compares him or herself to their personal standard or personal best, seeking to persistently improve their achievement and increase their abilities (Cervelló & Santos-Rosa, 2001; Elliot & Conroy, 2005; Roberts, 2001). If one compares this with academic goal orientation, the ego orientation may be viewed as equivalent to the performance goal (Dweck, 1986; Ames, 1984) which, in other studies, is subdivided in two: the achievement goal and the social reinforcement goal (Hayamizu, Ito & Yohiazaki, 1989; Hayamizu & Weiner, 1991). Meanwhile, task goal orientation would be equivalent to the learning goal (Dweck, 1986) or mastery goal (Ames, 1984).

It has been amply demonstrated that goal orientations are related to personal variables including one's reason for playing a sport, success attributions and level of satisfaction with the results (Castillo, Balaguer & Duda, 2000; Cervelló, Escartí & Balagué, 1999), as well as with contextual variables such as the motivational climate created by one's coach and teammates (Flores, Salguero & Márquez, 2008; Papaionnou, Milosis, Kosmidou & Tsigilis, 2007; Sage & Kavussanu, 2008).

Certain research studies have sought to find a relationship between goal orientation and one's reason for playing a sport (Castillo et al., 2000, 2002; Escartí & Gutiérrez, 2001; Sit & Lindner, 2007). The authors of said studies have concluded that ego goal orientation is associated with a desire to achieve success or social status, while task goal orientation is related to motivations such as learning, enjoyment, the development of abilities or being in good physical form.

Other studies have analyzed the relationship between the factors to which success is attributed in sports, and goal orientations (Cervelló et al., 1999; Navas & Soriano, 2006; Veligeekas, Mylonas & Zervas, 2007; White, Kavussanu, Tank & Wingate, 2004). These have shown that ego goal orientation is associated with attributing success to the ability to employ tricks or deception, while task goal orientation is associated with attributing success to effort.

On a related note, upon studying the relationship between goal orientation and satisfaction with the sport one plays, it has been concluded that ego goal orientation is associated with greater boredom, less interest, and satisfaction with having obtained normative success, or in other words, satisfaction with results that demonstrate one is a better athlete than his or her competitors. Task goal orientation, on the other hand, is associated with a greater level of interest, satisfaction with mastery experience and

with greater enjoyment of sports practice (Balaguer, Duda & Crespo, 1999; Castillo et al., 2002; Cervelló et al., 1999).

Carrying on to the contextual variables mentioned above, several research studies have analyzed the relationship between athletes' goal orientations and the motivational climate they perceive from their coaches. From the findings of these studies, it has been concluded that athletes that perceive their coaches to encourage a climate that implicates the ego tend to exhibit more fear of failure, tension and feelings of inadequacy. On the contrary, athletes that perceive the context or the coach to encourage a task-involved climate have more fun and also exert more effort (Baric, 2005; Carr, 2006; Escartí & Gutiérrez, 2001; Flores et al., 2008; García-Calvo, Santos-Rosa, Jiménez & Cervelló, 2006; Kuczka & Treasure, 2005; Reinboth & Duda, 2004; Smith, Balaguer & Duda, 2006).

Considering, as Nicholls (1989) suggested, that dispositional aspects of goal orientation may hold several motivational consequences, it is worth noting that in several of the papers cited above, goal orientation has been the independent variable. Nevertheless, as Ames (1992), Duda (1993), Nicholls (1984, 1989) and Roberts (1992) have posited, goal orientations can emerge from numerous processes of socialization, both in the family and in the classroom, or from participants' previous experiences with physical activity or sports. On this subject, Roberts (2001) states that: "*goal orientations are not to be viewed as "traits". Rather they are considered cognitive schemas*" (p. 17); he goes on to add that "*we learn to be task or ego involved in a particular task*" (p. 18). In other words, goal orientations are schemas that may be applied flexibly and dynamically, depending on the task as well as on the context. Given this contextual sensitivity, goal orientations may be brought on by a given situation or by the motivational climate created by the coach, and by the same token, strategies to promote or prevent goal achievement, too, may come from the context (Crowe & Higgins, 1997; Shah, Higgins & Friedman, 1998). Consider, for example, that if one is ordered to score points or make goals, this is different from the order not to lose points or not to allow the other team to score goals. This may depend on the team's objectives, the opponent's status, what is in the best interest of the club, the type of sport (individual or team), etc. If we take into account that goal orientations may be determined both by dispositional and situational factors (Nicholls, 1984, 1989) and consider Biddle's question (2001): "*Goals or climate: Which comes first?*" (p.120), it is reasonable to assert that goal orientations may emerge either from the subject or from the context. Along that line of thinking, the contribution of the present study lays in trying to find how some of the personal and contextual variables at work explain goal orientations in sports and whether the type of sport, individual versus team, may bring about any differences.

Upon continuing to analyze the body of work that considers both dispositional and situational goals, Duda & Nicholls (1992) suggested that selecting the most appropriate independent variable depends on the variable being predicted. As such, if the dependent variable were to resemble a particular characteristic, and to be specific to a given situation, the perceived motivational climate would prove to be the most important. Similarly, if the dependent variable is dispositional (e.g., beliefs about the causes of success in sports, in a broad sense), goal orientation would be the most suitable independent variable. Based on this notion, the idea has been defended (Duda & Hall, 2001) that goal orientations and perceived goals in a particular situation may interact. It must also be taken into account that ego goal orientation is correlated with a lower level of achievement, less intrinsic motivation and is less adaptive, while task goal orientation is associated with greater achievement and higher intrinsic motivation, while also being more adaptive (Castillo et al., 2002; Cervelló et al., 1999; Smith et al., 2006). It is for those reasons that there is interest in analyzing the variables that predict goal orientations. With these things in mind, the objective of the present study is to analyze the influence of type of sport (individual or team), personal variables such as perception of success (experience of mastery, social approval and normative success), one's beliefs about attaining success in sports (motivation-effort, normative ability and deception techniques), one's reasons for playing sports in the first place (energy release, fulfillment, being in good physical form, practicing as a group, developing abilities, social factors, recreation-seeking and fun) and contextual variables (ego versus task-involved climate) in predicting dispositional goal orientations (ego or task).

Methods

Participants

511 federated athletes participated in the study, 352 men and 159 women ranging in age from 16 to 45 years-old, with an average age of 22.87 years ($\sigma = 5.24$) who play a range of different sports (Tennis, 23.7%; Handball, 13.1%; Football, 11.7%; Indoor Soccer, 8.4%; Karate, 7.6%; Basketball, 6.7%; Track and Field, 6.1%; Volleyball, 5.5%; Taekwondo, 4.5%; Cycling, 3.5%; Rugby, 2.2%; Rhythmic Gymnastics, Swimming and Water Polo, 1.4%; Climbing, 1%; Judo, .6%, Kite surfing, Equestrian and Archery, .4%; and Baseball, .2%). 50.3% of participants play individual sports and 49.7% play team sports. They were selected through a convenience sampling (40.5% are from Elche, 36% from Alicante, 9.8% from Murcia, 3.9% from Valencia and the remaining 9.8% were from other Spanish cities – Sevilla, A Coruña, Palma de Mallorca, Madrid, Castellón, etc.).

Variables and Instruments

All instruments employed, which will be described later in this paper, were found to be sufficiently reliable and valid in previous studies conducted in this field (Balaguer, Guivernau, Duda & Crespo, 1997; Balaguer, Tomás & Castillo, 1995; Cervelló et al., 1999; López & Márquez, 2000; López, 2008).

The variables under consideration follow; the questionnaire used to evaluate each variable is also indicated.

Independent Variables:

1. Satisfaction with the results of playing sports: experience of mastery (EM), social approval (SA) and normative success (NS). These were evaluated by Treasure & Roberts' (1994) *POSQ* (Perception of Success Questionnaire); a version in Spanish by Cervelló et al. (1999) was used (the *CSRD*). This measure includes 10 items that follow a Likert-type scale ranging from 1 (strongly disagree) to 5 (strongly agree), and it is comprised of 3 subscales: mastery experience (items 1, 2, 3, 4 and 5), which describes a subject's preference for results that reflect personal progress; social approval (items 9 and 10), which is the desire to achieve social recognition, and normative success (items 6, 7 and 8), which describes the preference for results that demonstrate that one is a more capable athlete than his or her competitors. The internal consistency for each subscale was .72, .87 and .58, respectively (Cervelló et al., 1999) and .77, .70 and .69, respectively (López, 2008).
2. Perceived motivational climate: task-involved climate (TIC) and ego-involved climate (EIC) were evaluated by Newton & Duda's (1993) *PMCSQ-II* (Perceived Motivational Climate in Sports Questionnaire – II). This instrument consists of 29 items and is composed of two subscales. The first (with 15 items) reflects the perception of a task-oriented climate and the second (with 14 items) represents the perception of an ego-oriented climate. The internal consistency for the two subscales is .84 and .85, respectively (López, 2008). The response scale is a 5-point Likert scale (1 meaning "strongly disagree" and 5 signifying "strongly agree").
3. Beliefs about attaining success in sports: motivation-effort (ME), normative ability (NA) and deception techniques (DT) were all evaluated using Duda and Nicholls' (1992) Beliefs about the Causes of Success in Sports Questionnaire (the Spanish language version is called the *CCCED*). It is comprised of 14 items in which 3 factors are embedded. The motivation-effort factor,

consisting of 6 items, refers to the attribution of success to the effort exerted while performing a task. The normative ability factor is made up of 4 items and refers to attributing success to ability. Last, the deception factor, also consisting of 4 items, represents the attribution of success to deceptive behaviors such as, for example, creating traps. The reliability of these factors is .78, .62 and .72, respectively (Cervelló et al., 1999), and .81, .84 and .76 (López, 2008). The response scale used was a 5-point Likert scale (1 meaning “strongly disagree” and 5 signifying “strongly agree”).

4. Reasons for playing sports: energy release or personal satisfaction (PS), status or fulfillment motive (ST), to be in good physical form (PF), group practice (GP), developing abilities (DA), social factors (SF), recreation-seeking (RS) and fun-seeking (FS). These were evaluated with the *Participation Motivation Inventory* by Gill, Gross & Huddleston (1983); a version by López & Márquez (2000) was employed. It consisted of 30 items and 8 factors corresponding to one's reasons for playing sports; they are mentioned above: PS (5 items), ST (5 items), PF (3 items), GP (3 items), DA (5 items), SF (3 items), RS (4 items) and FS (2 items). The α coefficient for the scale as a whole is .84. A 3-point response scale was utilized (1 being “not important” and 3 being “very important”).

Dependent Variables:

1. Goal orientations (ego and task-involved) were evaluated by the Spanish language version (Balaguer et al. 1995) of the *TEOSQ* (Task and Ego Orientation in Sports Questionnaire). It has 13 items that are assessed on a 5-point scale and responses range from strongly disagreeing to strongly agreeing. 7 items reflect a task-involved orientation and 6 evaluate the ego-involved orientation. The instrument has an internal consistency, a *Cronbach's alpha coefficient*, of .84 and .87 in each of the subscales.

Procedure, Research Design and Data Analysis

The data were collected between October, 2006 and February, 2007. In order to administer the questionnaires, and to agree upon a day to do so, the collaboration of coaches and clubs was sought. During the training session or practice that had been previously agreed upon, the objectives of the study were explained to the athletes and they were encouraged to, voluntarily and anonymously, respond individually to the questionnaires.

The research design was *ex post facto* and used basic correlation analysis, given that subjects were not

randomly selected and the variables were not intentionally manipulated (León & Montero, 1998). The data were subjected to multiple regression and correlation analyses, using the SPSS statistical software package (version 16.0), and structural analyses via *path analysis*. Next, the data was analyzed using maximum likelihood estimation by employing the LISREL program (version 8.71). Additionally, a multi-group analysis was performed as a function of the type of sport (individual or team).

Results

Multiple linear regression analyses (enter) were performed in order to establish a simple, predictive model of goal orientations. The independent variables were considered to be those that involve one's perception of success in sports (EM, SA and NS), the motivational climate (TIC and EIC), one's beliefs about attaining success in sports (ME, DT and NA) and one's reasons for playing sports (PS, ST, PF, GP, DA, SF, RS and FS).

The results of the regression analyses performed are summarized in Table 1. For task goal orientation, the variables that enter into the equation, with statistically significant *t* values ($p \leq .042$), were experience of mastery (EM), task-involved climate (TIC), ego-involved climate (EIC), motivation-effort (ME), normative ability (NA), social factors (SF), recreation-seeking (RS) and fun-seeking (FS). These variables explained 44% of the variance ($R^2 = .439$). For ego goal orientation, on the other hand, the relevant variables, with statistically significant *t* values ($p \leq .037$), were normative success (NS), ego-involved climate (EIC), motivation-effort (ME), deception techniques (DT), normative ability (NA), status or fulfillment motive (ST), group practice (GP), and social factors (SF). These accounted for 31.4% of the variance ($R^2 = .314$).

These results, together with the analyses of correlation and revising the research question, enable us to propose a compound structural model for the variables being studied. The findings have been interpreted from the perspective of statistical control, not from a determinist perspective (Bollen, 1989). In the model, the independent variables include experience of mastery (EM), normative success (NS), task-involved climate (TIC), ego-involved climate (EIC), motivation-effort (ME), normative ability (NA), deception techniques (DT), status motivation (ST), group practice (GP), social factors (SF), fun-seeking (FS) and recreation-seeking (RS), while the dependent variables are goal orientations.

By solving various systems of structural equations, some independent variables were eliminated from the initial model (ST, GP, SF and FS), either because they did not allow for the model to have a reasonable degree of fit, or because they lacked sufficient explanatory power. Table

Table 1

Multiple regression analysis to establish predictive models of goal orientations (EGO and TASK)

Dependent variables	Ind. Variables	<i>t</i>	<i>p</i>	β
Task goal orientation (TASK) <i>R</i> ² = .439 <i>E.E.</i> <i>R</i> ² = .421	EM	5.219	.000*	.235
	SA	-1.364	.173	-.053
	NS	-1.339	.181	-.060
	TIC	8.574	.000*	.346
	EIC	2.090	.037*	.084
	ME	4.244	.000*	.200
	DT	.272	.786	.012
	NA	-2.043	.042*	-.094
	PS	1.411	.159	.062
	ST	-.997	.319	-.044
	PF	1.638	.102	.067
	GP	-.725	.469	-.027
	DA	1.561	.119	.060
	SF	2.874	.004*	.116
RS	2.281	.023	.110	
FS	-2.876	.004*	-.145	
Ego goal orientation (EGO) <i>R</i> ² = .314 <i>E.E.</i> <i>R</i> ² = .292	EM	1.510	.132	.075
	SA	-1.899	.058	-.081
	NS	3.764	.000*	.186
	TIC	-.211	.833	-.009
	EIC	3.951	.000*	.176
	ME	-3.828	.000*	-.199
	DT	2.087	.037*	.100
	NA	3.411	.001*	.173
	PS	-.661	.509	-.032
	ST	3.673	.000*	.179
	PF	1.455	.146	.066
	GP	-3.188	.002*	-.131
	DA	-.132	.895	-.006
	SF	-2.244	.025*	-.100
RS	.242	.809	.013	
FS	-.924	.356	-.052	

Note . * 95% significance (EM= Experience of mastery; SA= Social approval; NS= Normative success; TIC= Task-involved climate; EIC= Ego-involved climate; ME= Motivation-effort; NA= Normative ability; DT= Deception techniques; PS= Energy release or Personal satisfaction; ST= Status or Fulfillment motive; PF= Physical form; GP= Group practice; DA= Developing abilities; SF= Social factors; RS= Recreation-seeking; FS= Fun-seeking).

2 displays the matrix of correlations between the remaining variables in the model. Clearly, the values for Pearson’s correlation coefficients are less than .85, which may indicate the absence of multi-colinearity (Kline, 1998).

Figure 1 depicts the completely standardized solution obtained by applying the proposed model. The model finds a *Chi-square* value equaling 15.04 (*df* = 35; *p* = .97) and adequate global indices of goodness of fit (*RMSEA* = .00; *GFI* = .99; *AGFI* = .99), which indicates that it represents rather well the relationships between the variables.

Once it was confirmed that the model obtained fit reasonably well with the variables being studied, the invariance was evaluated as a function of the type of sport played (individual or team). To put it another way, we tried

to determine whether or not the model being analyzed was equally fitting for individual sport athletes and team sport athletes. In order to do so, we first evaluated the equivalence of structure and next, invariance in the pattern of gamma parameters.

Hypothesis 1: Equivalence of structure of the model being analyzed

First, all parameters were estimated at once through a multi-group analysis without imposing any restriction as far as the invariance of the gamma coefficients that relate the independent and the dependent variables (EGO and TASK). The purpose of these analyses was to

Table 2

Matrix of correlations between the model's variables

	EM	TIC	EIC	ME	RS	NS	NA	EGO	TASK
EM	-	.413**	-.071	.588**	.184**	.320**	.139**	-.009	.502**
TIC	-	-	-.249**	.456**	.122**	.185**	.041	-.130**	.519**
EIC	-	-	-	-.145**	.130**	.203**	.301**	.378**	-.081
ME	-	-	-	-	.186**	.311**	.207**	-.142**	.489**
RS	-	-	-	-	-	.206**	.201**	-.053	.243**
NS	-	-	-	-	-	-	.206**	.290**	.156**
NA	-	-	-	-	-	-	-	.365**	.009
EGO	-	-	-	-	-	-	-	-	-.070
TASK	-	-	-	-	-	-	-	-	-

Note. * $p < .05$; ** $p < .01$ (EM= Experience of mastery; TIC= Task-involved climate; EIC= Ego-involved climate; ME= Motivation-effort; RS= Recreation-seeking; NS= Normative success; NA= Normative ability; EGO= Ego goal orientation; TASK= Task goal orientation).

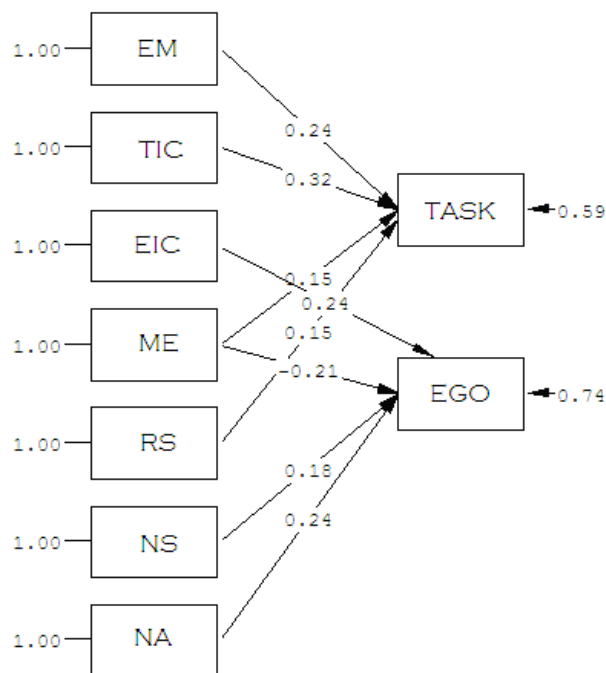

Figure 1. Diagram of goal orientation pathways (EGO and TASK) EM: Experience of mastery; TIC: Task-involved climate; EIC: Ego-involved climate; ME: Motivation-effort; RS: Recreation-seeking; NS: Normative success; NA: Normative ability; TASK: Task goal orientation; EGO: Ego goal orientation.

obtain empirical evidence about the validity of the model represented graphically in Figure 1. The correlations established between goal orientations (ego-involved and task-involved) and certain variables were analyzed: mastery experience (EM), task-involved climate (TIC), motivation-effort (ME), ego-involved climate (EIC), normative success (NS), recreation-seeking (RS) and

normative ability (NA), to see if they fit equally well for individual sports and team sports.

The results obtained are displayed in the first row of Table 3 (comparison model, Model 1).

The indices for goodness of fit, taking into consideration both sport modalities (Model 1), were $\chi^2 = 27.30$ ($df = 70$; $p = 1.00$), $ECVI = .11$, $RMSEA = .00$, $GFI = .99$ and $CFI = 1.00$. Given these findings, we can accept the hypothesis that the model for Goal Orientations (ego and task) does not vary as a function of type of sport being played (individual vs. team sport). Despite the fact that in both groups, the same variables play an important role, there does not necessarily exist a common pattern of gamma coefficients, which may have an impact on the relationships between independent and dependent variables. Thus, it becomes necessary to examine whether or not those coefficients are the same for both groups.

Hypothesis II: Invariance of the gamma coefficients

To test this hypothesis, equality restrictions were applied to each γ . First of all, the results depart from the null hypothesis which states that all the coefficients are equal for the two groups (Table 3, Model 2). Next, if there were significant differences from the comparison model (Model 1), the equivalence of the coefficients corresponding to each variable and to each type of sport was tested.

The results found in Table 3 show that the null hypothesis of equality must be rejected because there is a significant increase in χ^2 from the baseline in Model 1 ($\Delta\chi^2 = 334$; $\Delta df = 8$) (Model 2). For that reason, although the proposed model could be considered equivalent for the two groups on a certain level, there are differences in our understanding of the relationships between the two sport modalities. Thus, which variable is differentially understood must be tested, variable by variable.

Table 3

Summary of the analysis of invariance for the model obtained

Groups as a function of type of sport						
Model	$\chi^2(\Delta\chi^2)$	$df(\Delta df)$	<i>ECVI</i>	<i>RMSEA</i>	<i>GFI</i>	<i>CFI</i>
Hypothesis I: (model 1)	27.30	70	.11	.00	.99	1.00
Hypothesis II:(model 2)	(420.5)*	(8)	.48	.10	.84	.84
TASK						
Gamma EM on task	(29.12)*	(1)	.11	.00	.98	1.00
Gamma TIC on task	(57.39)*	(1)	.12	.02	.97	.00
Gamma ME on task	(10.78)*	(1)	.11	.00	.99	1.00
Gamma RS on task	(16.69)*	(1)	.11	.00	.99	1.00
EGO						
Gamma EIC on ego	(24.88)*	(1)	.11	.00	.98	1.00
Gamma ME on ego	(0.03)	(1)	.11	.00	.99	1.00
Gamma NS on ego	(57.52)*	(1)	.12	.02	.97	.99
Gamma NA on ego	(58.42)*	(1)	.12	.02	.97	.99

Invariance of the measurement model (Model 2); * $p < .05$. $\Delta\chi^2$ (increase in χ^2 with respect to Model 1, or comparison model) and Δdf (change in degrees of freedom).

Table 3 also shows that the increase in *Chi-square* with respect to the comparison model of gamma coefficients was statistically significant for the variables corresponding to Task Goal Orientation: experience of mastery (EM), task-involved climate (TIC), recreation-seeking (RS) and motivation-effort (ME). This indicates that its parameters vary for individual and team sports. The same may be said of the variables ego-involved climate (EIC), normative success (NS) and normative ability (NA), which correspond to an Ego Goal Orientation. Nevertheless, we cannot say the same for the coefficient of the motivation-effort variable (ME), also corresponding to the Ego Goal Orientation, because it did not vary for the two sport modalities. In other words, motivation-effort is interpreted the same way for athletes that play individual sports as those who play team sports.

Discussion

To begin with, the results of the regression analysis indicate that the variables normative success, ego-involved climate, motivation-effort, deception techniques, normative ability, status motivation, group practice and social factors contributed to explaining ego goal orientation, which is consistent with the findings of other studies (White et al., 2004, for example). By the same token, the variables mastery experience, task-involved climate, ego-involved climate, motivation-effort, normative ability, social factors and fun played a role in explaining task goal orientation. With the exception of ego-involved climate, these results agree with the findings of other studies (Reinboth & Duda, 2004, for example),

but in the reverse direction of the variables: when goal orientations were considered as the predictors.

Secondly, with the aforementioned results in mind, and with the objective of analyzing the influence of personal variables (reasons for playing sports, success attributions and satisfaction with the results), as well as contextual variables (motivational climate), on athletes' goal orientations, a structural model may be proposed and its fit may be measured by resolving models of structural equations. In this type of analysis, the objective is to determine if the researcher's inferences are consistent with the data gathered and, consequently, the only conclusion that can be reached, in this case, is that the model is upheld and not rejected. That is to say, this certainly does not imply that other models could achieve a good fit with the data, too (Bollen, 1989). In light of all of these findings, and the completely standardized solution reached, some conclusions have arisen that may be of interest. The correlation found between mastery experience and task goal orientation, for example, indicates that as an athlete's mastery experience increases, so does task goal orientation. This supports the idea that task goal oriented athletes feel satisfied by mastery experience and learning (Noutmanis & Biddle, 1999) and suggests that mastery experience may bring about task goal orientation. Furthermore, the positive correlation observed between motivation-effort and task goal orientation indicates that attributing success to effort orients the athlete toward wanting to learn and improve (characteristics of task goal orientation). Meanwhile, the negative correlation between motivation-effort and ego goal orientations elucidates the fact that the more success is attributed to effort, the less important it is

to stand out amongst the others, or to compete with them (characteristics of ego goal orientation), which confirms the findings of prior research (Cervelló & Santos-Rosa, 2001). Additionally, the positive correlation between normative ability and ego goal orientation may suggest that attributing success to possessing greater ability generates a desire to defeat others and stand out among them. All of the above confirms that athletes' success attributions have much to do with goal orientation (Cervelló, Calvo, Ureña, Martínez & Guzmán, 2006; Cervelló et al., 1999). Nevertheless, the results could also be interpreted as a function of subjects' beliefs about their own ability, as being stable versus dynamic (something that can improve) (Dweck, 1999, 2002). This notion could be the basis of future research studies in this field. On another note, it may also be deduced that the perceived motivational climate plays an important role in determining athletes' goal orientations in that the results indicate task-involved climate is positively correlated with task goal orientation, and ego-involved climate is positively correlated with ego goal orientation, as other studies have demonstrated (Carr, 2006; Escartí & Gutiérrez, 2001; Flores et al., 2008; García-Calvo et al., 2006; Papaioannou et al., 2007; Sage & Kavussanu, 2008; Smith et al., 2006). Finally, the results indicate that satisfaction with sports due to having a greater ability than the others (normative success) predicts ego goal orientation and that when one's reasons for playing sports are action-oriented or challenge-oriented (recreation-seeking), this predicts task goal orientation, which corroborates the findings of other studies conducted in this area (Balaguer et al., 1997; Castillo et al., 2002; Cervelló et al., 1999). Perhaps it would be privy to conduct longitudinal studies in order to better determine whether goal orientation truly plays the role of the independent or dependent variable.

Next, the invariance of the model was evaluated as a function of the type of sport played: individual or team. In this case, the results gathered allow us to conclude that, although the predictive model of goal orientations did not vary according to type of sport (individual or team), there were variations in the way in which variables were related to one another, excluding the relationship between motivation-effort and ego goal orientation (that correlation was stable for both the individual and team sport modalities). This last thought indicates that attributing success in sports to the effort exerted in order to complete a given task generates very little ego goal orientation in both types of sports practice, which is reasonable considering that attributing success to having more ability than others predicts a high level of ego goal orientation (Castillo et al., 2002; Cervelló et al., 1999) and is negatively correlated with task goal orientation. In addition, the finding that correlations between the rest of the variables and goal orientations vary as a function of

the type of sport being played may indicate that athletes' perceptions of the success, cooperation and competition required by a given task or by one's personal ability differs for individual and team sports. One practical implication of this is to emphasize, as a function of the type of sport, some perceptions over others during athletic training. It is important to note that it is crucial to develop ideas, beliefs and abilities in athletes that allow them to endure the demands and pressures of competition (Buceta, 1996) and that task goal orientation, as it is more adaptive and maintains an athlete's motivation longer, is associated with greater achievement (García-Calvo et al., 2008; Roberts, 2001). Another practical implication of these findings is that, in light of the influence of success attributions and motivational climate over goal orientations, coaches should instill in athletes the idea that success is attributed to effort and work more than sheer ability, and to propose achievement objectives such as personal improvement and mastering one's abilities instead of objectives such as beating the others. A further practical application of these results is that coaches, who are responsible for managing the perceived motivational climate, motivation-effort and normative abilities of athletes, can generate one goal orientation or another in them and, as has been suggested earlier, task orientation is more adaptive, because through failure, athletes learn to be more persistent and to increase their effort. The climate encouraged should be task-oriented, with the objective of making sports practice more satisfying and raising achievement.

From a theoretical perspective, these results corroborate, first, that goal orientation, in addition to expressing a criterion from which to evaluate athletic success or failure (Nicholls, 1989), is related to what athletes think, feel and perceive and, second, these relationships may explain or predict athletes' goal orientations (ego or task-involved). It stands out especially that, with the exception of motivation-effort, the relationships between variables differ according to whether the sport is an individual or team sport, a finding which illuminates the perspective that those differences must be taken into account.

Nevertheless, these conclusions should be considered with an awareness of the restrictions imposed by the sampling method employed and of the data collection techniques since subjects, upon responding, could have incurred ego-defensive or social desirability biases.

References

- Ames, C. (1984). Competitive, cooperative, and individualistic goal structures: A motivational analysis. En R. Ames & C. Ames (Eds.), *Research on motivation in education: Students motivation* (pp. 177-207). Nueva York: Academic Press.
- Ames, C. (1992). Achievement goals, motivational climate, and motivational processes. En G. C. Roberts (Ed.), *Motivation*

- in sport and exercise* (pp. 161-176). Champaign, IL: Human Kinetics.
- Balaguer, I., Duda, J. L., & Crespo, M. (1999). Motivational climate and goal orientations as predictors of perceptions of improvement, satisfaction and coach ratings among tennis players. *Scandinavian Journal of Medicine and Science in Sport*, 9, 381-388.
- Balaguer, I., Guivernau, M., Duda, J. L., & Crespo, M. (1997). Análisis de la validez de constructo y de la validez predictiva del Cuestionario de Clima Motivacional Percibido en el Deporte (PMCSQ-2) con tenistas españoles de competición. *Revista de Psicología del Deporte*, 11, 41-57.
- Balaguer, I., Tomás, I., & Castillo, I. (1995). Orientación al ego y a la tarea en el deporte (TEOSQ): Propiedades psicométricas y análisis factorial de la traducción castellana. *V Congreso Nacional de Psicología de la Actividad Física y el Deporte*. 22 a 24 de marzo. Valencia.
- Biddle, S. J. H. (2001). Enhancing motivation in physical education. En G. C. Roberts (Ed.), *Advances in motivation in sport and exercise* (pp. 51-78). Champaign, IL: Human Kinetics.
- Bollen, K. (1989). *Structural Equations with Latent Variables*. Nueva York: John Wiley.
- Buceta, J. M. (1996). *Psicología y lesiones deportivas: prevención y recuperación*. Madrid: Dykinson.
- Carr, S. (2006). An examination of multiple goals in children's physical education: Motivational effects of goal profiles and the role of perceived climate in multiple goal development. *Journal of Sport Sciences*, 24(3), 281-297.
- Castillo, I., Balaguer, I., & Duda, J. L. (2000). Las orientaciones de meta y los motivos de práctica deportiva en los jóvenes deportistas valencianos escolarizados. *Revista de Psicología del Deporte*, 9(1), 37-50.
- Castillo, I., Balaguer, I., & Duda, J. L. (2002). Goals perspectives of adolescents in sport context. *Psicothema*, 14(2), 280-287.
- Cervelló, E., Calvo, R., Ureña, A., Martínez, M., & Guzmán, J. (2006). Situational and dispositional predictors of task involvement in Spanish professional female volleyball players. *Journal of Human Movement Studies*, 50(1), 47-63.
- Cervelló, E., Escartí, A., & Balagué, G. (1999). Relaciones entre la orientación de meta disposicional y la satisfacción con los resultados deportivos, las creencias sobre las causas de éxito en deporte y la diversión con la práctica deportiva. *Revista de Psicología del Deporte*, 8(1), 7-19.
- Cervelló, E., & Santos-Rosa, F. J. (2001). Motivation in Sport: An achievement goal perspective in Spanish recreational athletes. *Perceptual and Motor Skills*, 92, 527-534.
- Crowe, E., & Higgins, E. T. (1997). Regulatory focus and strategic inclinations: Promotion and prevention in decision-making. *Organizational Behavior and Human Decision Processes*, 69(2), 117-132.
- Duda, J. L. (2001). Goals perspectives research in sport: pushing the boundaries and clarifying some misunderstandings. En G. C. Roberts (Ed.), *Advances in motivation in sport and exercise* (pp. 129-182). Champaign, IL: Human Kinetics.
- Duda, J. L., & Balaguer, I. (1999). Toward an integration of models of leadership with a contemporary theory of motivation. En R. Lidor & M. Mar-Eli (Eds.), *Linking theory and practice* (pp. 213-230). Morgantown, WV: Fitness Information Technology.
- Duda, J. L., & Hall, H. (2001). Achievement goal theory in sport. En R. N. Singer, H. A. Hausenblas & C. M. Janelle (Eds.), *Handbook of sport psychology* (pp. 417-443). Nueva York: Wiley.
- Duda, J. L., & Nicholls, J. G. (1992). Dimensions of achievement motivation in school-work and sport. *Journal of Educational Psychology*, 84(3), 290-299.
- Dweck, C. S. (1986). Motivational processes affecting learning. *American Psychologist*, 41, 1040-1048.
- Dweck, C. S. (1999). *Self-Theories: Their Role in Motivation, Personality, and Development*. Philadelphia, PA: Taylor & Francis.
- Dweck, C. S. (2002). The development of ability conceptions. En A. Wigfield & J. S. Eccles (Eds.), *Development of achievement motivation* (pp. 57-88). Nueva York: Academic Press.
- Elliot, A. J., & Conroy, D. E. (2005). Beyond the dichotomous model of achievement goals in sport and exercise psychology. *Sport and Exercise Psychology Review*, 1, 17-25.
- Escartí, A., & Gutiérrez, M. (2001). Influence of the Motivational Climate in Physical Education on the intention to practice physical activity of Sport. *European Journal of Sport Science*, 1, 4
- Flores, J., Salguero, A., & Márquez, S. (2008). Goal orientations and perceptions of the motivational climate in physical education classes among Colombian students. *Teaching and Teacher Education*, 24(6), 1441-1449.
- García-Calvo, T., Leo, F. M., Martín, E., & Sánchez, P. A. (2008). El compromiso deportivo y su relación con factores disposicionales y situacionales contextuales de la motivación. *Revista Internacional de Ciencias del Deporte*, 12(4), 45-58.
- García-Calvo, T., Santos-Rosa, F. J., Jiménez, R. C., & Cervelló, E. (2006). El clima motivacional en las clases de Educación Física: una aproximación práctica desde la Teoría de Metas de Logro. *Apuntes: Educación Física y Deportes*, 81, 21-28.
- Gill, D. L., Gross, J. B., & Huddleston, S. (1983). Participation motivation in youth sports. *International Journal of Sport Psychology*, 14, 1-14.
- Hayamizu, T., Ito, A., & Yohiazaki, K. (1989). Cognitive motivational process mediated by achievement goal tendencies. *Japanese Research*, 31, 179-189.
- Hayamizu, T., & Weiner, B. (1991). A test of Dweck's model of achievement goals are related to perceptions of ability. *Journal of Experimental Education*, 59, 226-234.
- Kline, R. (1998). *Principles and practice of Structural Equation Modeling*. The Guilford Press: Londres.
- Kuczka, K., & Treasure, D. (2005). Self-handicapping in competitive sport: Influence of the motivational climate, self-efficacy, and perceived importance. *Psychology of Sport and Exercise*, 6(5), 539-550.

- León, O., & Montero, N. (1998). *Diseños de investigación*. Madrid: McGraw-Hill.
- López, M. (2008). *Un modelo causal de las orientaciones de meta en el ámbito deportivo: deportes individuales y en equipo*. Tesis Doctoral no publicada, Facultad de Educación, Universidad de Alicante.
- López, C., & Márquez, S. (2000). Motivación en jóvenes practicantes de lucha leonesa. *Revista de Psicología del Deporte*, 10(1), 9-22.
- Navas, L., & Soriano, J. A. (2006). Metas, atribuciones y sus relaciones en las clases de Educación Física. *Infancia y Aprendizaje*, 29(4), 411-421.
- Newton, M., & Duda, J. L. (1993). The Perceived Motivational Climate in Sport Questionnaire: Construct and Predictive Utility. *Journal of Sport and Exercise Psychology*, 15, 437-448.
- Nicholls, J. G. (1984). Conceptions of ability and achievement motivation. En R. Ames & C. Ames (Eds.), *Research on motivation in education: Student motivation* (pp. 39-73). Nueva York: Academic Press.
- Nicholls, J. G. (1989). *The competitive ethos and democratic education*. Cambridge, MA: Harvard University Press.
- Noutmanis, N., & Biddle, S. (1999). Affect and achievement goals in physical activity: A meta-analysis. *Scandinavian Journal of Medicine and Science in Sports*, 9, 315-332.
- Papaioannou, A. G., Milosis, D., Kosmidou, E., & Tsigilis, N. (2007). Motivational climate and achievement goals at the situational level of generality. *Journal of Applied Sport Psychology*, 19, 38-66.
- Pintrich, P. R., & Schunk, D. H. (2006). *Motivación en contextos educativos. Teoría, investigación y aplicaciones*. Madrid: Pearson Educación.
- Reinboth, M., & Duda, J. (2004). The motivational climate, perceived ability and athletes psychological and physical well-being. *Sport Psychologist*, 18(3), 237-251.
- Roberts, G. C. (1992). *Motivation in sport and exercise*. Champaign, IL: Human Kinetics.
- Roberts, G. C. (2001). Understanding the dynamics of motivation in physical activity: The influence of achievement goals on motivational processes. En G. C. Roberts (Ed.), *Advances in motivation in sport and exercise* (pp. 1-50). Champaign, IL: Human Kinetics.
- Sage, L., & Kavussanu, M. (2008). An exploration of temporal stability and reciprocal relationships between goal orientations, motivational climate and prosocial and antisocial behaviour in youth soccer. *Journal of Sport Sciences*, 26, 717-732.
- Shah, J., Higgins, E. T., & Friedman, R. S. (1998). Performance incentives and means: How regulatory focus influences goal attainment. *Journal of Personality and Social Psychology*, 47(2), 285-393.
- Sit, C. H. P., & Lindner, K. J. (2007). Achievement goal profiles, perceived ability and participation motivation for sport and physical activity. *International Journal of Sport Psychology*, 38(3), 283-303.
- Smith, A., Balaguer, I., & Duda, J. L. (2006). Goal orientation profile differences on perceived motivational climate, perceived peer relationships, and motivation-related responses of youth athletes. *Journal of Sports Sciences*, 24(12), 1315-1327.
- Treasure, D. C., & Roberts, G. C. (1994). Perception of Success Questionnaire: Preliminary validation in an adolescent population. *Perceptual and Motor Skills*, 79, 607-610.
- Veligeas, P., Mylonas, K., & Zervas, Y. (2007). Goal orientation and beliefs about the causes of success among greek track and field athletes. *Perceptual and Motor Skills*, 105(3), 927-938.
- White, S., Kavussanu, M., Tank, K., & Wingate, J. (2004). Perceived parental beliefs about the causes of success in sport: Relationship to athletes' achievement goals and personal beliefs. *Scandinavian Journal of Medicine and Science in Sports*, 14(1), 57-66.

Received November 25, 2008

Revision received September 07, 2009

Accepted September 21, 2009